

Operating Manual

G3 Digital Cutter

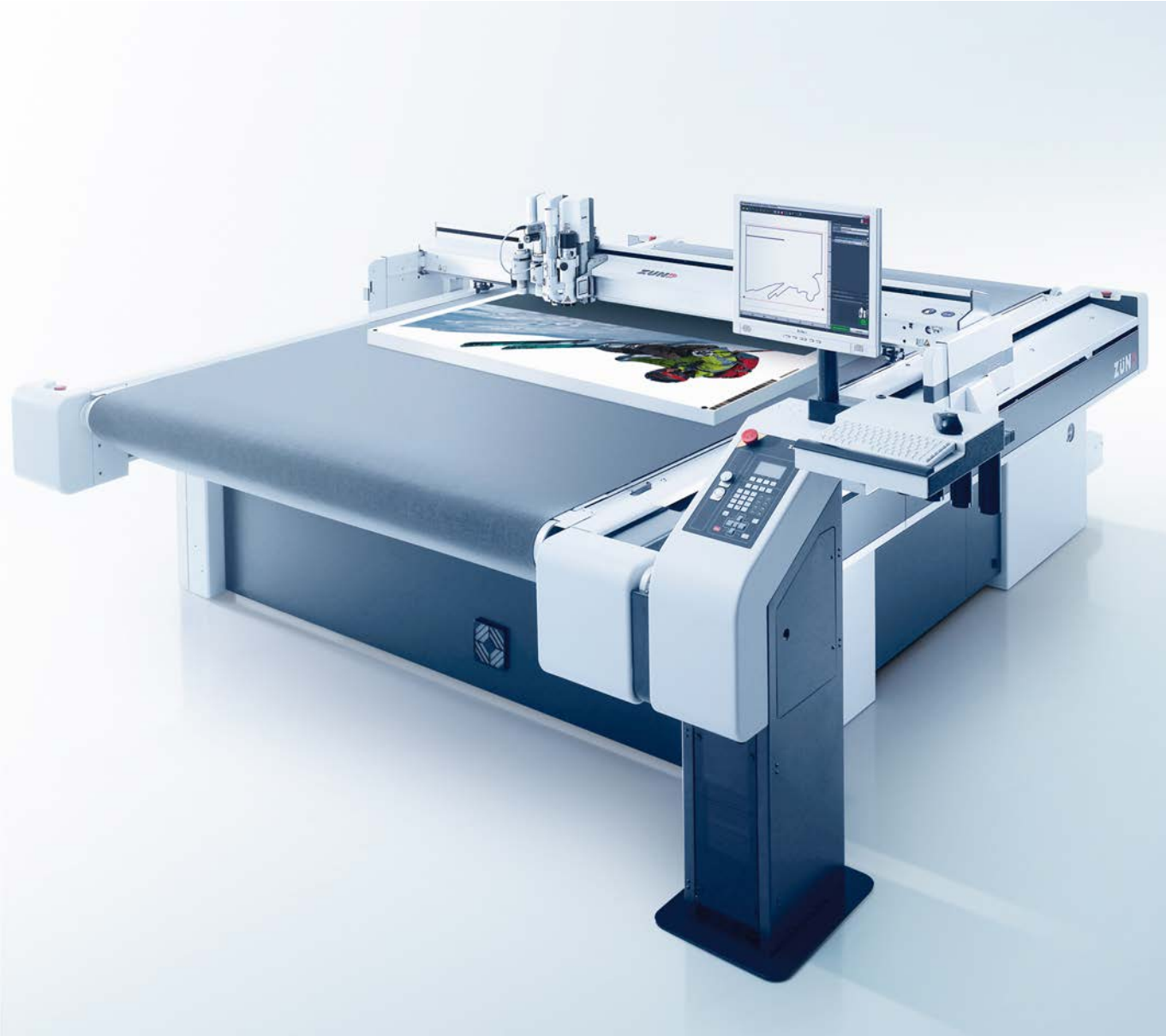

Keep it in a safe place for future use!

Original operating manual

Software-/Firmware version: FW1.77-1

Creation date: 02-2023

Contents

1 Introduction.....	7
1.1 Using the operating manual.....	8
1.2 Points to note when reading this operating manual.....	9
1.3 Publishing details.....	9
2 Product description.....	11
2.1 Important information about the product.....	11
2.2 Orientation.....	12
2.3 Product identification.....	13
2.4 Intended use.....	13
2.5 Cutter overview.....	14
2.6 Modules, tools.....	15
2.7 Material handling.....	20
2.8 Options.....	22
2.9 Accessories box.....	22
2.10 Technical description.....	24
2.11 Technical data.....	27
3 Safety.....	41
3.1 General.....	41
3.2 Proper use.....	41
3.3 Examples of reasonably predictable unintended use.....	41
3.4 Hazard warnings, important instructions.....	43
3.5 Areas of responsibility.....	45
3.6 Personnel requirements.....	45
3.7 Personal protective equipment.....	46
3.8 Rules and occupational safety.....	47
3.9 Conduct in the event of malfunctions.....	47
3.10 Danger areas.....	48
3.11 Warnings on the product.....	52
3.12 Protective devices.....	55
3.13 Mechanical hazards.....	59
3.14 Risk of burns.....	60
3.15 Electrical hazard.....	60
3.16 Risks arising from the emission of toxic dust.....	61
3.17 Risks arising from the processing of toxic materials/materials hazardous to health.....	61
3.18 Environmental hazards.....	62
3.19 Handling and storage of chemicals.....	62
3.20 Risk of fire and explosion.....	65
3.21 Danger from laser beam.....	66
3.22 Safety instructions for the operating personnel.....	66
3.23 Safety precautions for service personnel.....	67
3.24 Disposal.....	67
4 Controls and operation.....	69
4.1 Safe working practices.....	69
4.2 Controls.....	70
4.3 Menu navigation.....	75
4.4 Menus and functions.....	76

4.5	General settings.....	78
4.6	User level.....	79
4.7	Malfunctions.....	81
4.8	Daily checks prior to start-up.....	84
4.9	Behavior in dangerous situations.....	87
4.10	Start-up.....	89
4.11	operating mode.....	92
4.12	Moving the beam/module manually.....	94
4.13	Handling modules/tools.....	95
4.14	Material fixing.....	108
4.15	Material transport (optional).....	117
4.16	Integrated Tool Initialization - ITI.....	122
4.17	Automatic Router Bit Changer ARC / ARC HSK (optional).....	128
4.18	Job processes.....	129
4.19	Laser pointer, reference point.....	134
4.20	ICC camera, automatic registration (optional).....	136
4.21	Module carriage slot protective plate.....	140
4.22	Signal lights (optional).....	141
4.23	Module and tool holder (optional).....	142
5	Tips for cutting.....	143
5.1	Select tool.....	143
5.2	Selecting a blade.....	143
5.3	Preparing cutting data.....	149
5.4	Settings, speed, quality.....	149
5.5	Recognising processing errors.....	151
5.6	Oscillating cutting.....	161
5.7	Tips for increasing the rate of production.....	162
5.8	Identifying and rectifying quality problems.....	163
6	Maintenance.....	167
6.1	Safe maintenance of the machine.....	168
6.2	Tools, operating and auxiliary materials.....	168
6.3	Maintenance list for trained operating personnel.....	172
6.4	Maintenance list for authorized service technicians.....	174
6.5	Cutter maintenance mode.....	181
6.6	Service flaps and covers.....	182
6.7	Visually inspecting the machine for damage.....	187
6.8	Cleaning the machine.....	188
6.9	EMERGENCY STOP control devices function test.....	188
6.10	Cleaning/oiling the X axis, guide rails/guide carriage.....	189
6.11	Clean/oil Y axis guide rails.....	191
6.12	Y axis, oiling the guide bearing and filling the oiler.....	192
6.13	Oiling the hose routing.....	193
6.14	Clean the chipping protection, brushes.....	194
6.15	Cleaning transport elements/transport bar.....	195
6.16	Cleaning the inside of the beam.....	196
6.17	ITI, clean light barrier.....	197
6.18	Draining the maintenance unit condensate water.....	198
6.19	Replacing the vacuum turbine cooling air filter under the cutter.....	199
6.20	Replacing the vacuum turbine cooling air filter next to the cutter.....	200
6.21	Resetting 12.5/14.0 kW vacuum pump motor protection relay.....	201
6.22	Reset 2.2/2.55 kW, 4.0/4.6 kW, 5.5/6.3 kW vacuum pump, motor protection relay.....	202
6.23	ICC camera, cleaning the lens (optional).....	203
6.24	Starting up after periods of standstill.....	204
6.25	Instructions for disposal.....	205

7 Tools..... 207

8 Modules..... 209

9 Options..... 211

10 Material handling..... 213

11 Additional specifications..... 215

1 Introduction

**Dear customer,**

With your decision to purchase our product you are participating in the worldwide success of Zünd cutter systems.

The modular design of our systems provides the following benefits, among others things:

- A system solution that meets your individual requirements in terms of speed and quality.
- The availability of the most up-to-date technology thanks to continuous development.

Our approach

Constant and intensive cooperation with experienced users is essential for developing innovative and practical solutions. We are, therefore, grateful for any comments or suggestions on how we can improve.

Contact

Zünd Systemtechnik AG
Industriestrasse 8
9450 Altstätten, Switzerland

Tel: +41 71 554 8100

info@zund.com

www.zund.com

1.1 Using the operating manual

The supplied operating manual is intended to enable you to operate the machine safely, perform routine maintenance and use the machine optimally in every way.

To do this, you need to be able to find what you need in the documentation.

Scope of the operating manual



Volume 1 - Operating instructions

This volume contains information on engineering, commissioning, operation and maintenance of the machine.



Volume 2 - Service manual

This volume contains information on the design of the machine and on servicing by authorized service technicians. The service manual is not included in the scope of delivery of the machine.



Spare parts catalog

The spare parts catalog is not included in the scope of delivery of the machine.

Structure of the operating instructions

The operating instructions consist of separate sections, which are numbered consecutively and arranged according to the ring binder tabs.

The table of contents provides information on the structure of the individual sections.

Indication of optional accessories

There are many optional accessories available for the machine. Descriptions of optional additional equipment are labeled in the operating manual with the wording **(optional)** .

Safekeeping of the documentation

Always keep Volume 1 of the "User manual" close at hand in the vicinity of the workstation.

Current status of the documentation

In order to ensure that the operating manual always remains complete and up to date, the following must be observed:

- Do not remove individual documents.
- Request copies of missing or illegible pages from the manufacturer, or download them from the Zünd homepage and print them out.
- If any new documentation is provided as a result of conversions, add it immediately.
- Replace changed documents and destroy the old version.
- If the documentation exists in more than one language, ensure that all languages are kept up to date.

1.2 Points to note when reading this operating manual

Text references

Chapter headings are numbered consecutively in the chapters, with the first figure corresponding to the chapter number. Where reference is made to sections outside the current chapter, note the first figure and turn to the corresponding chapter, which contains the cited section. See chapter 2.4 Cutter; overview, for example, leads to chapter 2 Product description, which contains section 4 Cutter overview.

Block diagrams and simplified representation

Note that all representations are provided for general information and do not necessarily correspond to the latest version of the machine.

Dimensional information

Dimensional information is listed in the SI/US units, depending on the installation site.

1.3 Publishing details

Layout, illustration, and print

Zünd Systemtechnik AG - Technical Communications Department

© Copyright

Zünd Systemtechnik AG

2 Product description

This chapter contains information on the following:

- Representation conventions in the operating manual
- Usage possibilities of the machine
- Structure of the main components
- Important technical data
- General technical description of the machine

2.1 Important information about the product



Tip:

"Tip" refers to useful information which enhances the usability and prolongs the service life of the machine or makes the work process significantly easier.



Tip:

With tips combined with the sheet we give you usage tips and useful information which can improve the energy efficiency of the machine or optimize its environmental effects.

Important:

Usage tips and important machine operating information are labeled with **Important**.

2.2 Orientation

Directions such as "right, left" or "front, back" relate to the operator's view of the machine during operation.

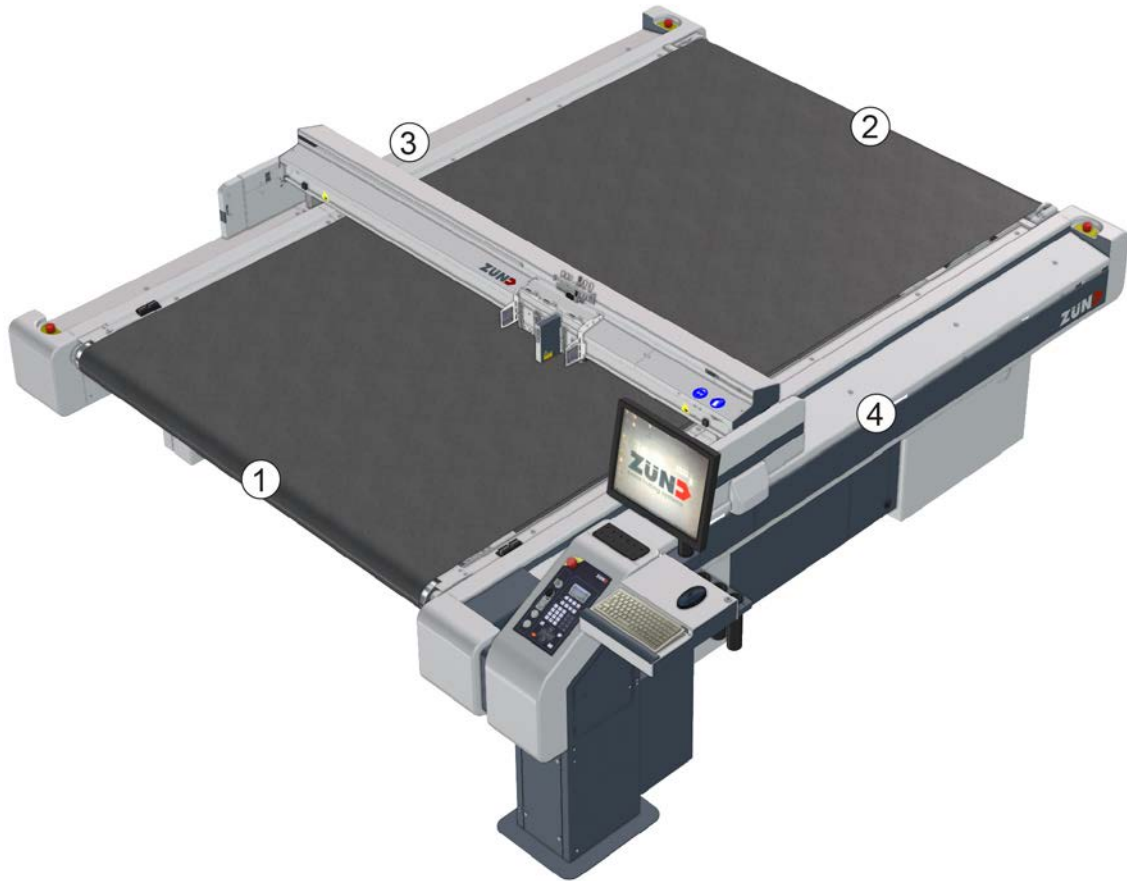

- 1 front
- 2 back
- 3 left
- 4 right

2.3 Product identification

2.3.1 Rating plate

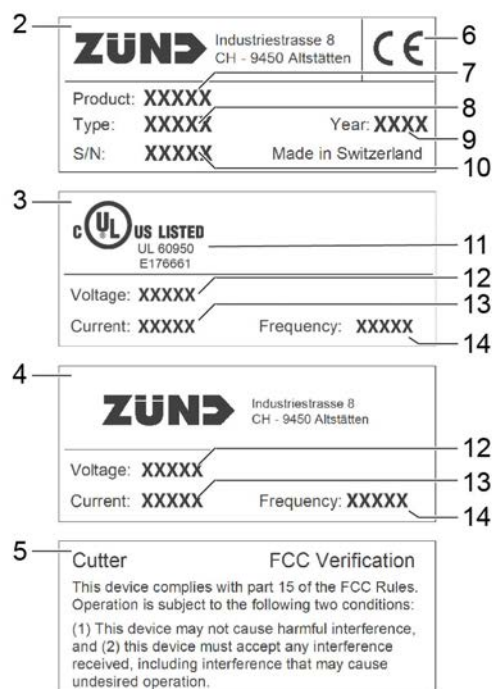

1	Position of the signs	8	Type designation
2	Rating plate	9	Year of manufacture
3	Additional UL sign	10	Serial number
4	Additional connection values	11	UL mark of conformity
5	Additional FCC sign	12	Nominal voltage
6	CE mark of conformity	13	Rated current
7	Product name	14	Frequency

2.4 Intended use

The cutter system can be used for the following purposes:

- As an output station for CAD/CAM data.
- For processing and labeling of materials.

The intended use and the usage restrictions are also dependent on the available tool and material transport system, which are described in the "Tools", "Modules" and "Material handling" chapters.

2.5 Cutter overview

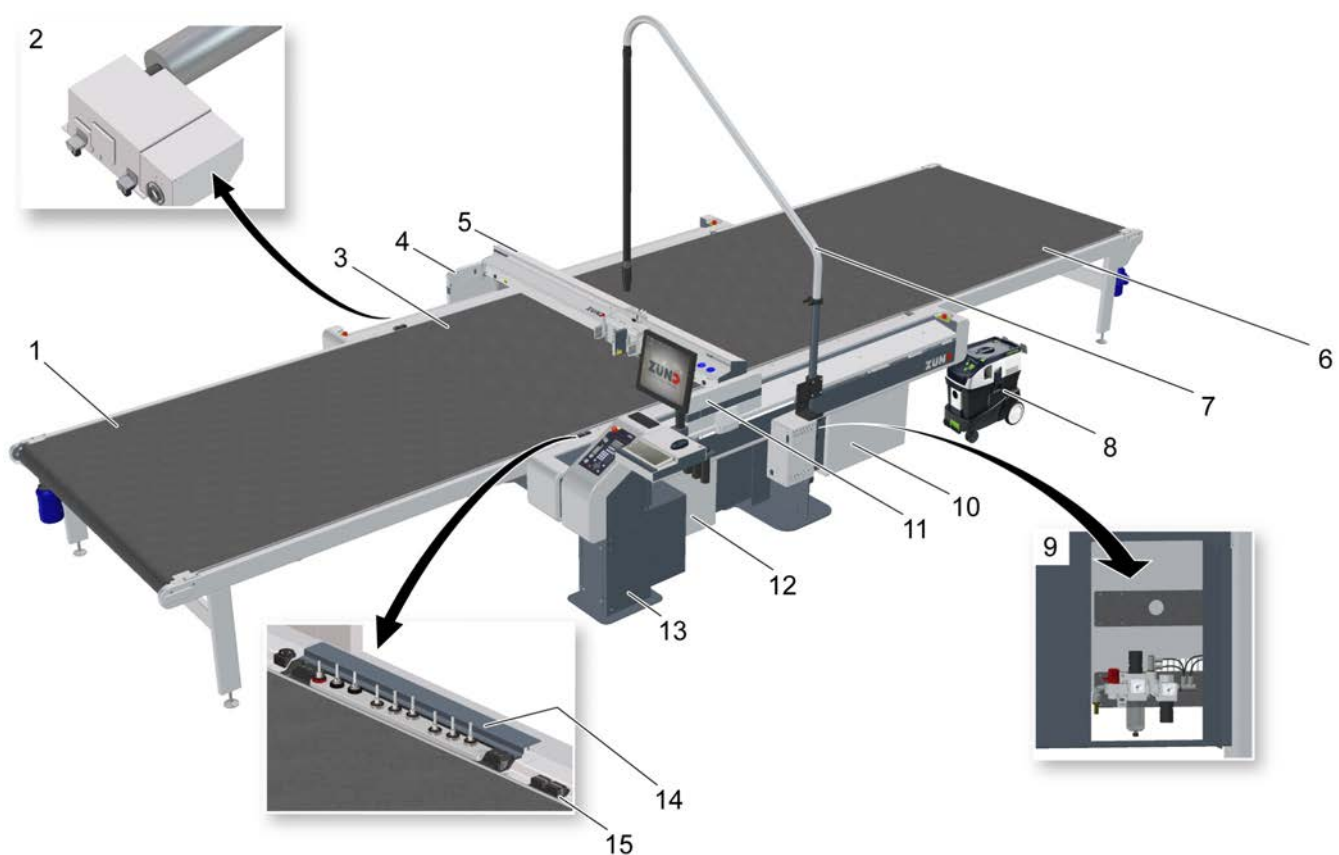

- 1 Cutter extension, front (optional)
- 2 Vacuum generator (optionally turbine or pump)
- 3 Working area
- 4 Left safety device
- 5 Beam
- 6 Cutter extension, rear (optional)
- 7 Boom with converter (optional)
- 8 Extractor (optional)
- 9 Maintenance unit
- 10 Power box
- 11 Right safety device
- 12 Electronics unit
- 13 Control panel with optional workstation
- 14 Automatic Router Bit Changer - ARC / ARC HSK
- 15 Integrated Tool Initialization - ITI (optional)

2.6 Modules, tools

Zünd cutters are highly specialized and can be easily converted to process other materials through the use of modules and tools.

As standard, three modules can be fastened onto the module carriage of the G3.



Tip:

You can find detailed information in section [Handling modules/tools](#) on page 95 as well as in the individual operating manuals of your modules and tools.

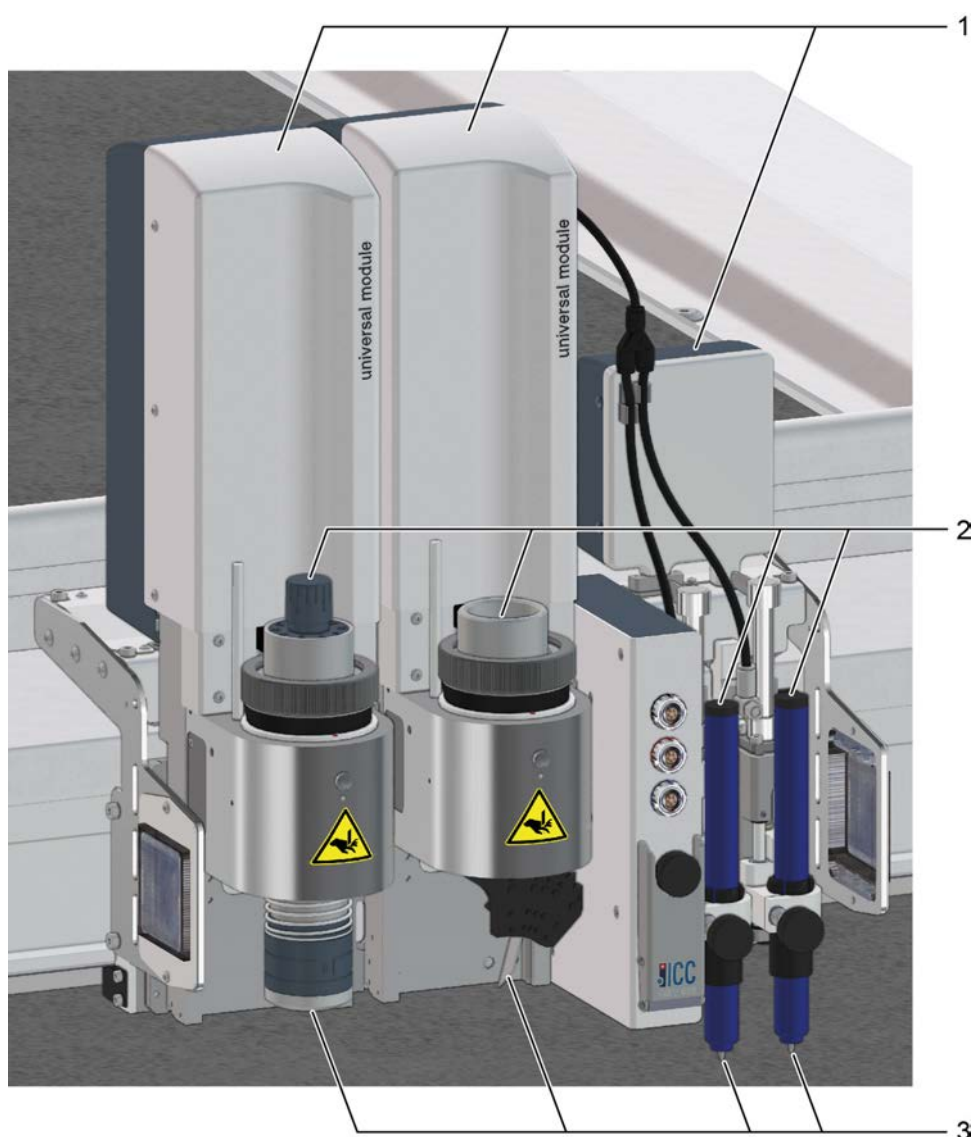

- 1 Module (e.g., UM, MAM)
- 2 Tool (e.g., UCT, VCT, SDT)
- 3 Tool insert: router, blade, pen

2.6.1 Universal applications

Universal Module - UM



Universal carrier modules for a wide range of tools.

- **UM-ZS:** high-speed Z axis
- **UM-ZP:** very strong Z axis
- **UM-120:** specially for cutters with 120 mm beam height
- **UM-60L:** especially for using very large tools

Tools for use in the UM



Electric Oscillating Tool - EOT

Cutting tool with high oscillation frequency for soft and medium hard materials.



Electric Oscillating Tool - EOT-250

Robust tool with high-performance electric drive for processing thick cardboard and leather materials.



Pneumatic Oscillating Tool - POT

Powerful cutting tool with large oscillation stroke for hard and tough materials of up to 50 mm thickness.



Power Rotary Tool - PRT

Robust and powerful tool for technically demanding textiles, carbon fiber and glass fiber fabrics.



Driven Rotary Tool - DRT

Tool for technically demanding textiles and textile materials. The powered rotary blade enables a very high processing speed.

**Wheel Knife Tool - WKT**

Low-maintenance tool for the processing of glass and carbon fiber fabrics as well as technically demanding textiles for insert cutting.

**Universal Cutting Tool - UCT**

Universally usable cutting tool for materials of up to 5 mm thickness.

**Scoring Cutting Tool - SCT**

Combination tool for scoring and cutting cardboard and coating blankets of up to 5 mm material thickness.

**V-Cut Tool - VCT**

Tool with five different cutting angles. Creation of complex 3D constructions from high expansion foam or sandwich boards.

**Passepartout Tool - PPT**

Exact 45° oblique cuts in constantly high quality.

**Perforating Tool - PTT1**

Ideal tool for creating precise perforations in corrugated cardboard, solid board, polypropylene, and foil.

**Kiss Cutting Tool - KCT**

Kiss-Cutting tool with adjustable pressing pressure for the processing of numerous vinyl materials.

**Universal Routing Tool - URT**

Cost-effective routing and engraving tool.

**Creasing Tools - CTT1/2/3**

Creasing of various types of materials. The pressing pressure is separately adjustable laterally and longitudinally along the shaft.

**Universal Drawing Tool - UDT**

Drawing tool for the use of standard commercial leads in various line thicknesses.



Raster Braille Tool - RBT

Efficient procedure for the creation of tactile Braille markings (for the blind).

2.6.2 Routing, engraving:

Router Module - RM-A



Universally usable router system, fitted with a 1.0 kW motor spindle.

- Efficient dust extraction, actively air-cooled
- Surface compensation for precise depth setting
- Optional Minimal Quantity Lubrication- MQL for processing soft aluminum alloys



Motor spindle with 1.0 kW for processing various types of materials.

Router Module - RM-L



Universally usable router system, fitted with a 3.6 kW motor spindle.

- Efficient dust extraction system
- Water-cooled motor spindle
- Surface compensation for precise depth setting
- Integrated Minimal Quantity Lubrication - MQL for processing soft aluminum alloys

2.6.3 Laser cutting

Laser module – LM 100W



Laser module for cutting with simultaneous edge sealing for polyester textiles (Cut & Seal).

- Powerful 100 W CO₂-Laser
- Laser class 1
- Cutting speeds up to 745 mm/s.
- Material thickness up to 2 mm.

2.6.4 Punching, perforating

Punch Modules - PUM



High performance tools for perforating leather materials, rubber and textiles w up to 8 holes per second.

2.6.5 Drawing, marking, labeling

Marker Modules - MAM



Marking and labeling of various types of materials. Use of standard commercial leads.

- **MAM-S:** 1 drawing tool, pneumatic
- **MAM-D:** 2 drawing tools, pneumatic

2.7 Material handling

2.7.1 Cutter with static work surface



Manual loading/unloading on the cutter work surface. The working surface is protected against damage using a cutting board.

2.7.2 Cutter with material transport



The conveyor belt is a cutting board and conveyor belt at the same time. Cut parts are automatically transported away from the cutting area while the cutter is loaded at the same time. The material transport allows the production of orders that are longer than the cutter. Transport elements fix the material during feeding.

2.7.2.1 Cutter extensions



Cutter extensions are available for installation on front and/or rear of the cutter in the following sizes:

- Extension along the length of the whole cutter working surface (L) (CE1600, CE2500, CE3200, CE3500).
- Extension along the length of half of the cutter working surface ($\frac{1}{2}$ L) (CE800, CE1250, CE1600).

The material supply/removal is carried out while the cutter is completing the jobs.

2.7.2.2 Collection tray



The collection tray is a practical device with which the cutting waste and cut parts are collected. It ensures a clean working environment. For emptying, the tray can be removed from the cutter in just a few steps.

2.7.2.3 Material guide roller

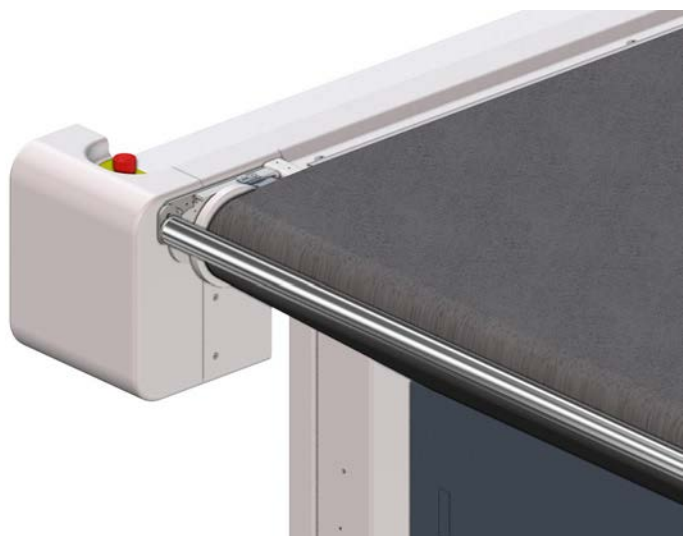

The material guide roller effectively prevents the formation of folds of textile materials. In this process, the material is fed over a guide roller.

2.8 Options

2.8.1 ICC camera



The ICC camera allows perfect registration in which the exact position of printed material on the processing surface is determined.

The integrated laser pointer is used as an aid for the precise determination of the reference point. Electrically driven tools can also be connected to the camera.

2.9 Accessories box

The accessories box is delivered with the cutter. The accessories box contains the tools and operating and auxiliary materials needed for maintaining the cutter. The contents are provided appropriately for the cutter.

Contents (sample)

Accessories	Quantity	Task	Conveyor	Static	PU
Allen screwdriver 4 x 170 mm	1 pc.	Assembling/ disassembling modules	x	x	x
Special guide rail oil	25 ml	Oil for the X/Y axis guide rails, carriage and bearings	x	x	x
Lubrication set, X axis guide rails	1 pc.	Oil for the X/Y axis guide rails, carriage and bearings	x	x	x
Staple gun	1 pc.	Replacing the conveyor belt	x		
Dosing gun KPM 250 ECON	1 pc.	Replacing the conveyor belt	x		
19 mm tape, double- sided	1 pc.	Fixing the cutting board		x	
Flat open-ended spanner SW14	1 pc.	Tension conveyor belt with 2 auxiliary drives	x		x
Special lubricant for PE/ PVC tubes	20 ml	Service	x	x	x
Teflon grease	20 ml	Service	x	x	x
Soldering fluid brush	1 pc.	Service	x	x	x
Vacuum element spacers	6 pcs.	Service	x	x	x
Pneumatic blind plugs	2 pcs.	Service	x	x	x
Glass tube safety guards (various)	5 pcs.	Service	x	x	x
19 mm adhesive tape	1 pc.	Service	x	x	x

2.10 Technical description

Zünd high performance cutters enable efficient and precise processing of the most varied of materials. With the modular tool and material handling system, you can adapt your machine to your individual requirements. Define the production requirements and put together your tailor-made cutter configuration from the Zünd kit concept.

2.10.1 Base machine

Working area / vacuum plate

The working area consists of a robust aluminum construction, designed as a perforated sheet. Vacuum zones are arranged under this perforated sheet which are connected to a high-performance vacuum generator via a distributor.

The vacuum is used for holding down and tightening the material to be processed. The intelligent cutter control unit permits sequential activation/deactivation of the individual vacuum zones and therefore reduces energy consumption.

Electronics unit - E-box

The electronics unit is housed in the front right-hand side of the cutter and is only accessible for service personnel via a removable cover. The cutter control is housed in the electronics unit.

Power box - P-box

The power box is housed in the rear right-hand side of the cutter and is only accessible for service personnel via a removable cover. The power box contains the power supply of the complete cutter and is activated/deactivated with the main switch. The connection of the individual consumers takes place using software control, if required.

Maintenance unit

The air pressure for the respective consumers is adjusted via a maintenance unit. The maintenance unit is accessible via a service door so that settings or maintenance work can be carried out.

2.10.2 Movement system

The G3 series has four electronically driven axes:

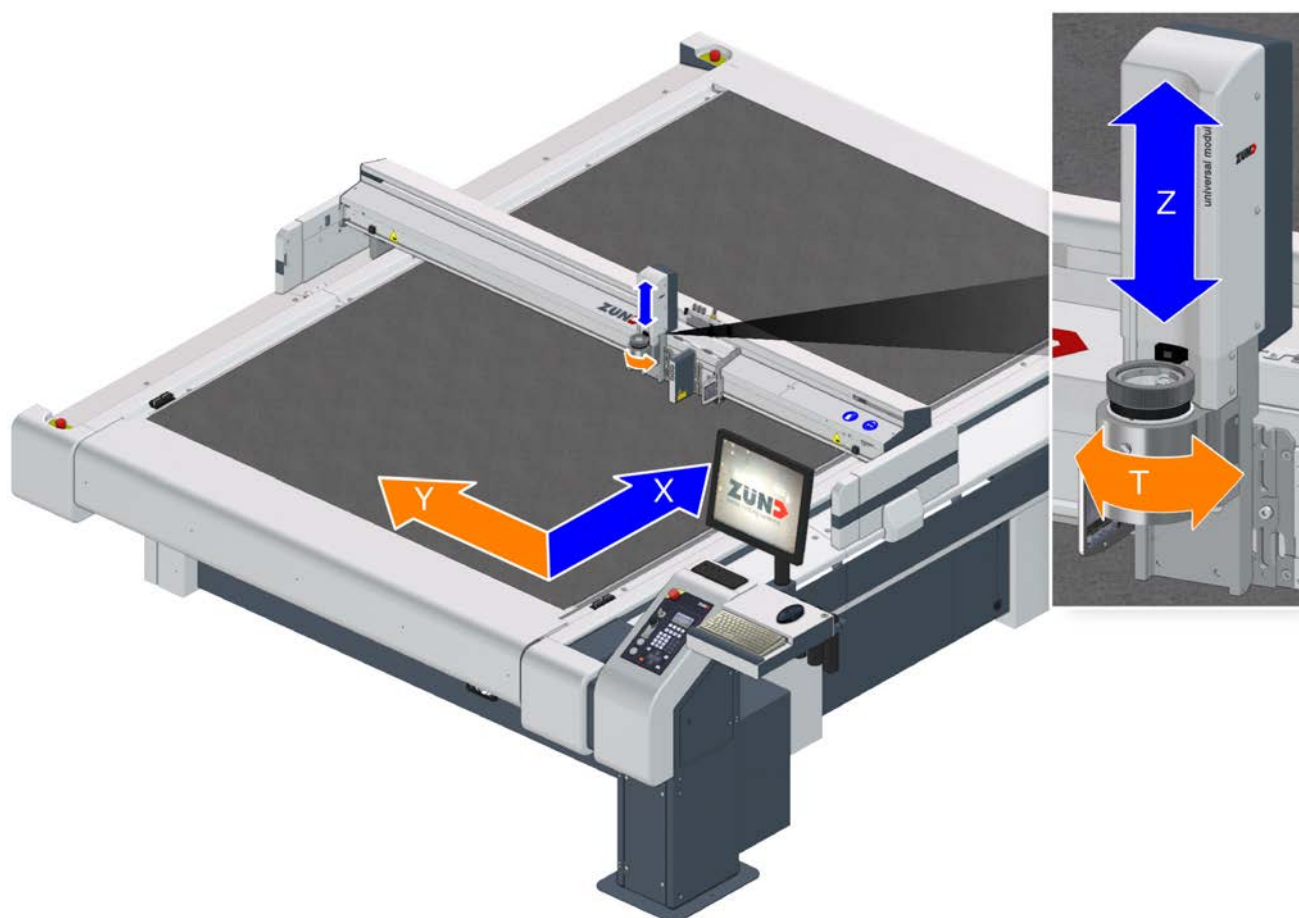

Axis	Function	Movement system
X	Beam movement	Drive via toothed belt/steel belt
	Material transport, material transport extension (optional)	Conveyor clamping elements, transport elements, auxiliary drive (optional)
Y	Movement of the module carriage	Drive via toothed belt/steel belt
Z	Height adjustment of the module	Example Universal Module, Router Module
T	Rotary movement of the module	Example Universal Module

X axis - beam

The beam is driven by a high-performance direct drive. This increases accuracy as well as the processing speed.

The design ensures that it works without play and it also minimizes wear on the drive system. The beam is supplied with control signals and compressed air via an energy chain. All drive parts are protected against direct access or contamination using covers.

X axis - material transport

The material transport takes place via conveyor clamp elements and transport elements on the beam, which move the conveyor belt including the material to be processed via the beam movement. Additionally, an auxiliary drive is used for larger cutters or when using cutter extensions.

Y axis - module carriage

The module carriage is driven by a motor via a toothed belt/gear mechanism and a toothed belt/steel belt. The design ensures that it works without play and it also minimizes wear on the drive system. The module carriage is supplied with control signals and compressed air via an energy chain. All drive parts are protected against direct access/contamination using covers.

Z axis - height adjustment of the module

Machine-controlled setting of the processing height (e.g. Universal Module).

T axis - rotary movement of the module

Modules with integrated T axis (e.g. Universal Module).

2.11 Technical data

2.11.1 Dimensions

2.11.1.1 Base cutter (mm)

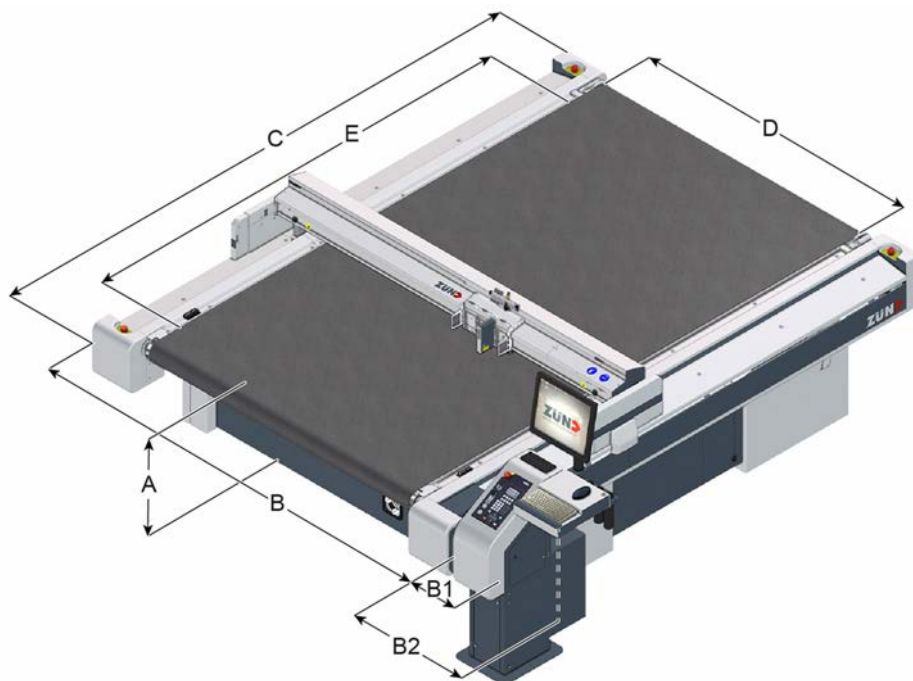

The effectively usable working surface (D x E) depends on the tool or module.

Type (mm)	A	B	B1	B2	C	D	E
M-1600 M-2500	830	2055	300	624	2512 3412	1330	1600 2500
L-2500 L-3200		2525			3412 4112		1800
XL-1600 XL-3200		2995			2512 4112	2270	
2XL-1600 2XL-3200		3465			2512 4112		2740
3XL-1600 3XL-2500 3XL-3200		3935			2512 3412 4112	3210	

2.11.1.2 Base cutter (inch)

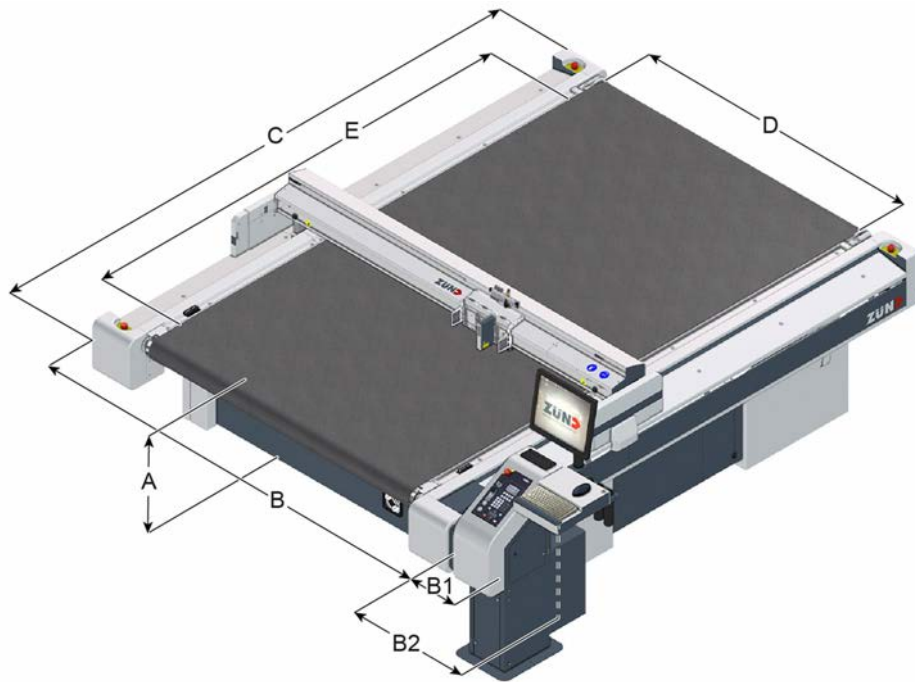

The effectively usable working surface (D x E) depends on the tool or module.

Type (in)	A	B	B1	B2	C	D	E
M-1600 M-2500	32.7	80.9	11.8	24.6	98.9 134.3	52	63 98
L-2500 L-3200		99.4			134.3 161.9	71	98 126
XL-1600 XL-3200		117.9			98.9 161.9	89	63 126
2XL-1600 2XL-3200		136.4			98.9 161.9	108	63 126
3XL-1600 3XL-2500 3XL-3200		154.9			98.9 134.3 161.9	126.5	63 98 126

2.11.1.3 Cutter extension - CE (mm)

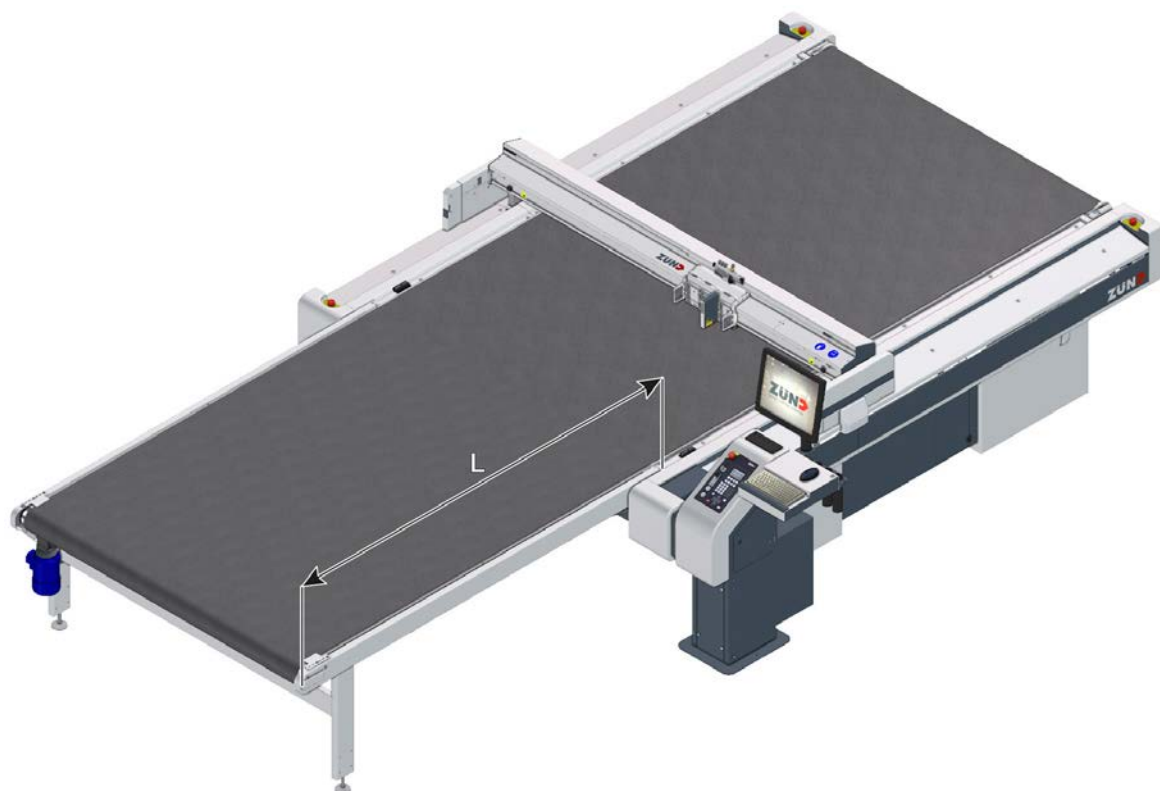

Type	CE0800 745	CE1250 1195	CE1600 1545	CE2500 2445	CE3200 3145	CE3500 3445
M-1600	x		x		x	
M-2500		x		x		
L-2500		x		x		
L-3200			x		x	x
XL-1600	x		x		x	
XL-3200			x		x	x
2XL-1600	x		x		x	
2XL-3200			x		x	x
3XL-1600	x		x		x	
3XL-2500		x		x		
3XL-3200			x		x	x

2.11.1.4 Cutter extension - CE (inch)

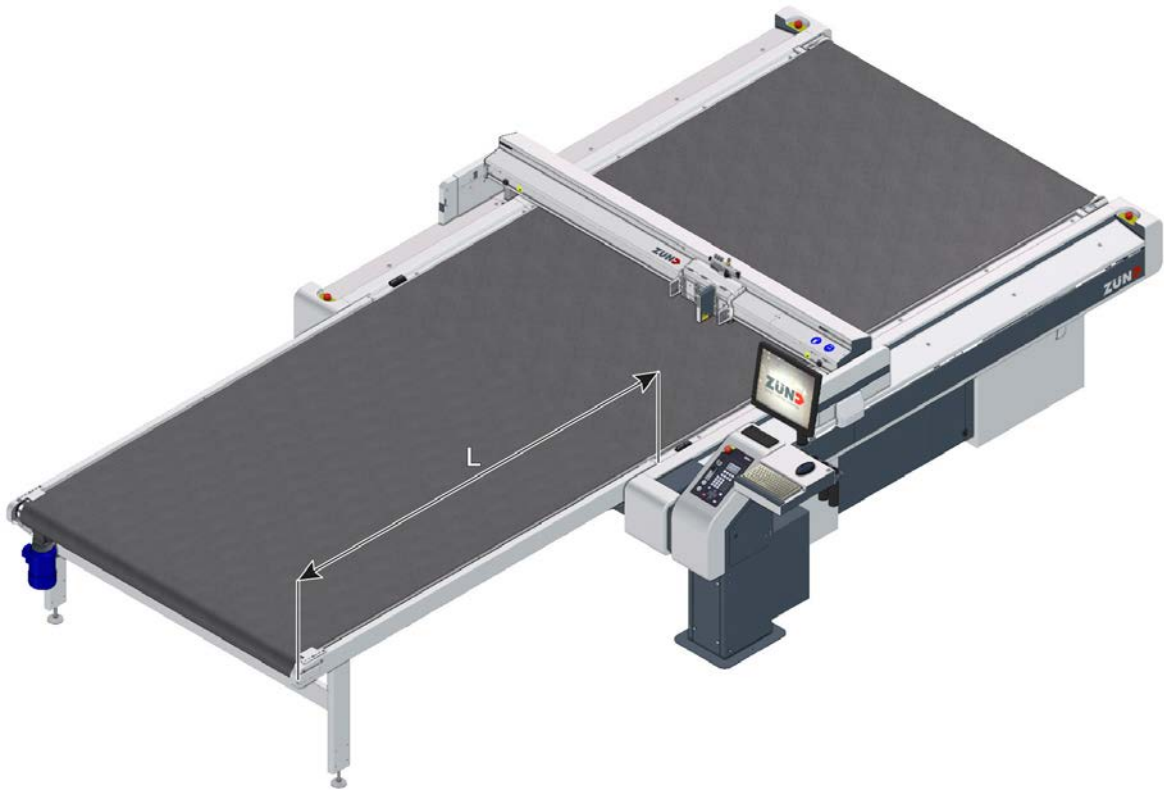

Type	CE0800 29.33	CE1250 47.04	CE1600 60.82	CE2500 96.26	CE3200 123.82	CE3500 135.63
M-1600	x		x		x	
M-2500		x		x		
L-2500		x		x		
L-3200			x		x	x
XL-1600	x		x		x	
XL-3200			x		x	x
2XL-1600	x		x		x	
2XL-3200			x		x	x
3XL-1600	x		x		x	
3XL-2500		x		x		
3XL-3200			x		x	x

2.11.2 Weights

2.11.2.1 Base cutter (kg)

Type	Beam height (mm)	Weight (kg)	max. floor load (kg/m ²)
M-1600 M-2500	30/60	670 840	200
L-2500 L-3200	30/60 30/60/120	970 1120	
XL-1600 XL-3200	30/60 30/60/120	890 1290	
2XL-1600 2XL-3200	30/60	980 1420	
3XL-1600 3XL-2500 3XL-3200	30/60	1120 1400 1610	

2.11.2.2 Base cutter (lbs)

Type	Beam height (in)	Weight (lbs)	max. floor load (lbs/in ²)
M-1600 M-2500	1.2/2.4	1463 1837	450
L-2500 L-3200	1.2/2.4 1.2/2.4/4.3	2129 2446	
XL-1600 XL-3200	1.2/2.4 1.2/2.4/4.3	1954 2823	
2XL-1600 2XL-3200	1.2/2.4	2140 3110	
3XL-1600 3XL-2500 3XL-3200	1.2/2.4	2457 3080 3540	

2.11.2.3 Material weight (kg)

Type	max. material weight (kg)	max. material weight (kg/m ²)
M-1600	63	30
M-2500	99	
L-2500	135	
L-3200	173	
XL-1600	109	
XL-3200	218	
2XL-1600	132	
2XL-3200	263	
3XL-1600	154	
3XL-2500	241	
3XL-3200	308	

2.11.2.4 Material weight (lbs)

Type	max. material weight (lbs)	max. material weight (lbs/in ²)
M-1600	138	66
M-2500	218	
L-2500	297	
L-3200	381	
XL-1600	240	
XL-3200	480	
2XL-1600	290	
2XL-3200	580	
3XL-1600	340	
3XL-2500	531	
3XL-3200	680	

2.11.3 Electrical connection

2.11.3.1 Base machine

Electrical connection 400 V, 50/60 Hz

	Value	Unit
Voltage	3-phase, 400 L1, L2, L3, N, PE	V
Mains frequency	50/60	Hz
Power input - 3 phases (without vacuum generator)	3.6	kW
Current consumption, 3 phases (without vacuum generator)	max. 12	A
Mains fuse, min. ¹	16	A

Electrical connection 200 V, 50/60 Hz

	Value	Unit
Voltage	3 phase, 208 L1, L2, L3, N, PE	V
Mains frequency	50/60	Hz
Power input - 3 phases (without vacuum generator)	3.6	kW
Current consumption, 3 phases (without vacuum generator)	max. 12	A
Mains fuse, min. ¹	16	A

¹)Only applies for the base machine. The minimum requirements for the mains fuse increase depending on the vacuum generator.

2.11.3.2 Vacuum generator



Tip:

For additional data, see the rating plate or the Chapter "Additional specifications" in the original operating manual

The vacuum generator is selected according to the following criteria:

- Cutter model, cutter size
- Purpose of use
- Properties of the processing material
- local mains voltage and frequency

Vacuum turbine 1 - 9 kW

	Value	Unit
Voltage	L1, L2, L3, PE, 400	V
Mains frequency	50/60	Hz
Power input - 3 phases	1 - 9	kW
Mains fuse, min.	32	A

Vacuum turbine 1 - 9 kW

	Value	Unit
Voltage	L1, L2, L3, PE, 208	V
Mains frequency	50/60	Hz
Power input - 3 phases	1 - 9	kW
Mains fuse, min.	50	A

Vacuum turbine 1 - 15 kW

	Value	Unit
Voltage	L1, L2, L3, PE, 400	V
Mains frequency	50/60	Hz
Power input - 3 phases	1 - 15	kW
Mains fuse, min.	32	A

Vacuum turbine 1 - 15 kW plus

	Value	Unit
Voltage	L1, L2, L3, PE, 400/480	V
Mains frequency	50/60	Hz
Power input - 3 phases	1 - 15	kW
Mains fuse, min.	32	A

Vacuum pump 2.2/2.55 kW

	Value	Unit
Voltage	L1, L2, L3, PE, 208/400	V
Mains frequency	50/60	Hz
Power input - 3 phases	2.2/2.55	kW
Mains fuse, min.	32	A

5.5/6.3 kW vacuum pump

	Value	Unit
Voltage	L1, L2, L3, PE, 208/400	V
Mains frequency	50/60	Hz
Power input - 3 phases	5.5/6.3	kW
Mains fuse, min.	32	A

12.5/14.5 kW vacuum pump

	Value	Unit
Voltage	L1, L2, L3, PE, 400/480	V
Mains frequency	50/60	Hz
Power input - 3 phases	12.5/14.5	kW
Mains fuse, min.	32	A

2.11.4 Environmental conditions

	Value
Operating temperature	+10 °C to +35 °C
Storage temperature	-20 °C to +55 °C
Relative humidity	10 - 80%, non-condensing

2.11.5 Compressed air supply**2.11.5.1 Compressed air connection requirements****Important:**

The compressed air connection must fulfill the following requirements:

- **Air purity:** class 2.4.2 according to ISO 8573-1:2010
- **Air pressure:** 0.6 - 1.0 MPa depending on configuration

- **Air consumption:** base machine 20 l/min. 20 - 400 l/min depending on configuration

2.11.5.2 Compressed air settings

Compressed air regulator P1

	Air pressure [MPa]		max. air consumption [l/min]
	Maintenance unit	House connection	
Punch Module - PUM	0.7 - 0.8	0.7 - 1.0	150
Router Module - RM-A QC			40
Router Module - RM-L	0.6	0.6 - 1.0	130
Router Module - RM-L and ARC-HSK			160

Compressed air regulator P2

	Air pressure [MPa]		max. air consumption [l/min]
	Maintenance unit	House connection	
Electric Oscillating Tool - EOT-250	0.6	0.6 - 1.0	70
Power Rotary Tool - PRT			75
Universal Routing Tool - URT			60
Marker Module - MAM			20
Extraction Switch Module - ESM			20
BHS board feeder	0.6	0.6 - 1.0	50
BHS sheet removal			50
BHS separating aid			50

	Air pressure [MPa]		max. air consumption [l/min]
	Maintenance unit	House connection	
Automatic Router Bit Changer - ARC	0.6	0.6 - 1.0	100
Base machine (vacuum elements)			covered with base consumption
Center winder roll-up unit			

Compressed air regulator P3

	Air pressure [MPa]		max. air consumption [l/min]
	Maintenance unit	House connection	
Router Module - RM-A	0.45	0.6 - 1.0	40
Minimal Quantity Lubrication - MQL			70
Carbon fiber protection			24
Material transport (transport elements, conveyor clamping elements)			covered with base consumption
Board loading device			

Compressed air regulator P4

	Air pressure [MPa]		max. air consumption [l/min]
	Maintenance unit	House connection	
Pneumatic Oscillating Tool - POT	0.8	0.8 - 1.0	400
Scoring Cutting Tool - SCT			20
Passepartout Tool - PPT	0.6 - 0.8	0.6 - 1.0	20

2.11.6 Performance features

Accuracy

	Value	Unit
Resolution of measuring system	0.005	mm
Positioning accuracy at a constant temperature	±0.1	mm
Repeat accuracy	±0.03	mm
Evenness of the worktop	0.4	mm

Cutting performance

	Value	Unit
Speed in vector direction	1 - 1414	mm/s
Max. acceleration in vector direction ¹	9.3	m/s ²
max. permissible printing force of the printhead (creasing)	300	N

¹depending on the module equipment and cutter size

2.11.7 Emissions

Noise emission

Cutter noise emission

< 75 dB (A)

Depending on the cutting technology used, the machined material, the vacuum generator and the environmental conditions, the value can vary between <75 dB and ~85 dB.

Electromagnetic emissions

The G3 series meets requirements of the following technical standards:

- EN 61000-6-2 EMC, interference resistance in industrial environments
- EN 61000-6-4 EMC, emission standard for industrial environments

Please ask the manufacturer if you wish to view to the test reports.

FCC approval

Note:

This equipment has been tested and found to comply with the limits for a Class A digital device, pursuant to part 15 of the FCC Rules. These limits are designed to provide reasonable protection against harmful interference when the equipment is operated in a commercial environment. This equipment generates, uses, and can radiate radio frequency energy and, if not installed and used in accordance with the instruction manual, may cause harmful interference to radio communications.

Operation of this equipment in a residential area is likely to cause harmful interference, in which case the user will be required to correct the interference at its own expense.

Note:

Changes or modifications not expressly approved by the party responsible for compliance could void the user's authority to operate the equipment.

3 Safety

This chapter contains information on the following:

- Definition of the intended use of the machine
- Generally applicable safety instructions and safety regulations to be observed
- Explanation of the meaning of symbols and pictograms which are used in this manual and in signs on the machine
- Overview of protective devices on the machine
- Listing of the required protective equipment
- Information on the applicable requirements for operating and maintenance personnel

Specific handling-related and situation-related safety instructions are given in the corresponding work steps in the following chapters of this manual and in other parts of the documentation.

3.1 General

Your safety – as the operator, service engineer or otherwise – is the primary concern. Certain situations, problems or faults that may occur on the machine could put your safety at risk if you are not aware of the steps you should take to avoid the resulting dangers.

State-of-the-art technology

The supplied machine corresponds to the state-of-the-art at the time of delivery.

However, the equipment may pose dangers if the safety instructions in this guide are not observed and implemented.

3.2 Proper use

Proper use of the machine is essential for its safe operation.

The equipment supplied is listed and labeled and indicates the usage possibilities of the machine. The machine is intended for use as an output device for CAD/CAM data for labeling and processing materials arranged on the table plate. Proper use and the usage restrictions are dependent on the module and tool system used and the available material transport system. Any other or further use is deemed improper. The user bears sole liability for any damage arising from improper use!

Use of the machine shall also be regarded as proper when:

- All nationally applicable safety regulations are complied with.
- The safety instructions in this operating manual are observed.
- The operating conditions are adhered to and the prescribed materials are used.

3.3 Examples of reasonably predictable unintended use

Unintended use of the machine can have the following consequences:

- serious injuries
- serious material damage to the machine
- loss of warranty

Examples of reasonably predictable unintended use of the machine include:

- Use of materials that are not defined in the contract and in this operating manual.
- Failure to observe the applicable parameters for the processing of the relevant material.
- Maintenance work on an unsafe machine.
- Failure to follow the operating instructions.
- Placing objects on the work surface.
- Processing of materials that are too large or too heavy.
- Processing of materials that are not fixed or are not adequately fixed.
- Processing of unsuitable materials such as steel, for example.
- Usage of a tooling system that is not intended for use with the material or the machine.
- Operating the machine without the designated protective devices.
- Use of modified module and tooling systems.
- Installation of spare parts and use of accessories and resources not approved by the manufacturer.
- Constructional changes to the machine, without subsequent risk assessment.
- Failure to observe the maintenance requirements.
- Failure to react to signs of wear and damage.
- Servicing work performed by untrained or unauthorised personnel.
- Operating the machine even though the operating instructions are incomplete or unavailable in the local language.
- Deliberate or careless interference with the machine during operation.
- Bridging or altering the protective equipment.

3.4 Hazard warnings, important instructions

Explanation of the notes

Both in the operating manual and on the device itself, dangers and important instructions are designated by special symbols and signal words as follows:



Danger:

The safety instruction **Danger**

- refers to imminent danger
- refers to operational and service risks
- warns of adverse health effects or even life-threatening injuries



Warning:

The safety instruction **Warning**

- refers to a dangerous situation
- refers to operational and service risks
- warns of adverse health effects or even life-threatening injuries



Caution:

The safety instruction **Caution**

- refers to a dangerous situation
- refers to operational and service risks
- warns of minor reversible injuries and other serious material damage and consequential damage



Note:

The safety instruction **Note**

- refers to operational and service risks
- warns of serious damage to the machine and other property damage and consequential damage



Tip:

Tip in combination with the light bulb refers to user tips and useful information which enhance the usability, prolong the service life of the machine and make the work significantly easier.



Tip:

With tips combined with the sheet, we provide usage tips and useful information which can improve the energy efficiency of the machine or optimize its environmental effects.

Important:

Usage tips and important information

Structure of the hazard warnings

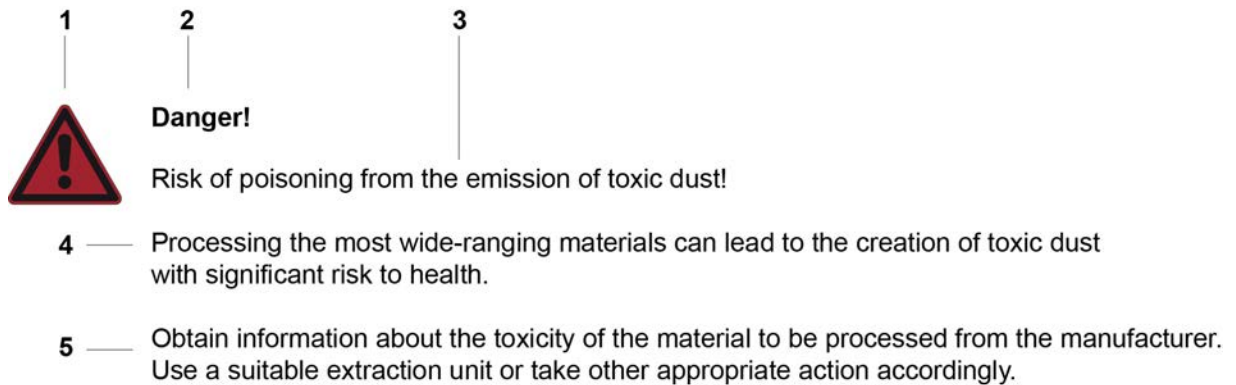

- 1 Hazard symbol with the corresponding signal color
- 2 Signal word corresponding to the danger resulting from the situation
- 3 Description of the danger
- 4 Description of the consequences which could result from this hazardous situation
- 5 Possible actions and codes of conduct to prevent the hazard from occurring or to avert possible hazardous situations

3.5 Areas of responsibility

Manufacturer's areas of responsibility

- The manufacturer is responsible for the safe condition of the machine on delivery, including operating manual and accessories, according to the sales documentation.

Areas of responsibility of the owner or person authorised by them:

- Ensuring that only adequately trained personnel who have been properly instructed and have read and understood the content of the safety instructions in this chapter will operate and maintain this machine.
- Clearly defining the responsibility of the operating and service personnel as required in the operating manual.
- Checking the personal protective equipment of the operating and service personnel.
- Ensuring a technically safe state of the machine.
- Ensuring that servicing and maintenance are carried out according to the maintenance schedule.
- Notifying the manufacturer of any accident involving the machine that results in serious injury or substantial material damage.
- Decommissioning the machine immediately if defects arise that affect its operational safety.

Areas of responsibility of the operating and service personnel:

- Wearing the required personal protective equipment.
- Halting operation immediately in the event of faults.
- Reporting any changes which affect operational safety.
- Keeping the machine clean.
- Check the function of the EMERGENCY STOP control devices before starting work.

3.6 Personnel requirements

The operating and service personnel must

- be able to read and understand one of the languages on the command menu (e.g., German, English, French, Spanish, Italian).
- Be physically and mentally suited.
- Be qualified in the use of the machine by means of thorough training.
- Have read and understood the operating instructions/service manual.
- Be over the age of 16.
- Have knowledge of first aid and the use of fire extinguishers.

3.7 Personal protective equipment

The safety equipment required for operating the machine is dependent on the following factors:

- Module and tool system used
- Processing material used

When operating the machine or carrying out maintenance or servicing work, wear tight fitting clothing and appropriate personal protective equipment.



Warning:

Risk of injury from being caught or trapped in moving machine parts.

- Do not wear loose clothing, scarves, open jackets or open shirt sleeves.
- Remove all jewelry before starting maintenance and servicing work.

Personal protective equipment comprises of:

- Work clothes (service personnel),
- protective goggles (operating and service personnel):
 - To provide protection from particles during machining
 - To protect the eyes from dangerous radiation
 - To protect the eyes from chemicals
- Protective gloves where injury is possible due to:
 - burns
 - sharp or pointed objects.
- Chemical-resistant protective gloves where injury is possible due to:
 - chemicals (cleaning agents)
- Breathing protection when working with poisonous substances
- Hearing protection if the continuous sound pressure level is above 80 dB



Note:

You are personally responsible for:

- wearing the required personal protective equipment
- regular cleaning and maintenance of personal protective equipment;
- replacing damaged and unusable items of protective equipment promptly

3.8 Rules and occupational safety

- Operation of the machine is always subject to local regulations regarding work safety and accident prevention.
- Make sure that there is adequate lighting during operation.
- Check protective devices every time before starting the machine.
- If a hazardous situation arises, activate an EMERGENCY STOP control device to shut down the machine.
- You are not permitted to make unauthorised modifications or changes to the machine which might affect the system's safety. Accessories or spare parts made by other manufacturers may only be used with the machine with the written approval of the manufacturer.
- Only service technicians authorized by the manufacturer are permitted to install, commission, maintain and repair the machine.
- Before carrying out any maintenance, repair and modification work:
 - Switch off the machine using the main switch and secure it with a padlock.
 - Prevent the machine being switched on inadvertently by removing the mains supply cables to the power box (several mains connections available!).

3.9 Conduct in the event of malfunctions

As a matter of principle, all troubleshooting work or inspections on the machine should only be carried out when it is switched off.

The following must never be bypassed or rendered ineffective:

- Light barriers on beams
- Monitoring sensors
- Safety and control switches of the machine

If malfunctions cannot be remedied by the operating personnel using simple means, inform the responsible service center!

3.10 Danger areas

3.10.1 General danger area

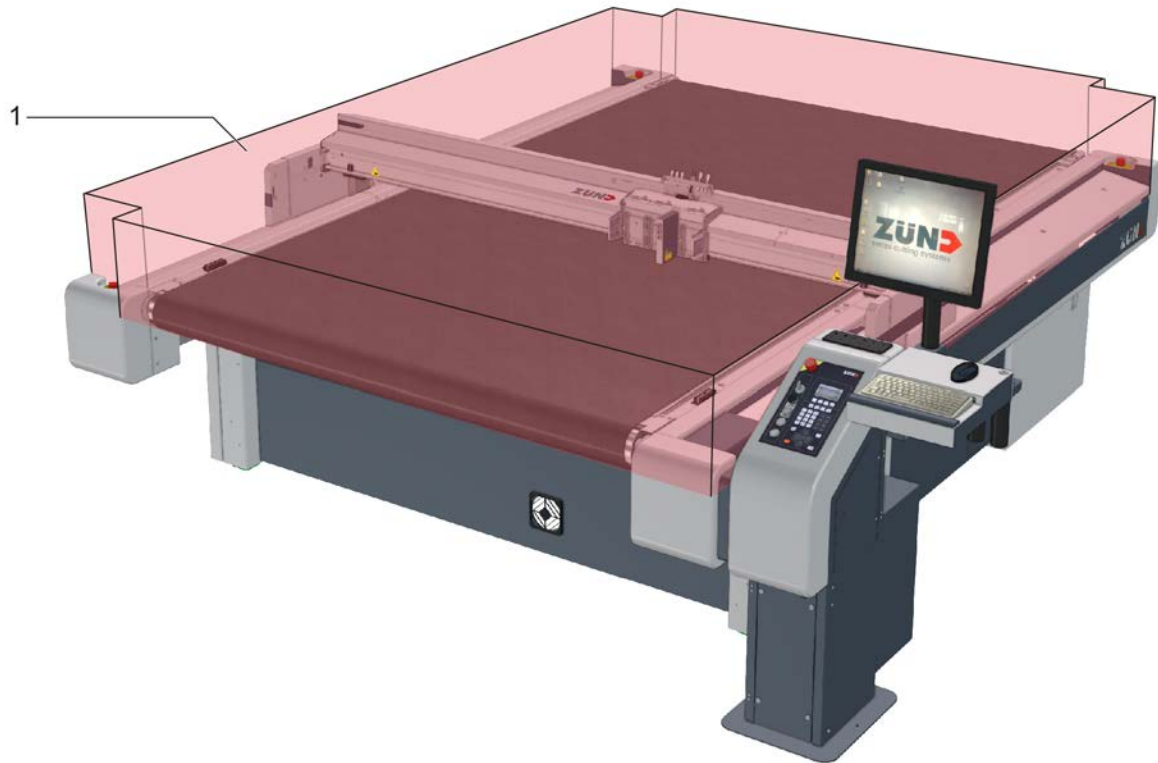

1 Danger area

The danger area is restricted to the working area or the active area of the drive system. Never reach into this work area during processing.

3.10.2 Danger area on the module carriage

**Caution:**

Risk of injury on the module carriage!

The danger area on the module carriage is not secured by safety devices.

- Do not reach into the danger area during manual initialization.
- Secure the danger area on the module carriage with protective slot plates.

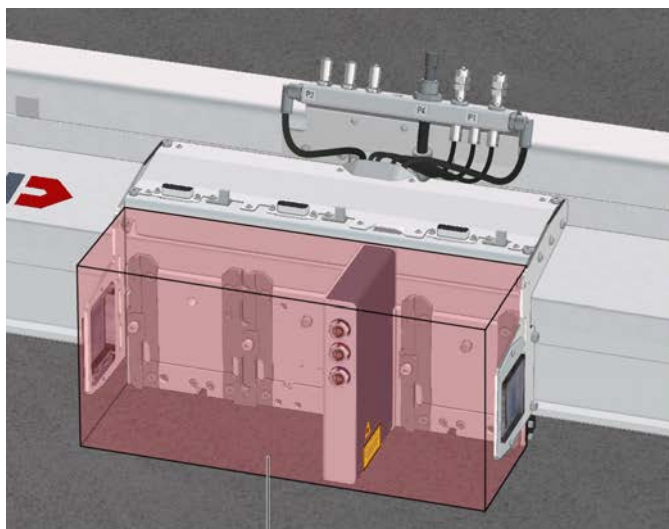

1

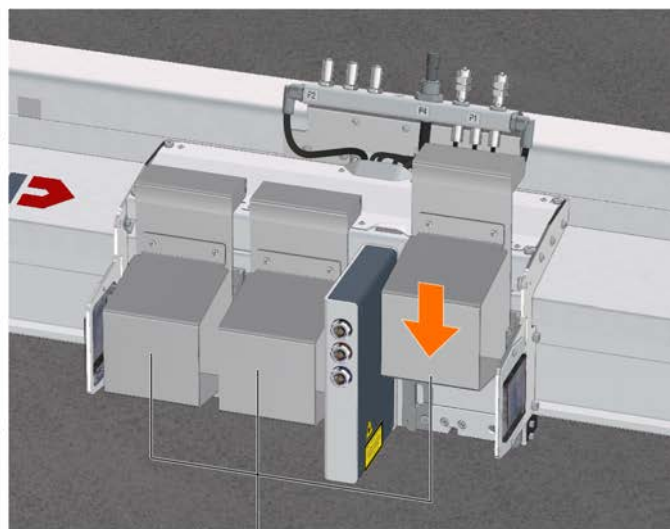

2

- 1 Danger area
- 2 Protective slot plate

Plug a protective plate onto every empty module slot!

3.10.3 Danger area during initialization



Caution:

Risk of injury during manual initialization of the tool!

The front safety devices are not active during manual initialization.

- Do not reach into the danger area during manual initialization
- For initialization, use the Integrated Tool Initialization (ITI) if the tool allows it (for more information, see [Integrated Tool Initialization - ITI](#) on page 122 as well as the corresponding tools operating manual).

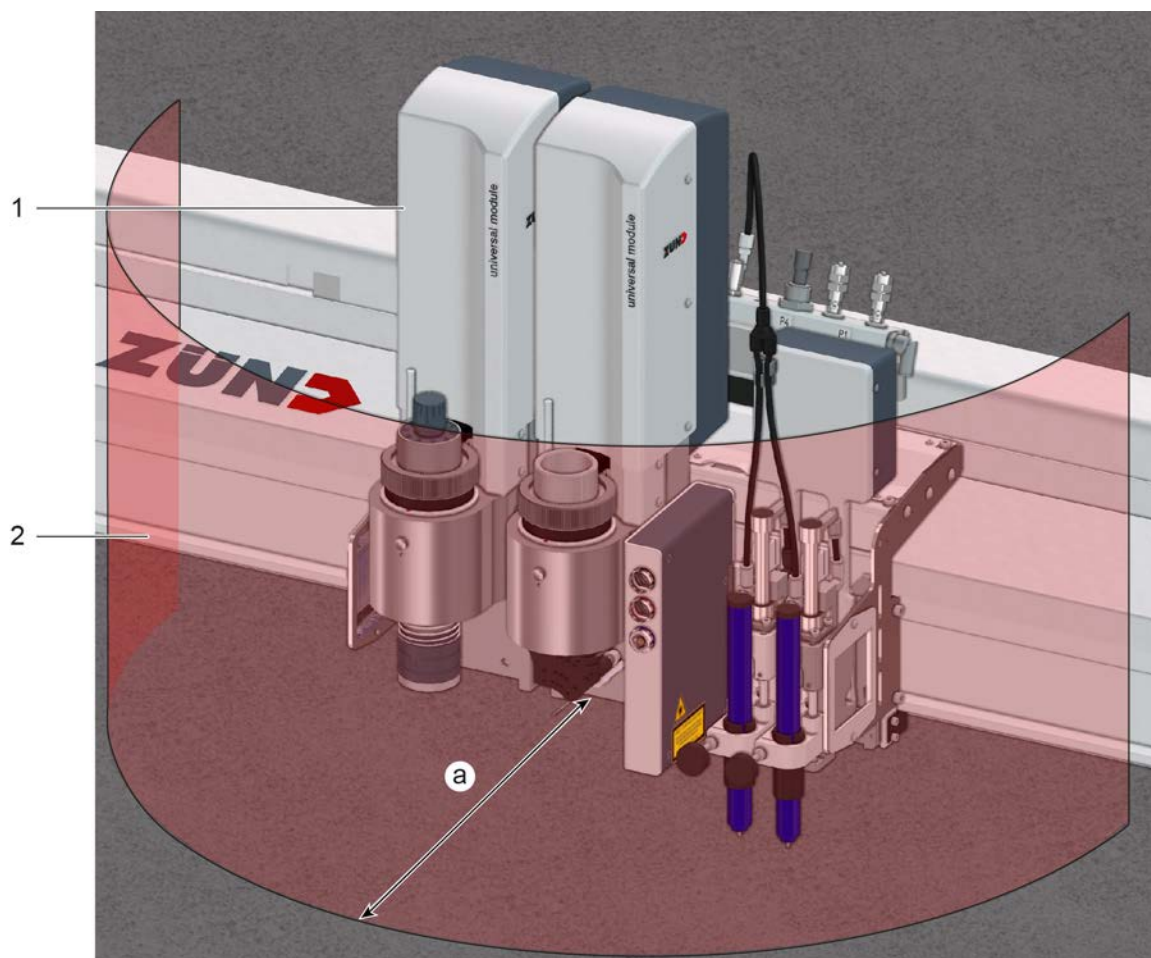

1 Module (e.g., UM)

2 Danger area

A Safety distance during initialization (25 cm)

The safety distance (a) for operating personnel during manual initialization is **25 cm**. Do not reach into the marked danger area during the initialization phase!

3.10.4 Danger area during cleaning

**Caution:**

Risk of injury when cleaning the machine!

Blades, router bits and punching inserts have very sharp edges which are sometimes hidden by moving equipment (spring-loaded gliding disc).



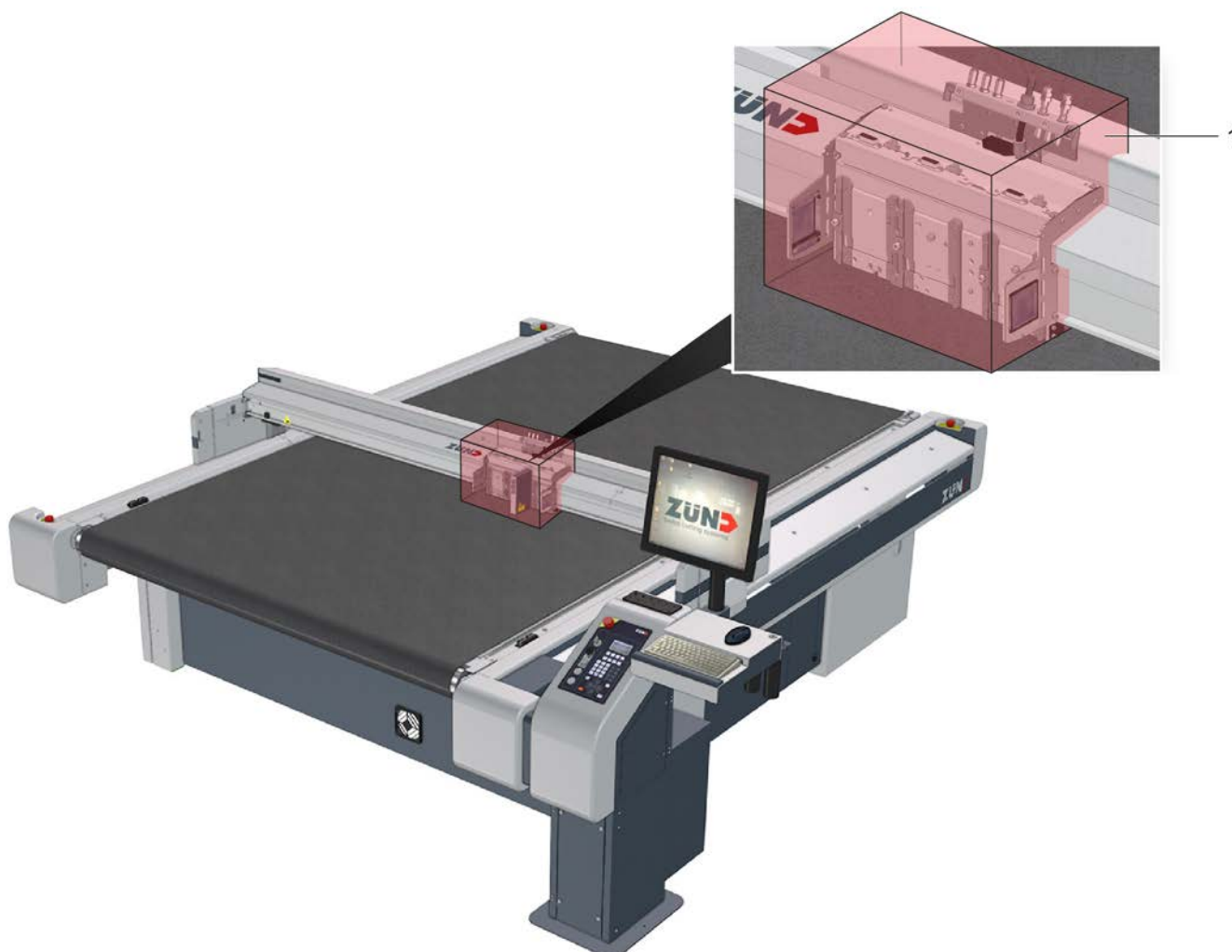

- Before starting to clean, remove all modules and tools from the module carriage.
- Switch off the machine with the main switch and secure it against unauthorised switch-on using a padlock.
- Disconnect the machine from the mains.
- While cleaning work is being performed, attach a sign that says "DO NOT SWITCH ON" and which is prominently displayed on the main control panel of the machine.



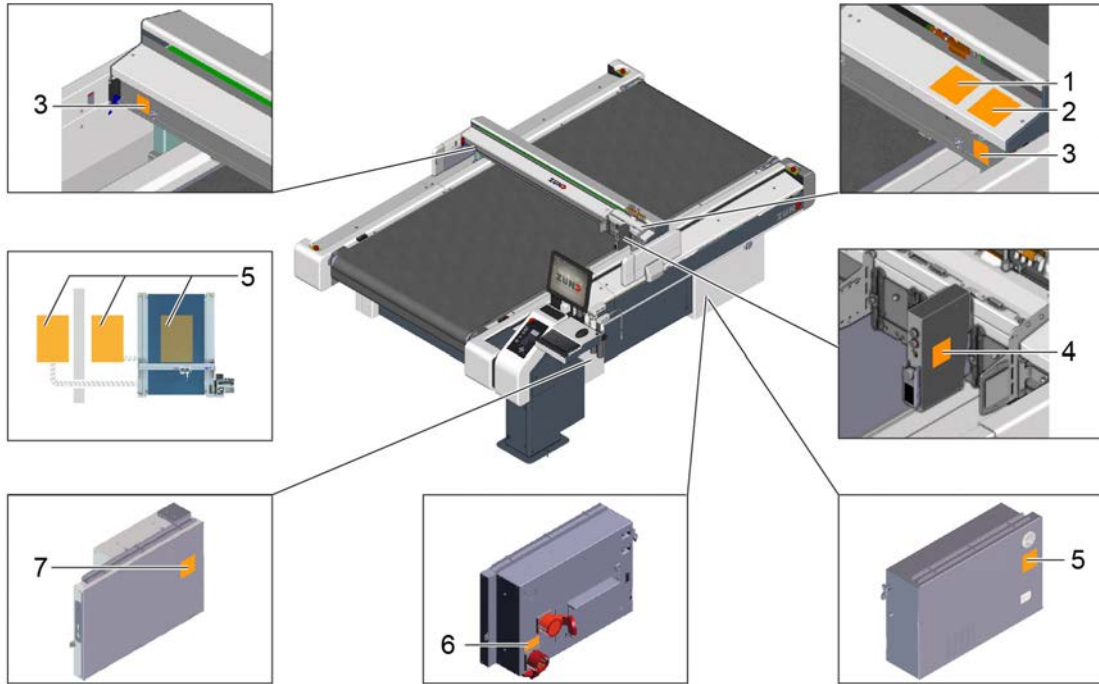











1 Danger area

3.11 Warnings on the product



No.	Description	Variant 1 (CE)	Variant 2 (ANSI)				
1	Mandatory sign: Wear protective gloves	 Art. no.: 5800412 (50 mm)	 <table border="1" style="display: inline-table; vertical-align: middle;"> <tr> <td style="background-color: yellow;">CAUTION</td> </tr> <tr> <td>protective gloves required</td> </tr> <tr> <td style="background-color: yellow;">PRUDENCE</td> </tr> <tr> <td>gants de protection obligatoires</td> </tr> </table> Art. no.: 5801106 (65 mm)	CAUTION	protective gloves required	PRUDENCE	gants de protection obligatoires
CAUTION							
protective gloves required							
PRUDENCE							
gants de protection obligatoires							
2	Mandatory sign: Wear eye protection	 Art. no.: 5800467 (50 mm)	 <table border="1" style="display: inline-table; vertical-align: middle;"> <tr> <td style="background-color: yellow;">CAUTION</td> </tr> <tr> <td>Eye protection required</td> </tr> <tr> <td style="background-color: yellow;">PRUDENCE</td> </tr> <tr> <td>Protection obligatoire des yeux</td> </tr> </table> Art. no.: 5801058 (65 mm)	CAUTION	Eye protection required	PRUDENCE	Protection obligatoire des yeux
CAUTION							
Eye protection required							
PRUDENCE							
Protection obligatoire des yeux							

No.	Description	Variant 1 (CE)	Variant 2 (ANSI)
3	Warning sign: Hand injuries due to crushing	 Art. no.: 5800342 (50 mm)	 WARNING Crush hazard Keep hands clear of moving parts AVERTISSEMENT Risque d'écrasement Tenir les mains à l'écart des pièces mobiles Art. no.: 5801059 (65 mm)
4	Warning sign: Laser beam	 Art. no.: 5811418 (50 mm)  Art. no.: 5800344 (25 mm)	 Art. no.: 5811418 (50 mm)  WARNING Laser radiation Do not stare into beam Laser class II AVERTISSEMENT RAYONNEMENT LASER NE PAS REGARDER EN DIRECTION DU RAYON Laser de classe II Art. no.: 5801062 (40 mm)
5	Warning sign: Electrical hazard	 Art. no.: 5801338 (50 mm)	 WARNING Hazardous power inside Disconnect all power supplies before servicing Service by trained personnel only AVERTISSEMENT Tension dangereuse à l'intérieur Débranchez toutes les alimentations électriques avant d'effectuer la maintenance Maintenance réservée au personnel compétent uniquement  Art. no.: 5802331 (95 mm)
6	Warning sign: Electrical hazard	 Art. no.: 5200367 (110 mm)	 Art. no.: 5200367 (110 mm)

No.	Description	Variant 1 (CE)	Variant 2 (ANSI)
7	Warning sign: Electrical hazard	 <p data-bbox="647 432 863 495">Art. no.: 5801338 (50 mm)</p>	 <p data-bbox="1050 450 1265 512">Art. no.: 5802362 (95 mm)</p>

3.12 Protective devices

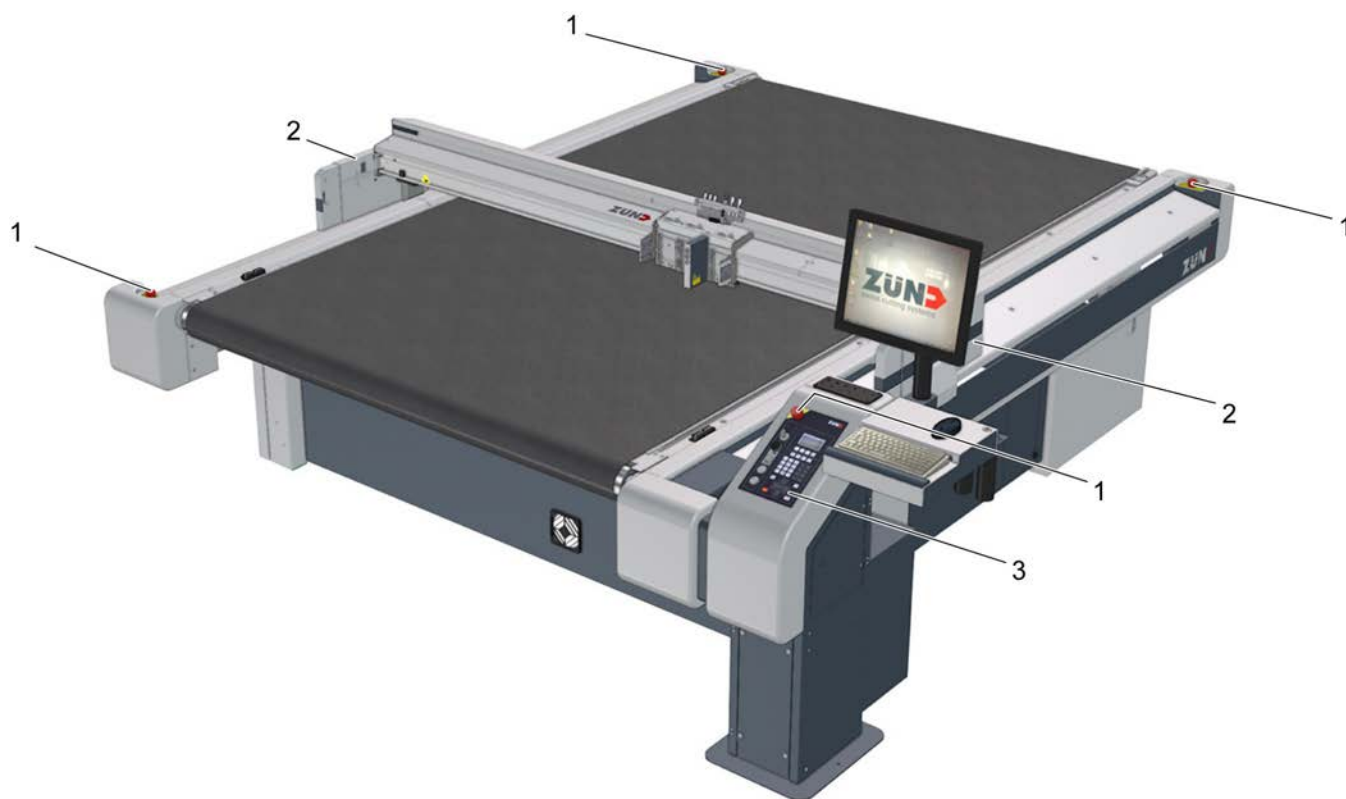

- 1 EMERGENCY STOP control devices
- 2 Safety device (protective trip switch, light barriers)
- 3 Control panel

3.12.1 Safety device



Caution:

The beam may cause serious injuries in case of a collision.

Note that the high level of kinetic energy of the drive results in a significant braking distance. Light barriers and protective trip switches are no guarantee against injuries!

The safety device consists of protective trip switches and light barriers on the beam ends. The machine is stopped automatically if the light barriers or protective trip switches detect an obstacle.

Effects for the cutter

- The drive motors (beams, module carriage) are slowed to a standstill.
 - The Z-axis remains in the position where it is located when the safety device is triggered (e.g. lower position).
 - The cutter switches to STOPPED mode.
 - Safety-relevant units (modules, tools, auxiliary drive, etc.) are stopped or switched off.
- Safety-relevant units (modules, tools, etc.) are stopped or switched off.

- Units that are not safety-relevant or important for the operation of the machine, such as the operating unit, remain switched on.
- An error message is displayed.
- A warning tone sounds.

Effects on the options connected to the cutter

- Synchronised movements are stopped.
- Units that are not safety-relevant or important for the operation of the machine remain switched on.

Recommissioning

- Restore operational safety.
- Free the protective trip switches or light barriers of obstacles.
- Acknowledge the error message on the control panel.

Tip:

If the Z-axis is in the upper or lower position when the safety device is triggered, it is now raised to the park position.

3.12.2 Control panel

Malfunctions are shown on the LCD display.

An acoustic signal sounds in the event of an error or light barrier interruption or activation of an EMERGENCY STOP control device.

3.12.3 EMERGENCY STOP control devices

Activating an EMERGENCY STOP control device triggers a machine standstill in the event of an emergency.



Danger:

Risk of injury due to inaccessible EMERGENCY STOP control device!

Machines with inaccessible EMERGENCY STOP control devices are not safe for operation. The machine cannot be stopped promptly in hazardous situations.

- Ensure that all EMERGENCY STOP control devices are easy to access and not hidden.



Note:

Risk of damage to the cutter by activating EMERGENCY STOP control devices.

Do not use EMERGENCY STOP control devices to switch off the machine under normal circumstances.



Note:

To unlock an activated EMERGENCY STOP control device after restoring operational safety, turn the switch clockwise (see [Reset EMERGENCY STOP control devices](#) on page 88 [Reset EMERGENCY STOP control devices](#) [Reset EMERGENCY STOP control devices](#) [Reset EMERGENCY STOP control devices](#)).

3.12.4 Shutdown in an emergency

An emergency shutdown allows the machine to be stopped quickly in case of emergency.

Effects for the cutter

- The drive motors (beams, module carriers) are braked to a standstill and are then disconnected from the energy supply.
- The drive axes are free and can be moved by hand.
- The cutter switches to STOPPED mode.
- Safety-related units (modules, tools, auxiliary drive...) are isolated from the energy supply. Safety-related units (modules, tools...) are disconnected from the energy supply.
- Units that are not safety-relevant or important for the operation of the machine, such as the operating unit, remain switched on.
- An error message is displayed.
- A warning tone sounds.
- The EMERGENCY STOP control device remains locked in the off position.

Effects on the options connected to the cutter

- Synchronised movements are stopped.
- Units that are not safety-relevant or important for the operation of the machine remain switched on.

3.12.5 Shutdown in the event of overload

The machine automatically shuts down if an axis (X, Y, T, Z) becomes blocked or overloaded.

Effects for the cutter

- The drive motors (beams, module carriers) are braked to a standstill and are then disconnected from the energy supply.
- The drive axes are free and can be moved by hand.
- Safety-relevant units (modules, tools, auxiliary drive, etc.) are stopped or switched off. Safety-relevant units (modules, tools, etc.) are stopped or switched off.
- Units that are not safety-relevant or important for the operation of the machine, such as the operating unit, remain switched on.
- The cutter switches to the STOPPED operating mode
- An error message is displayed.
- A warning tone sounds.

Effects on the options connected to the cutter

- Synchronised movements are stopped.
- Units that are not safety-relevant or important for the operation of the machine remain switched on.

3.12.6 Light curtain (optional)

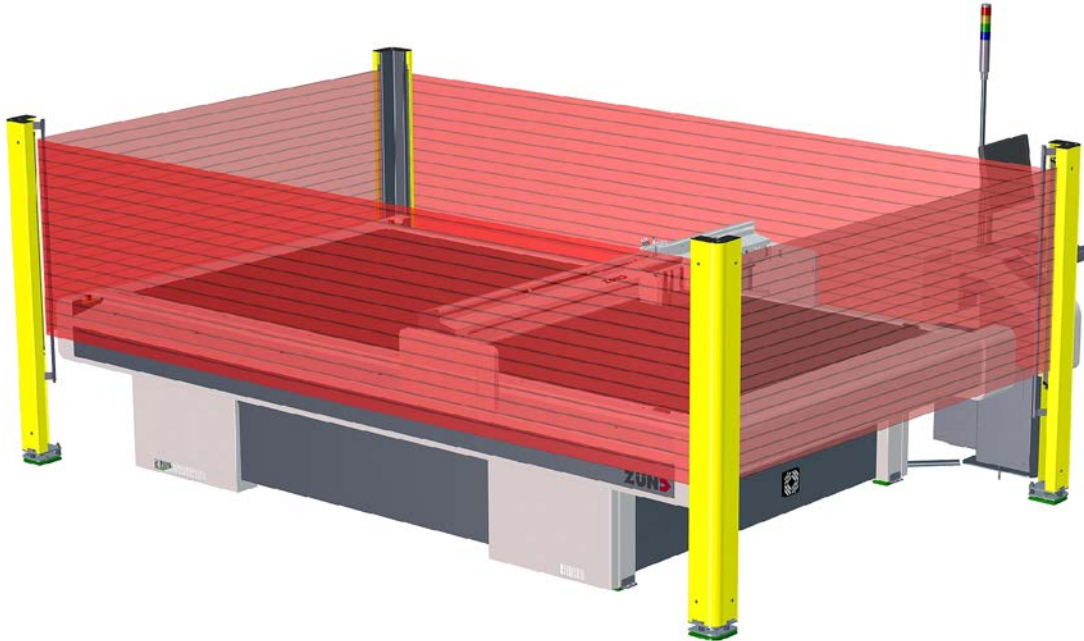

If the light curtain is interrupted by an object or person while an object is moving, the machine automatically comes to a standstill.

Effects for the cutter

- The drive motors (beams, module carriage) are slowed to a standstill.
- The Z-axis remains in the position where it is located when the safety device is triggered (e.g. lower position).
- The cutter switches to STOPPED mode.
- Safety-relevant units (modules, tools, auxiliary drive, etc.) are stopped or switched off.
- Units that are not safety-relevant or important for the operation of the machine, such as the operating unit, remain switched on.
- An error message is displayed.
- A warning tone sounds.

Effects on the options connected to the cutter

- Synchronised movements are stopped.
- Units that are not safety-relevant or important for the operation of the machine remain switched on.

Recommissioning

- Restore safe operating conditions.
- Ensure that the light curtain is not interrupted.
- Confirm the error message.

Tip:

If the Z-axis is in the upper or lower position when the safety device is triggered, it is now raised to the park position.

3.13 Mechanical hazards

3.13.1 Collection, retraction



Caution:

Risk of injury from entanglement, getting caught and being pulled in!
The machine and the tool system has moving parts.

Possible consequences

- Bruises, crushing, lacerations to fingers or hands
- Bruising to the head and arms
- Pulling out of hair
- Damage to clothing
- Damage to machine

Precautions during initialization and operation in ONLINE mode:

- Do not touch modules and beams
- Do not reach into the working and moving area
- Do not touch the table plate or the material lying on it
- Do not place hands on side covers
- Do not lean with the torso on the work surface
- Avoid untied long hair and loose clothing and ties

These precautions specifically apply if the cutter can be switched into ONLINE operating mode by the CAD/CAM system.

3.13.2 Hazards from foreign bodies



Caution:

Injury risk due to objects being ejected!

Foreign bodies on the table plate are collected by the beam or the module/tool/module carriage and pushed away!

Possible consequences

- Facial injuries and others
- Damage to the machine

Precautionary measures during initialization and operation in ONLINE/OFFLINE mode:

- Do not place any materials, tools, or other objects on the table plate or the side covers.
- Before operation, check whether there are any objects on the table plate or the side covers.

3.13.3 Cut and puncture injuries



Caution:

Injury risk from sharp objects!

Blades, router bits and punching inserts have very sharp edges which are sometimes hidden by moving equipment (spring-loaded gliding disc).

Possible consequences

- Cutting and stabbing injuries to the hands and arms

Precautionary measures

- Change the tool inserts with extreme caution.
- Do not enter the working area during initialization and during operation in ONLINE mode.

3.14 Risk of burns



Warning:

Risk of injury from burning!

Certain materials (metals) or tools (blade, router) reach very high temperatures during processing.

Possible consequences

- Burning injuries to the limbs

Precautionary measures

- Allow workpieces to cool down before removal
- Wear suitable protective gloves when removing freshly processed workpieces
- Allow tools (router, blade) to cool before removing them

3.15 Electrical hazard



Warning:

The machine is operated with a mains voltage of 400/208 V and a mains frequency of 50/60 Hz.

Possible consequences

- Risk of death or injury from electric shock.

Precautionary measures

- Only trained service personnel and authorized service technicians are allowed to open power boxes, switch boxes and electronics units.
- Ensure that the mains cables are protected against mechanical loads and are laid so that they are free from strain.
- Ensure damaged cables are replaced immediately.

3.16 Risks arising from the emission of toxic dust



Warning:

Risk of poisoning from the emission of toxic dust!

Processing certain materials can lead to the creation of harmful toxic dust.

- Obtain information about the toxicity of the material to be processed from the manufacturer.
- Use a suitable extraction unit or implement other appropriate measures accordingly.

The operator of the system is responsible for making sure that all national regulations concerning the maximum permissible dust concentrations in the workplace are complied with. When handling hazardous types of dust, all local safety regulations as well as the manufacturer's instructions must be observed. When routing or processing hazardous materials, always use dust extractors with special dust filters designed for the purpose. As an optional accessory, Zünd offers extraction systems that comply with the following regulations:

- the extraction of hazardous dusts with MAK values up to 0.1 mg/m^3 and wood dusts conforming to dust class M
- the extraction of dusts conforming to dust class H

3.17 Risks arising from the processing of toxic materials/materials hazardous to health



Warning:

Risk of poisoning from emissions when processing toxic materials!

Processing such a wide variety of materials can lead to toxic emissions (gases, dust etc.) that are hazardous to your health.

- Never process toxic materials/materials hazardous to health!
- Obtain information from the manufacturer of the material to be processed about its toxicity.

Observe the following guidelines when handling toxic/hazardous materials:

- The operator of the system is responsible for determining which processing materials are toxic/hazardous.
- It is forbidden to process toxic materials on Zünd cutters without appropriate additional safety measures!
- The operator of the system is responsible for installing appropriate additional safety measures!

3.18 Environmental hazards



Warning:

Processing residues, operating materials, cleaning agents etc. can cause damage and pollute the environment if they enter the soil, waterbodies or the sewage system.

Explanation of the hazard label



Hazard label for substances that are harmful to the environment



Safety regulations and protective measures

- Dispose of waste materials in accordance with current national environmental protection regulations. In case of doubt, check on the appropriate disposal methods with your local collection point or recycling center.
- Collect different chemicals in separate containers.

3.19 Handling and storage of chemicals



Warning:

Cleaning agents and operating materials can cause skin irritation and can therefore be hazardous to your health if handled carelessly.

Always wear your personal protective gear (protective gloves, goggles, mouth guard etc.) when handling chemicals.

Explanation of the hazard label



Hazard label for very toxic or toxic substances



Hazard label for hazardous substances or irritant materials



Hazard label for irritating substances



Note:

Chemicals classified as irritants are used to operate and clean this machine (cleaning agents, operating fluids). Safety datasheets for the substances in question can be downloaded from the Zünd homepage (www.zund.com).

Safe handling of chemicals

Important:

Dispose of chemicals in accordance with national regulations. Follow the manufacturer's instructions (MSDS).

- Store chemicals in tightly closed containers in a cool, dry place (between 5 °C and 30 °C).
- Protect the containers from heat and direct sunlight.
- Provide good ventilation, including at floor level.
- Store chemicals in accordance with local regulations.
- Keep containers tightly closed.
- Use chemicals as intended only.

3.20 Risk of fire and explosion



Warning:

There is a risk of fire when routing and cutting flammable materials
Terminate the routing/cutting and leave the tool to cool off in case of

- smoke emission.
- Discolorations on the router/blade which point to increased heat development



Warning:

Risk of dust explosions

Flying sparks or electrostatic charges result in the risk of dust explosions during the extraction of different materials.

- Find information about the risk of explosion when processing the type of material that you are using and, if necessary, do not process it.
- If necessary, adjust the extraction to the required regulations.

Observe the following safety rules and countermeasures



- Find out the locations where fire extinguishers are kept and familiarize yourself with their use and operation. The adjacent sign indicates the location of a fire extinguisher.
- Do not use inflammable cleaning agents to clean the cutter.
- Store all processing materials in the proper manner in accordance with local guidelines.

Classes of fire

Refer to the following table to find out which type of fire extinguisher is used for each fire class:



Solid materials, mainly organic in nature; e.g. wood, paper, textiles, etc.



Liquid and liquefiable substances; e.g. gasoline, oils, grease, paints etc.



Combustible gases: e.g. methane, propane, etc.

Behaviour in the event of a fire

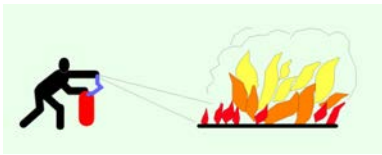

- Turn off the machine using the main switch
- Assess the situation: If there is danger, leave the area immediately and call the fire department. Only try to extinguish the fire if your personal safety is not at risk.
- Remove a suitable fire extinguisher (A, B, C) from its bracket and prepare it for use.
- Locate the source of the fire. Attack the fire with repeated short bursts from the extinguisher. Always spray the extinguishing agent from underneath into the source of the fire. In other words, always aim at the burning material and not at the flames.
- After using the fire extinguisher, do not return it to its usual place but have it refilled immediately.

3.21 Danger from laser beam

The optional ICC camera with laser pointer, the laser pointer, and the light curtain use a visible laser beam. The laser beam is considered to be harmless to the human eye in case of short-term exposure (<0.25 s) (class 2 laser).

The ICC camera with laser pointer or the laser pointer are switched on together with the cutter. By design, the laser beam is directed down onto the material.

In the case of the light curtain, the laser beam is switched off during normal operation. The laser beam is only needed to adjust the light curtain and must be switched on manually.

Safety instructions

- Do not look into laser beam.
- If a laser beam hits your eye, close your eyes or turn away immediately.
- Keep in mind that certain medications or consuming alcohol may cause a delayed blinking reflex.

3.22 Safety instructions for the operating personnel

This instruction manual cannot cover all possible situations and potential hazards.

It is therefore particularly important that operating personnel

- have been thoroughly trained and are aware of and able to correctly assess the hazards that can arise from the machine.
- Knows all protective devices on the machine.
- Request information from the manufacturer without delay if an undocumented, hazardous situation arises in connection with the machine.

In addition to these safety instructions, you must also observe the situation-related safety notes in the chapters "Controls and operation" and "Maintenance and cleaning".

3.23 Safety precautions for service personnel

The reliability, readiness and service life of the machine greatly depend on you carrying out your work in a conscientious manner.



Note:

Specialist knowledge and expertise are required to service and maintain the machine. The manufacturer provides this knowledge through training courses which are specially tailored for service personnel. Only personnel with Zünd certification are permitted to carry out service work on Zünd cutters.

3.24 Disposal

Information about proper disposal



The symbol has the following functions:

- Marking substances that are toxic and harmful to the environment
- Instructions for disposal of harmful substances
- Warning against disposal with domestic waste or environmental pollution caused by hazardous substances and objects contaminated with such substances

Measures for disposal

Zünd cutters correspond with the requirements of the German Electrical and Electronic Equipment Act and generally do not contain any poisonous substances or consumables.

Contact Zünd customer services or your service partner before you dispose of your cutter.

Dispose of cutting waste in accordance with current national environmental protection regulations.

In case of doubt, check the appropriate disposal methods with your local collection point or recycling center.

4 Controls and operation

This chapter familiarizes you with the controls, guides you through the operational procedures and describes the following operating steps:

- Daily commissioning
- Operation of the main components
- Detailed information on the operation of the machine
- Safe switch-off of the machine

4.1 Safe working practices



Danger:

Operating errors or negligence can put human lives at risk as well as causing serious damage to the machine!

The machine is fitted with safety devices to minimise risk. However, these safety devices cannot guard against damage as a result of operating errors or negligent working practices.

Observe the safety requirements from Chapter [Safety](#) and the situational safety requirements of the appropriate working step.

Operator personnel are responsible for the safe use of the machine!

4.2 Controls

4.2.1 Overview



- 1 EMERGENCY STOP control devices
- 2 Control panel
- 3 Maintenance units (dependent on cutter configuration)

4.2.2 Control panel

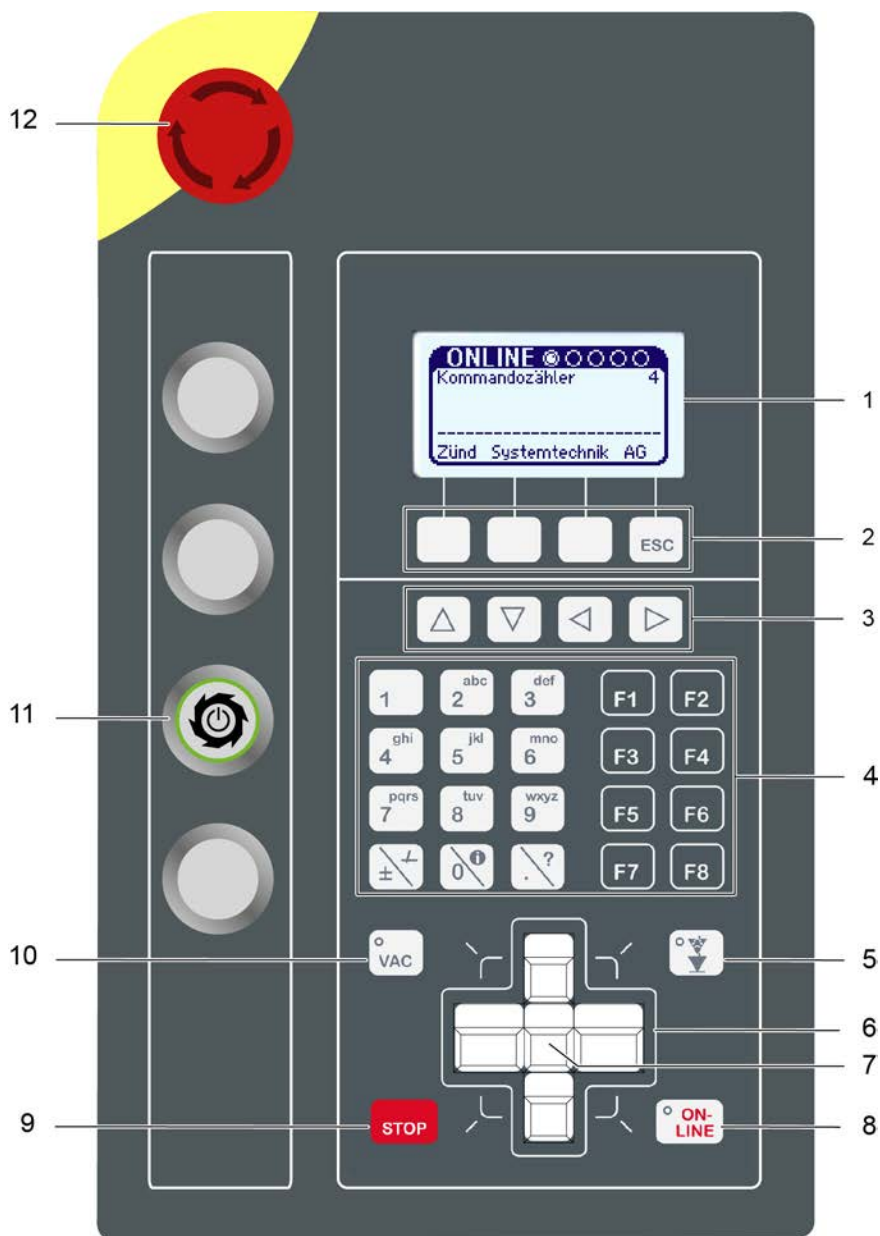

- | | | | |
|---|--------------------------------|----|---|
| 1 | Display | 7 | SHIFT key |
| 2 | Soft keys | 8 | ONLINE key |
| 3 | Navigation keys | 9 | STOP key |
| 4 | Number block and function keys | 10 | VAC (vacuum) key |
| 5 | Tool up/down key | 11 | Router release switch/button (optional) |
| 6 | Travel keys | 12 | EMERGENCY STOP control device |

4.2.3 EMERGENCY STOP control devices

Activating an EMERGENCY STOP control device triggers a machine standstill in the event of an emergency.

The cutter is fitted with four EMERGENCY STOP control devices as standard. They are located as follows:

- 1 x on control panel
- 3 x on the side support covers

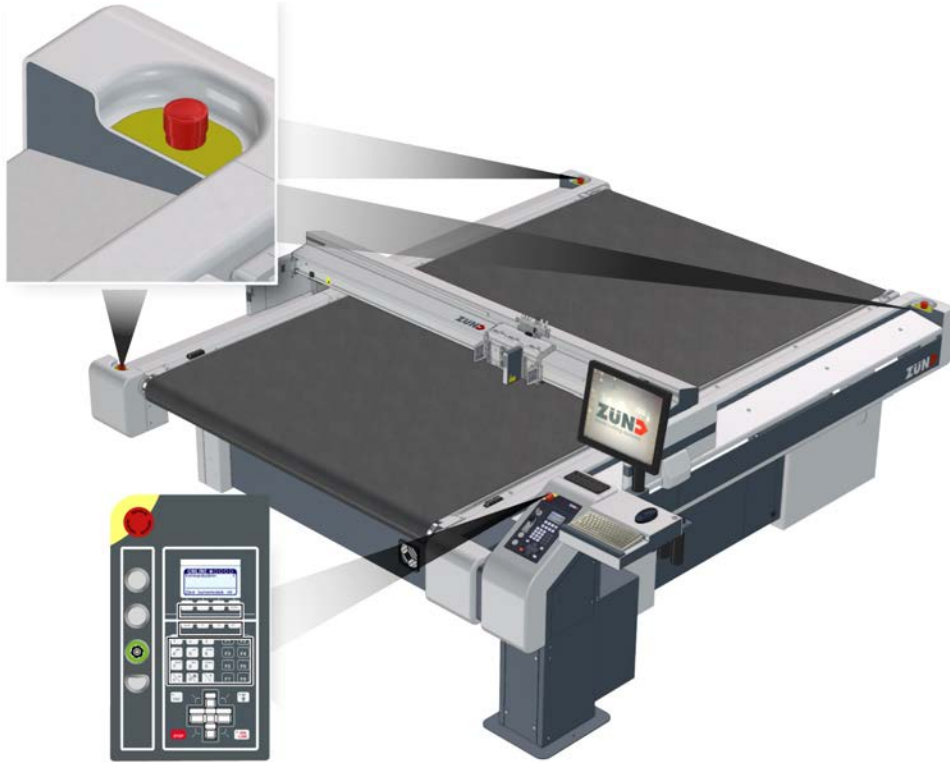

Danger:

Risk of injury due to inaccessible EMERGENCY STOP control device!

Machines with inaccessible EMERGENCY STOP control devices are not safe for operation. The machine cannot be stopped promptly in hazardous situations.

- Ensure that all EMERGENCY STOP control devices are easy to access and not hidden.



Note:

Risk of damage to the cutter by activating EMERGENCY STOP control devices.

Do not use EMERGENCY STOP control devices to switch off the machine under normal circumstances.



Note:

The activated EMERGENCY STOP control device remains locked in the off position.

To unlock an activated EMERGENCY STOP control device after restoring operational safety, turn the switch clockwise ([Reset EMERGENCY STOP control devices](#) on page 88)

4.2.4 Maintenance unit

The maintenance unit adjusts the air pressure to switch the vacuum elements/various modules and options. Depending on cutter configuration, a maintenance unit consists of various elements.

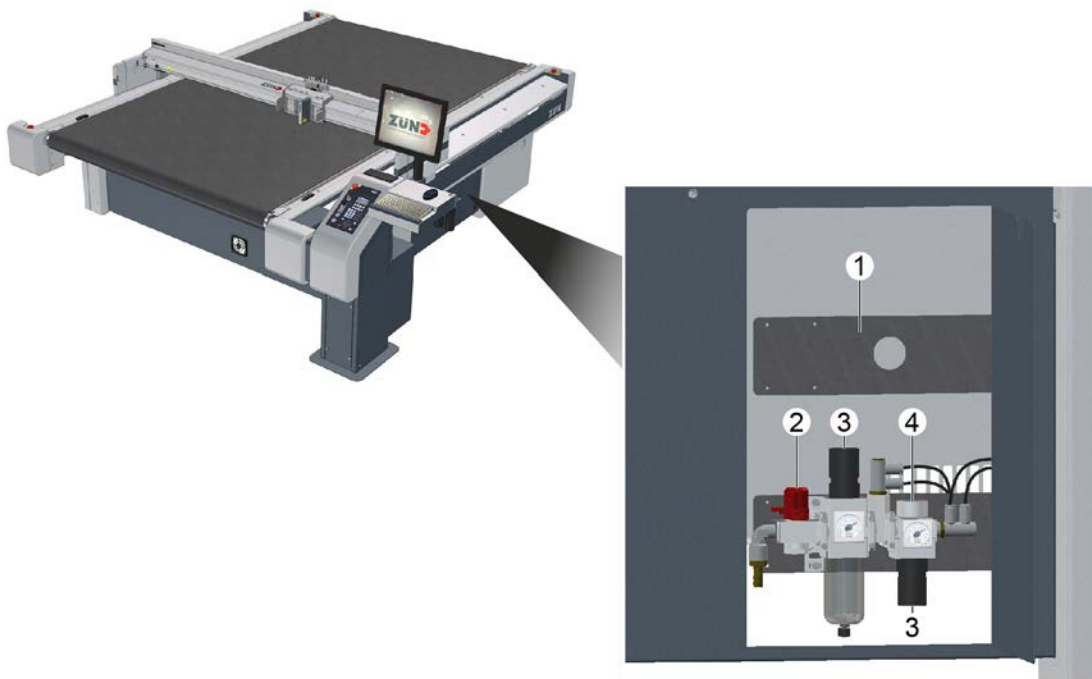

- 1 Fixing bracket for an additional, optional maintenance unit
- 2 Stopcock
- 3 Water separator
- 4 Air pressure setting

The maintenance unit is preset and adjusted.

Check the air pressure setting at regular intervals. For details about the setting values, see [Compressed air supply](#) on page 35.

4.2.5 Interfaces

The machine has data exchange interfaces. These are attached to the electronics unit.



Note:

Risk of electric short-circuit!

For machines with optional carbon dust protection, all unused interfaces must be covered.

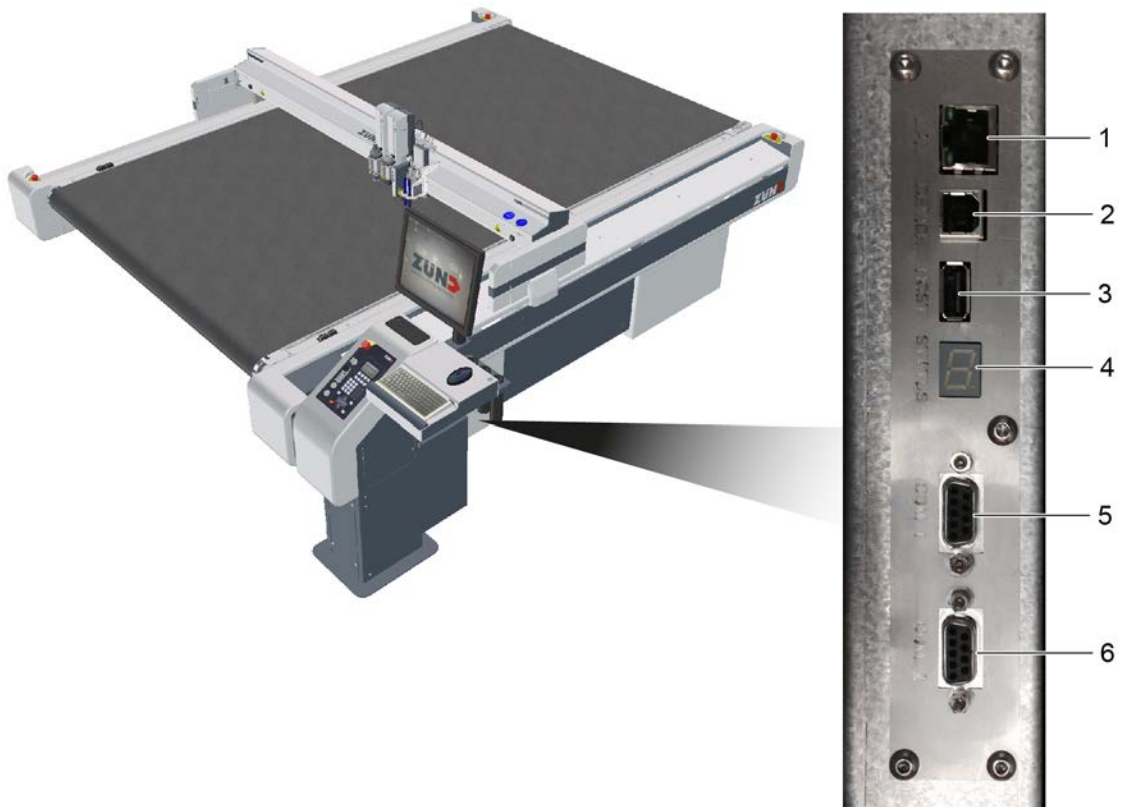





- 1 LAN
- 2 not used
- 3 USB (host) - not used
- 4 Status and error display
- 5 COM 1
- 6 COM 2

4.3 Menu navigation



4.3.1 Navigation keys



Functions in the cutter menu

Key	
 	Use these keys to navigate through the menu
	<ul style="list-style-type: none"> • If submenus are available, use this key to change to the next menu level • Select setting/function
	Switching from a sub-menu to the previous menu level

Function in the editor

Key	
 	Use these keys to move the cursor to the right or left

4.3.2 Help

Help texts are available for important menu entries. In order to display a help text, mark the required menu and press the  key.

4.3.3 Info menu

Within the menu the Info menu can be activated with the  key. The info menu also works in online dialog and when an error message is displayed.

Tab	Information
Assignment	Information on the module carriage
Module	Information about the module
Position	Specification of the current position of the current tool
Buffer	Information about the memory system
Job	Information about the print job
Status	Display of the user level, the operating mode...

Tab	Information
Function keys	Allocation of the function keys
Communication	Settings such as: interface, port, IP address, mask, MAC address

Switch between tabs with the   key. Scroll up/down within the tab with the   key.





4.3.4 Pop-ups, dialog boxes

Pop-up menus or dialog boxes are displayed for the following actions:

- Error messages (dialog)
- Cutter status display (dialog)
- Menus that are called up using function keys (pop-ups)

The system changes back to the previously active menu when a pop-up or a dialog box is closed.

4.3.5 Layout



Symbol	Description
	Menu
	Blocked menu (user level)
	Command, execute function
	Display of a value

4.4 Menus and functions

The cutter has a multitude of functions. The current menu number and the current menu are displayed in the header.

17183 Configuration	
1. Release time	400 ms
2. Setting time	400 ms



4.4.1 Navigation in the menu

A Scroll through the menu with the navigation keys   and select a sub-menu with .

B To return to the previous menu level, press the  navigation key. To return to the main menu, press ESC.

4.4.2 Selection



- A** Use the   navigation keys to select an entry from the list.
- B** Confirm the selection with **OK** and cancel by pressing **ESC**.

4.4.3 Select commands, functions

Mark the required command with the navigation keys   and select with .

The command can also be activated directly via the menu number. In order to do this, enter the menu number using the numeric keypad (see [Direct selection of menus](#) on page 77).

Important:

Commands are carried out immediately after entry. An exception to this rule are safety-relevant commands (e.g., automatic startup). Confirm the selection with **OK** or cancel with **ESC**.

4.4.4 Direct selection of menus

Each menu and each function is allocated a unique menu number. It is possible to switch between menus by entering the menu number.

Two-figure menu numbers (10, 11...) are displayed lower down. Before entering two-digit menu numbers, press the  key and then enter both digits.

4.4.5 Function keys

The cutter has function keys (F1 - F8) which can be freely allocated to menu functions.

Allocate function keys directly

To change the function keys, at least the [User level](#) on page 79 "Operator" is required.

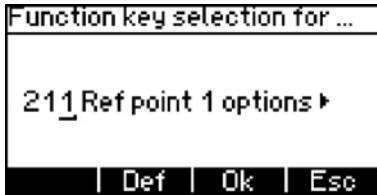

- A Simultaneously press the **SHIFT** key and the function key (F1 - F8) for which you would like to change the function.
- B The function key selection window opens.
- C Enter the menu number of the desired menu entry using the number field.
- D Confirm the selection with **OK** or cancel by pressing **ESC**.

Allocating the function key via the menu

To change the function keys, at least the *User level* on page 79 "Operator" is required.

- A Select the **6-5 Function keys** menu.
- B Enter the numbers **1 - 8** for the respective function key F1 - F8.
- C The function key selection window opens.
- D Enter the menu number of the desired menu entry using the number field.
- E Confirm the selection with **OK** or cancel by pressing **ESC**.

Resetting a function key to the factory settings

To change the function keys, at least the *User level* on page 79 "Operator" is required.

- A Change to the **6-5 Function keys** menu.
- B Enter the numbers **1 - 8** for the respective function key F1 - F8.
- C The function key selection window opens.
- D Press the **DEF** key to load the factory settings.
- E Confirm the selection with **OK** and cancel by pressing **ESC**.

4.4.6 Entering values

- A Select menu (e.g., **1-1-1-2-3 Up Z pos**).
- B Enter the value using the numeric keypad. The current value is overwritten.
- C Check the value and confirm with **OK** or cancel the entry using **ESC**.

4.5 General settings



4.5.1 Setting the language

- A Select **6-1 Language**.
- B Select the required language from the list and confirm.



4.5.2 Switch display lighting on/off

Press **Shift + ESC** to switch the display lighting on/off.

4.5.3 Setting the display contrast

Key	Description
Shift + 	Increase contrast
Shift + 	Reduce contrast

4.5.4 Setting the volume

Key	Description
Shift +  	Increase/decrease the volume

4.5.5 Clear buffer

Clear the data buffer following the termination or processing of a job.

Menu	Description
2-4-1 Clear buffer	All the data stored in the data buffer is deleted. The file may have to be resent.

4.6 User level

Access to menus and functions is blocked depending on the user level. The user levels have a hierarchical structure. This means that the next highest user also has the access rights to the menu functions of the subordinate user.

User level	Description
Users 1 - 3	All menus and functions needed for the operation of the machine are accessible
Operator	Simple, uncomplicated adjustments can be made
Service	Cutter settings that may only be adjusted by authorized service personnel.
Factory	-

4.6.1 Changing user levels

A Change to the **4-2 Password** menu.

B Enter your user code.

Results

The user level is approved and is displayed under **4-1 User level**.

4.6.2 Defining active user level after start-up



Tip:

After start-up, it is not possible to define a user level that is higher than your own as an active user level.

- A** Change to the **4-3 Start user** menu.
- B** Select the desired user.

Results

The selected user level will be active the next time the cutter is started.

4.6.3 Changing the password for user levels 2 and 3



Tip:

The passwords for user levels 2 and 3 can be changed in the Operator user level or higher.

- A** Change to the **4-4 Change password** menu.
- B** Select the user.
- C** Enter the new password for the user.

4.7 Malfunctions

4.7.1 Troubleshooting



Caution:

Risk of injury due to incorrectly remedied faults.

- Ensure that the error on the device is remedied correctly.
- Contact your Zünd partner.

Make note of the following information if you need help from the service department to rectify an error in your cutter:

- The serial number of the machine.
- The error message that is displayed on the operating unit or on the status and error display.
- A description of the circumstances in which the error occurred.

4.7.2 Error localization

Errors can be localized both via the control panel, or, if the control panel is defective, via the [Status and error display](#) on the electronics unit.

4.7.2.1 Error display on the operating unit

The error code is made up of a multi-digit, uniquely allocated combination of numbers and letters. The signal word before the error code indicates how serious the error is.

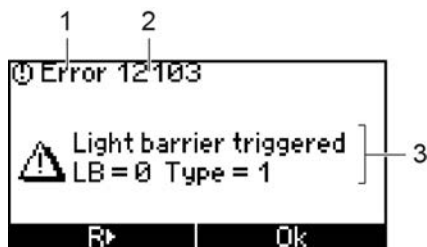

- 1 Signal word
- 2 Error codes
- 3 Error description

Signal word	Error code ends with	Error description
Information	01	Important information for the operating personnel
Warning	02	Notification of possible problems (overheating). Check status, troubleshooting, contact the service department if necessary
Error	03	Errors that are likely to be remedied - contact the service department if necessary
Alarm	04	Serious error - contact the service department

4.7.2.2 Error shown on the status and error display

The error is displayed as a sequence. All superfluous digits of the error code will be omitted in this display!

If several errors occurred one after the other then these are combined together in a group. The error which occurred first is displayed at the start of the group. All other errors follow in order.

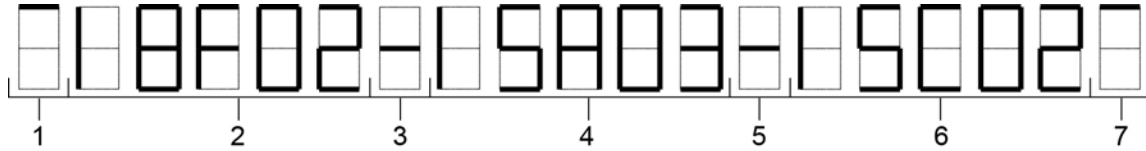





Item	Sequence	Explanation
1	Introduction	The error group is introduced by an introductory sequence
2	Error code 1	Display of the first recorded error code
3	Separator	Display of the error is complete and another error follows
4	Error code 2	Display of the next error code
5	Separator	Display of the error is complete and another error follows
6	Error code 3	Display of the next error code
7	Conclusion	Display of the group has been completed

4.7.3 Error display





If a number of errors have occurred, then the first error of this sequence is always shown on the display of the operating unit.

All errors which have occurred after confirmation of the last error are collected together in a group.

Displaying the last group

All errors of the last group are displayed with SHIFT+     (2nd soft key).

Display list of unresolved errors

While the first error is shown on the display, with SHIFT+     (1st softkey) a list of all unresolved errors can be displayed.

4.7.4 Engaging the automatic circuit breaker



Danger:

Hazardous voltage in the power box

Risk of death or injury from electric shock!

- Do not remove the internal power box cover (power unit) under any circumstances.

- Contact your service partner if you have any problems with the energy supply.



Note:

Risk of damage to the cutter

If an automatic circuit breaker has been triggered, the cause may be an electrical defect in a consumer.

- The list shows the consumers who are protected by the triggered automatic circuit breaker.
- Never start up a damaged cutter.
- Work on the electrical system should only be carried out by qualified electricians.

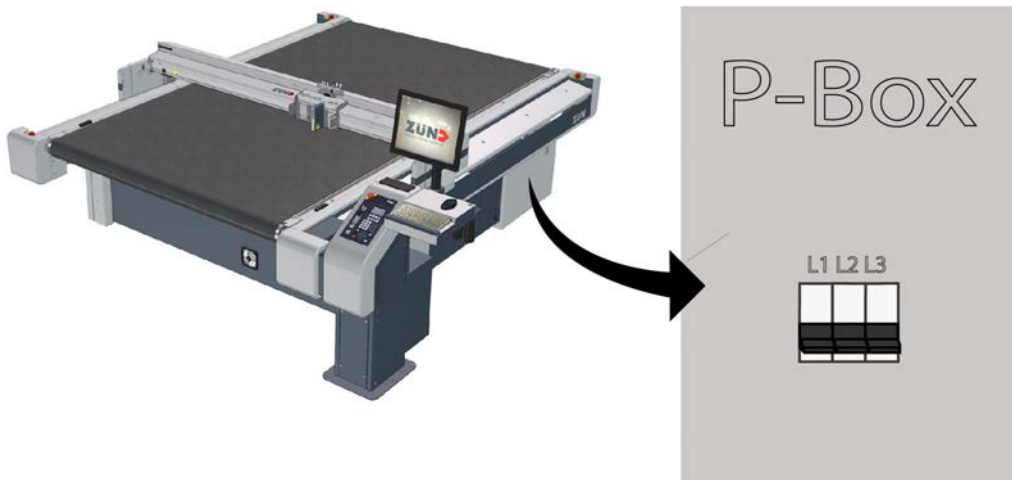

Fuse	Rated current	Consumer
L1	16 A type C	Cutter control, compressor, PC
L2	16 A type C	Extractor, various options
L3	16 A type C	Auxiliary drive, router converter

A Stop work.

B Remove the outer cover of the power box (see [Remove the power box cover \(A10, A21\)](#)).

C Push the switch lever upwards when the automatic circuit breaker is triggered.

Option

The automatic circuit breaker triggers again

Description

Shut down the cutter. Report the defect to your service partner.

The circuit breaker can be engaged; after continuing work, the circuit breaker triggers again

Shut down the cutter. Report the defect to your service partner.

The automatic circuit breaker can be engaged and triggers again after continuing to work

—

D Install the power box cover.

4.8 Daily checks prior to start-up



Caution:

There is a risk of injury if the machine is damaged! Machine faults can result in defects and accidents.

- Never start up a machine if it is damaged.
- Report all defects and faults to your supervisor and arrange for them to be rectified immediately by qualified personnel.

Ensure that all maintenance and service tasks are performed in accordance with the maintenance schedule.

Before starting up the machine each day, perform an inspection of the machine and check the following:

- Visually inspect the machine for damage.
- Remove local dirt caused by processing materials and dust.
- Remove objects from the work surface and the beam.
Remove objects from the work surface and the beam.
- Check whether all maintenance and service covers are installed correctly.
- Ensure that all EMERGENCY STOP control devices are easy to access and not hidden.

4.8.1 Checking the light curtain



Test piece

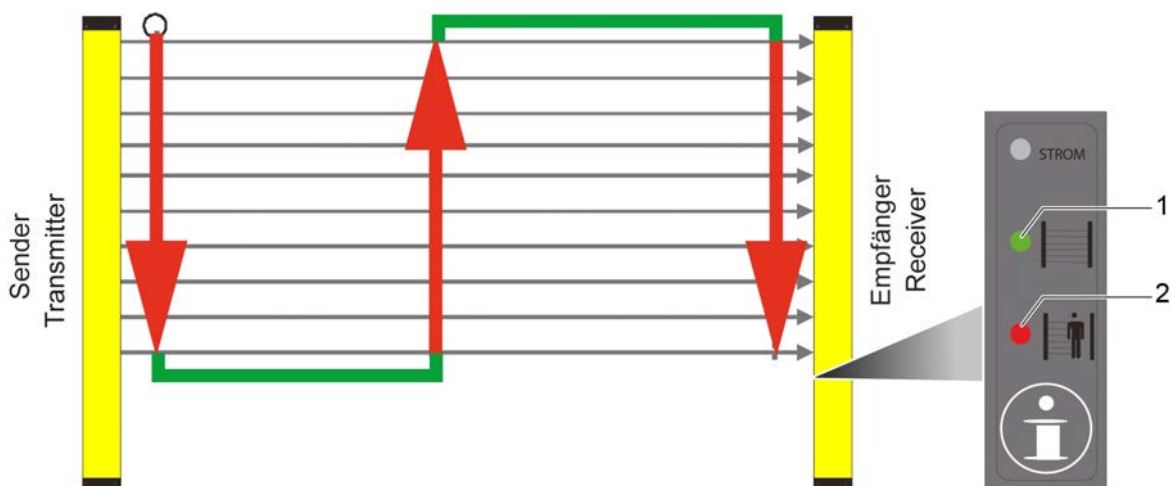

Figure 1: Inspection process on the yellow light grid (type 445L)

- 1 green LED = Light curtain without interruption
- 2 red LED = Light curtain interrupted

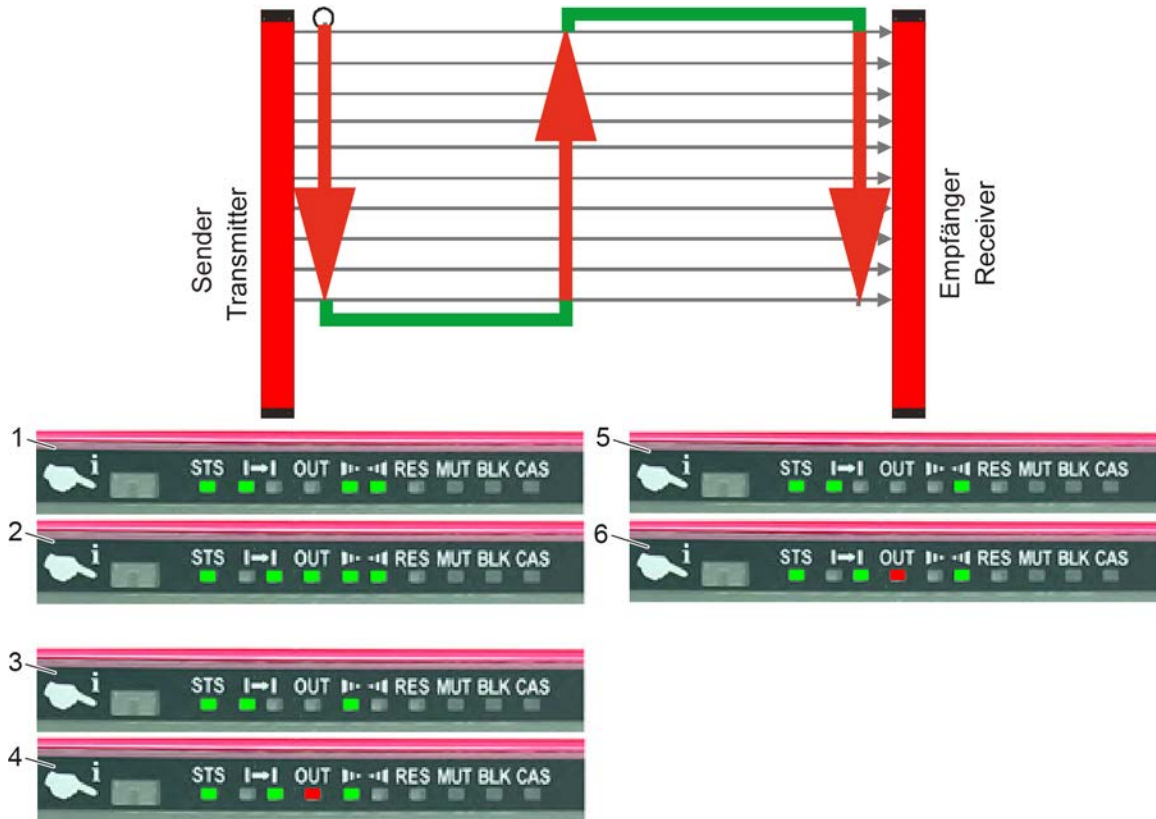

Figure 2: Inspection process on the red light grid (type 450L-E)

- | | | | |
|---|----------------------------------|---|--------------------------------|
| 1 | Transmitter without interruption | 4 | Top receiver interrupted |
| 2 | Receiver without interruption | 5 | Bottom transmitter interrupted |
| 3 | Top transmitter interrupted | 6 | Bottom receiver interrupted |

A Switch on the cutter (e.g., press the F1 key).

B Start the self-test with the **3-3-8 S-Test** menu.

C Pull the test piece as shown through the light curtain.

The beam movement stops immediately.

The light curtain indicates an interruption in the monitored area (a red LED on the receiver lights up).

D Press the "OK" soft key.

E Carry out the procedure in three places for each light curtain.

F For cutters with material transport, test processing with material and check for correct functioning of the light curtain.

4.9 Behavior in dangerous situations

4.9.1 Shutdown in an emergency

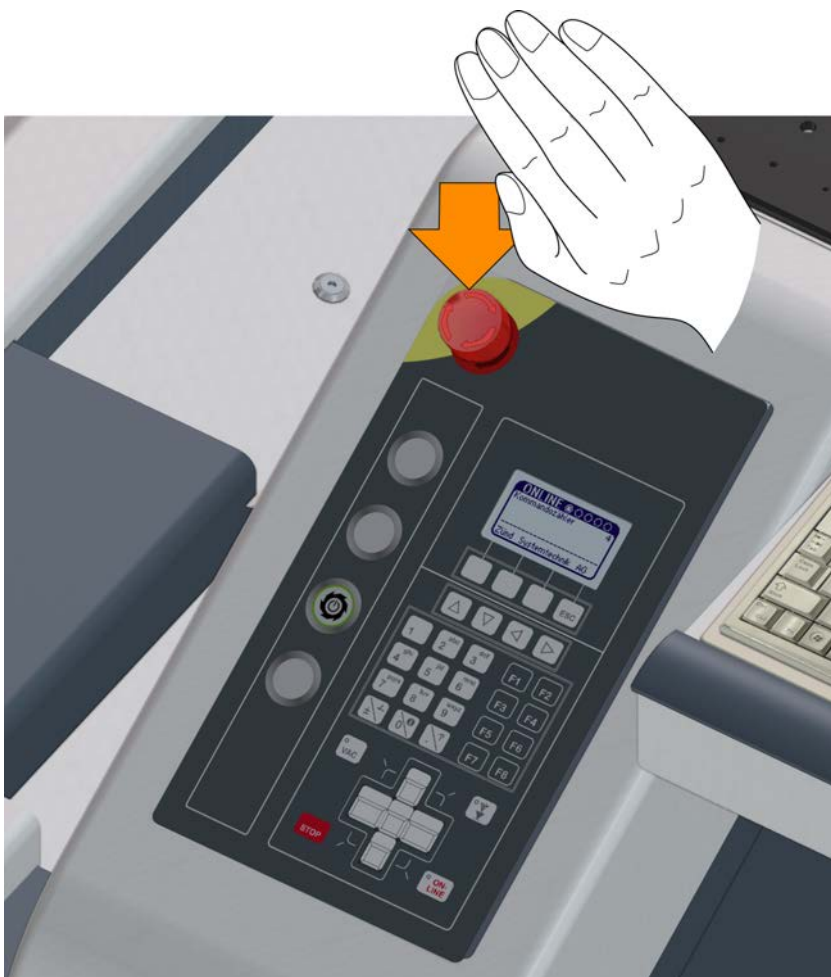

When a hazard or a possibly hazardous situation occurs, activate an EMERGENCY STOP control device immediately.

Effects for the cutter

- The drive motors (beams, module carriers) are braked to a standstill and are then disconnected from the energy supply.
- The drive axes are free and can be moved by hand.
- The cutter switches to STOPPED mode.
- Safety-related units (modules, tools, auxiliary drive...) are isolated from the energy supply.
- Units that are not safety-relevant or important for the operation of the machine, such as the operating unit, remain switched on.
- An error message is displayed.
- A warning tone sounds.
- The EMERGENCY STOP control device remains locked in the off position.

Effects on the options connected to the cutter

- All potentially hazardous movements are stopped.
- Units that are not safety-relevant or important for the operation of the machine remain switched on.

4.9.2 Reset EMERGENCY STOP control devices

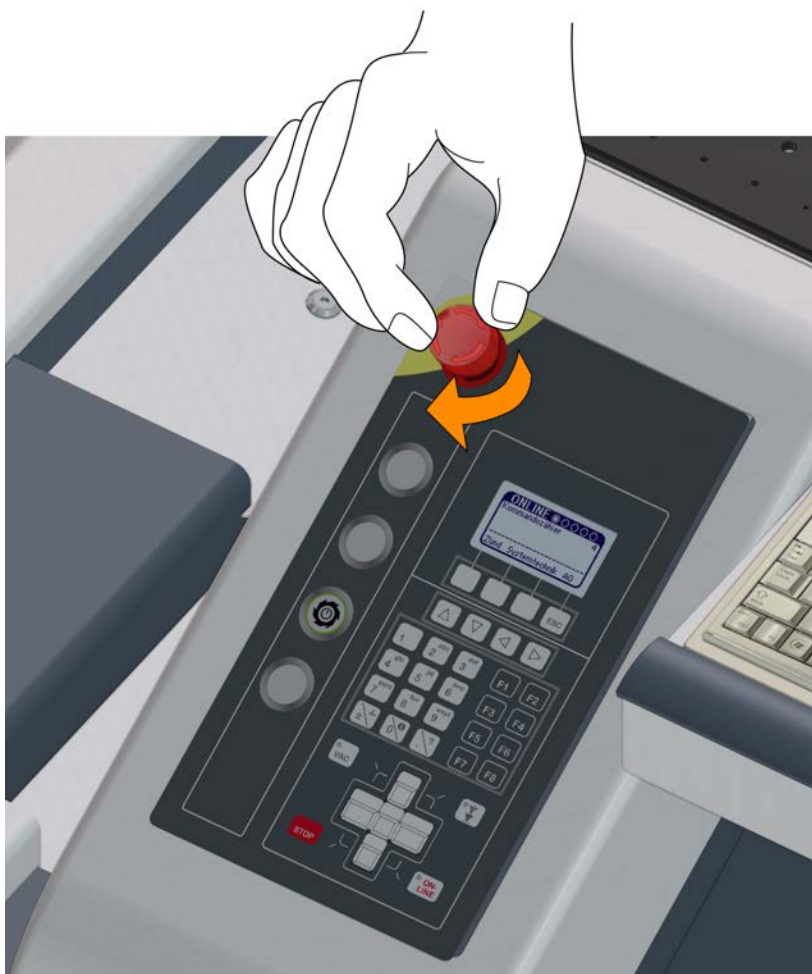

- A** Restore operational safety.
- B** Turn the EMERGENCY STOP control device clockwise to unlock.
- C** Acknowledge the error message on the control panel.

Results

The machine is ready for operation.

4.9.3 Commissioning a stopped machine

The cutter automatically shuts down under the following circumstances:

- An object is interrupting the light barrier.
- The safety device on the beam ends is triggered
- An object is interrupting the light curtain (optional).
- The distance between the two beams is too small.
- The drive of an axis is overloaded or blocked

- A** Remove the object and restore operational safety.
- B** Confirm the error message on the operating unit.
- C** Bring the machine into ONLINE mode to continue processing.

4.10 Start-up

4.10.1 Switch on the machine

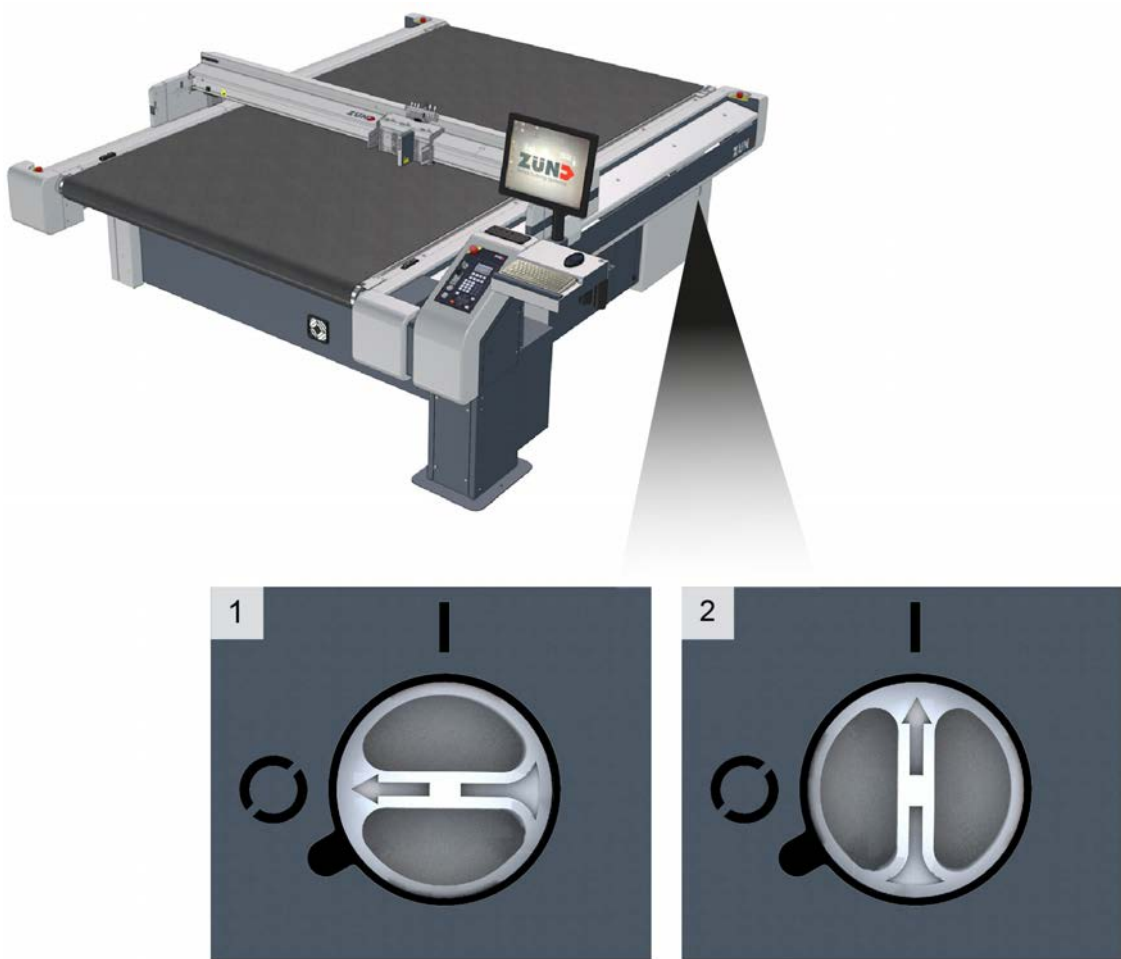

- 1 Main switch, off position
- 2 Main switch, on position

Switch the main switch to the on position.

Results

The cutter switches on. The start page appears on the display.

4.10.2 Initialize the machine



Caution:

Risk of injury due to automatic starting of the machine

Following initialization, OFFLINE mode is active. The cutter can receive commands from the operating software which activate the ONLINE mode.

- Switch on the operating software only after initialization of the machine.

Press the  function key on the operating unit.

Results

The cutter is initialized.

4.10.3 Switching off the machine

A Switch the cutter to OFFLINE mode.

B Select the **12 Turn off cutter** function from the menu or press the key combination **SHIFT + **.

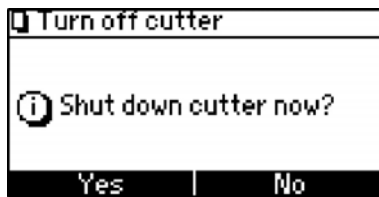

C Confirm the dialog with **Yes**.

D The start page appears on the display.

E Switch off the cutter with the main switch. If necessary, secure the main switch using a lock to protect the machine against improper startup.

F Clean the machine to remove dust and material residues.

4.11 operating mode

The cutter can be put into three operating modes:

- OFFLINE
- ONLINE
- STOPPED

A combination of keys can optionally be used to switch from any operating status to either of the other two operating modes.

The current operating mode is displayed in the header of the main menu and with the LED of the ONLINE key.

4.11.1 Change operating status

The following graphic demonstrates how to change from the current operating mode to another mode:

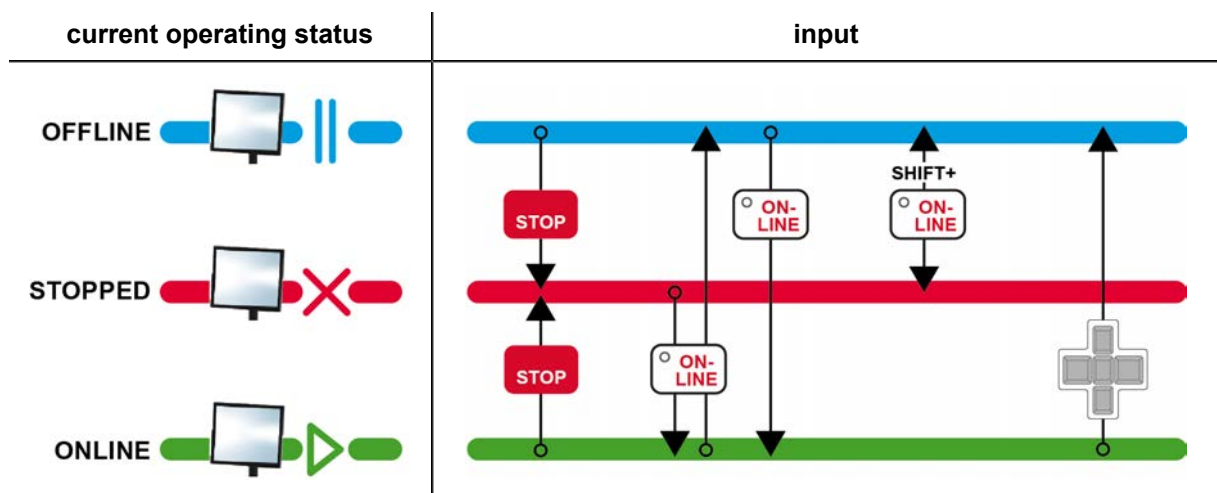

4.11.2 OFFLINE



Caution:

Risk of injury due to automatic start-up of the cutter

In OFFLINE mode, the cutter receives commands from the operating software. These commands can be used to switch to **ONLINE** mode.

- Activate the **STOPPED** operating mode during breaks.
- Always perform set-up work on the machine in **STOPPED** mode.

After the cutter is switched on, **OFFLINE** mode is active. In this mode, external commands are received but they are not processed.

Operating software commands can be used to switch to the **ONLINE** operating mode.



A red flashing LED on the ONLINE key indicates that the **OFFLINE** operating mode is active.

4.11.3 STOPPED

**Note:**

The operating mode **STOPPED** protects the operator from the machine being set in motion using remote controls.

In this operating mode, commands are received but they are not processed. Even commands from the operating software (e.g., to change to the **ONLINE** operating mode) are ignored.



A red illuminated LED on the **ONLINE** key indicates that the operating mode **STOPPED** is active.

4.11.4 ONLINE

Commands are received and processed in this operating mode.

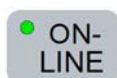

A green illuminated LED on the **ONLINE** key indicates that the operating mode **ONLINE** is active.

4.12 Moving the beam/module manually

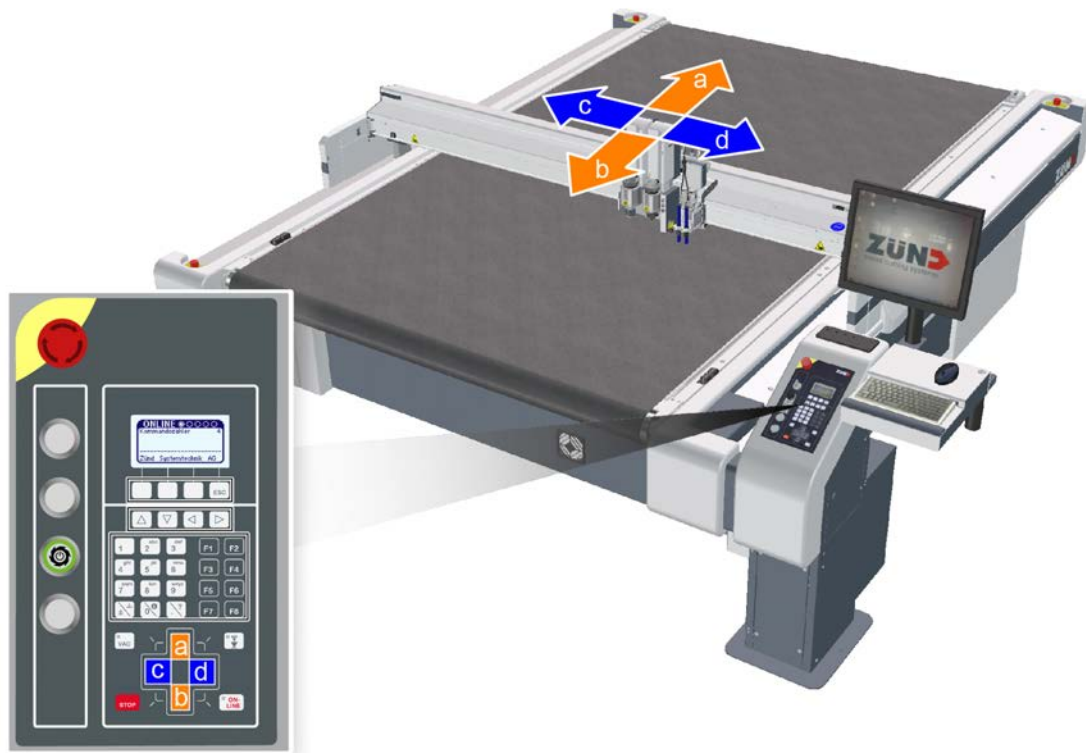

The module carriage can be moved using the travel keys in the OFFLINE and STOPPED operating modes. The assignment of the keys corresponds to the direction of travel.



Tip:

- Pressing the SHIFT key at the same time as the travel key will make the module carriage move faster.
- Pressing a travel key in the X and Y direction at the same time will make the module carriage move diagonally.
- If one or more travel keys are pressed in ONLINE mode, then all movement is stopped. The cutter is switched to OFFLINE mode.

4.13 Handling modules/tools

Modules are independently recognized by the cutter control unit. Tools, on the other hand, do not have automatic recognition and must be manually allocated to a module.

Tool-specific parameters (initialization, moving speeds, acceleration) are saved to the corresponding tool and can be called up again at any time.

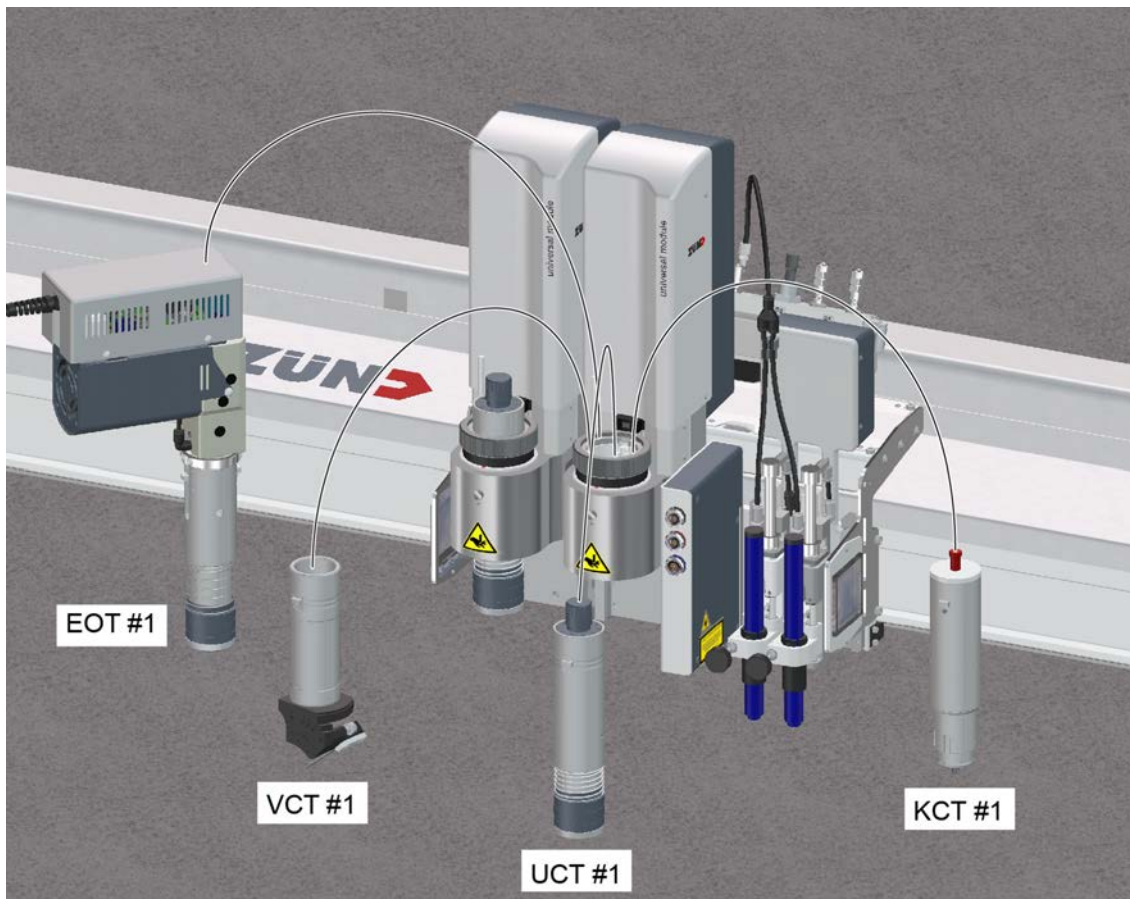

4.13.1 Module/tool/tool insert



Tip:

You will find detailed information in section [Modules, tools](#) on page 15 as well as in the individual instructions of your modules and tools.

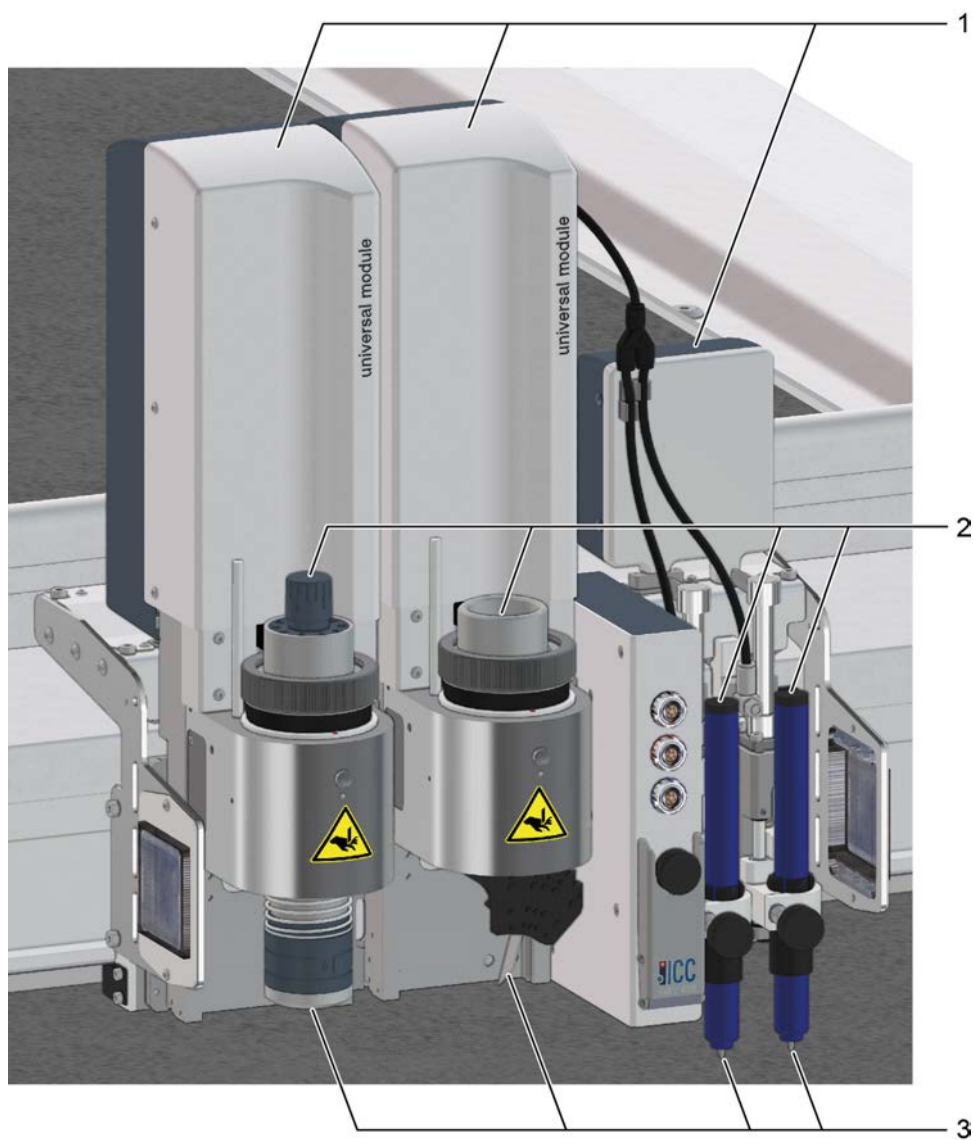

- 1 Module (e.g., UM, MAM)
- 2 Tool (e.g., UCT, VCT, SDT)
- 3 Tool insert: router, blade, pen

4.13.2 Module/tool change position

(can be set at operator user level or higher)

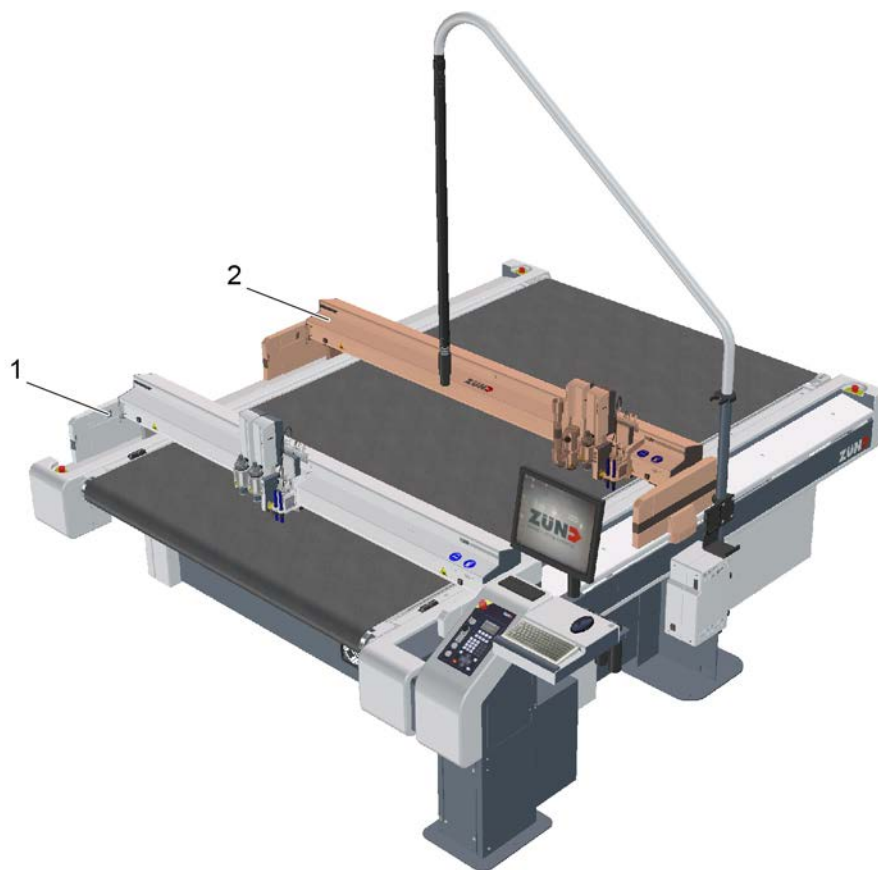

- 1 Example: module/tool change position 1 (changing standard modules)
- 2 Example: module/tool change position 2 (changing the RM-A/RM-L)

4.13.2.1 Define position

You can define any two positions at which the module changes can take place.

Position 1 (**1-5-7-2 Position 1**) and position 2 (**1-5-7-5 Position 2**) are set in the same way. The setting of position 1 is described by way of the example below.

A Select **1-5-7-2 Position 1**.

B Place the module carriage in the desired position using the travel keys.

C Confirm with **OK**.

4.13.3 Inserting/replacing the module

4.13.3.1 Module carriage

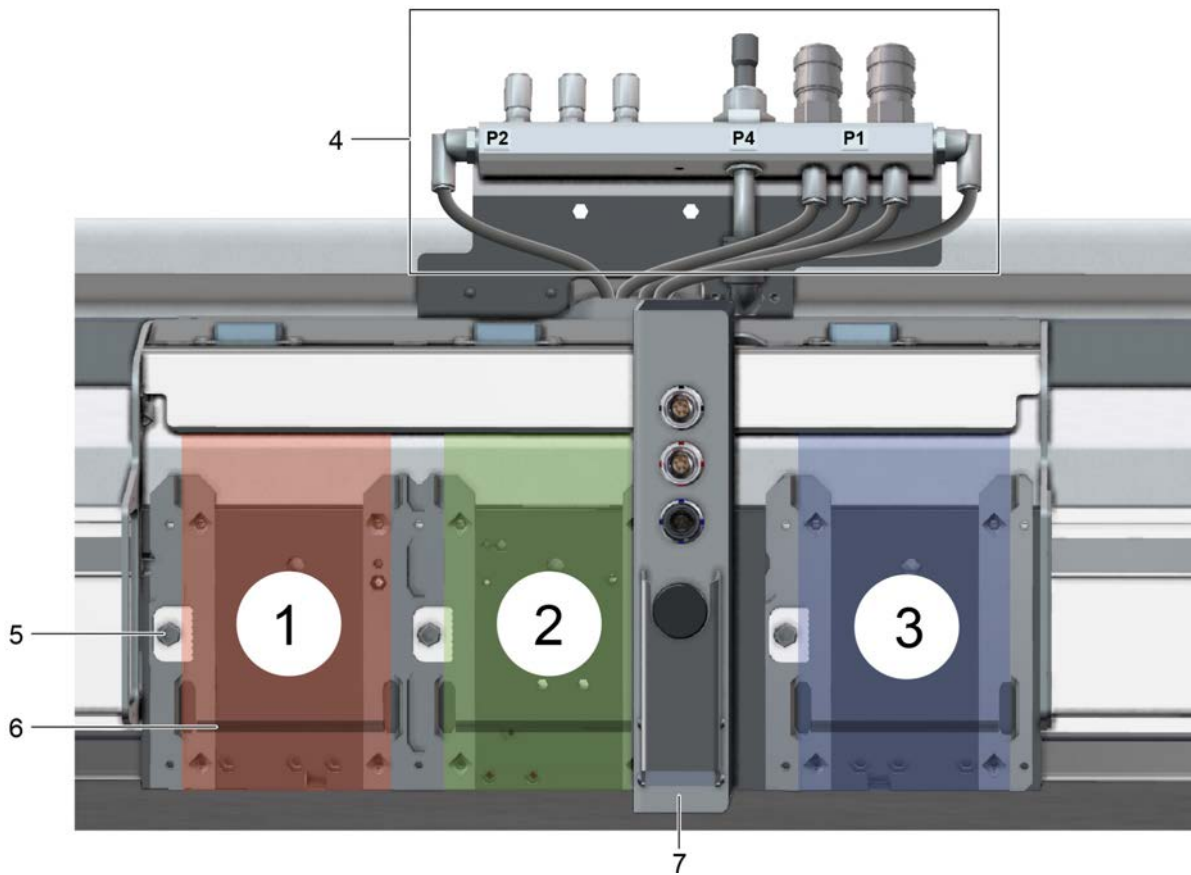

- 1 Module carriage, slot 1
- 2 Module carriage, slot 2
- 3 Module carriage, slot 3
- 4 Pneumatic connections
- 5 Locking mechanism
- 6 Drop bar
- 7 Laser pointer/camera (optional) with electrical connections

4.13.3.2 Inserting a module

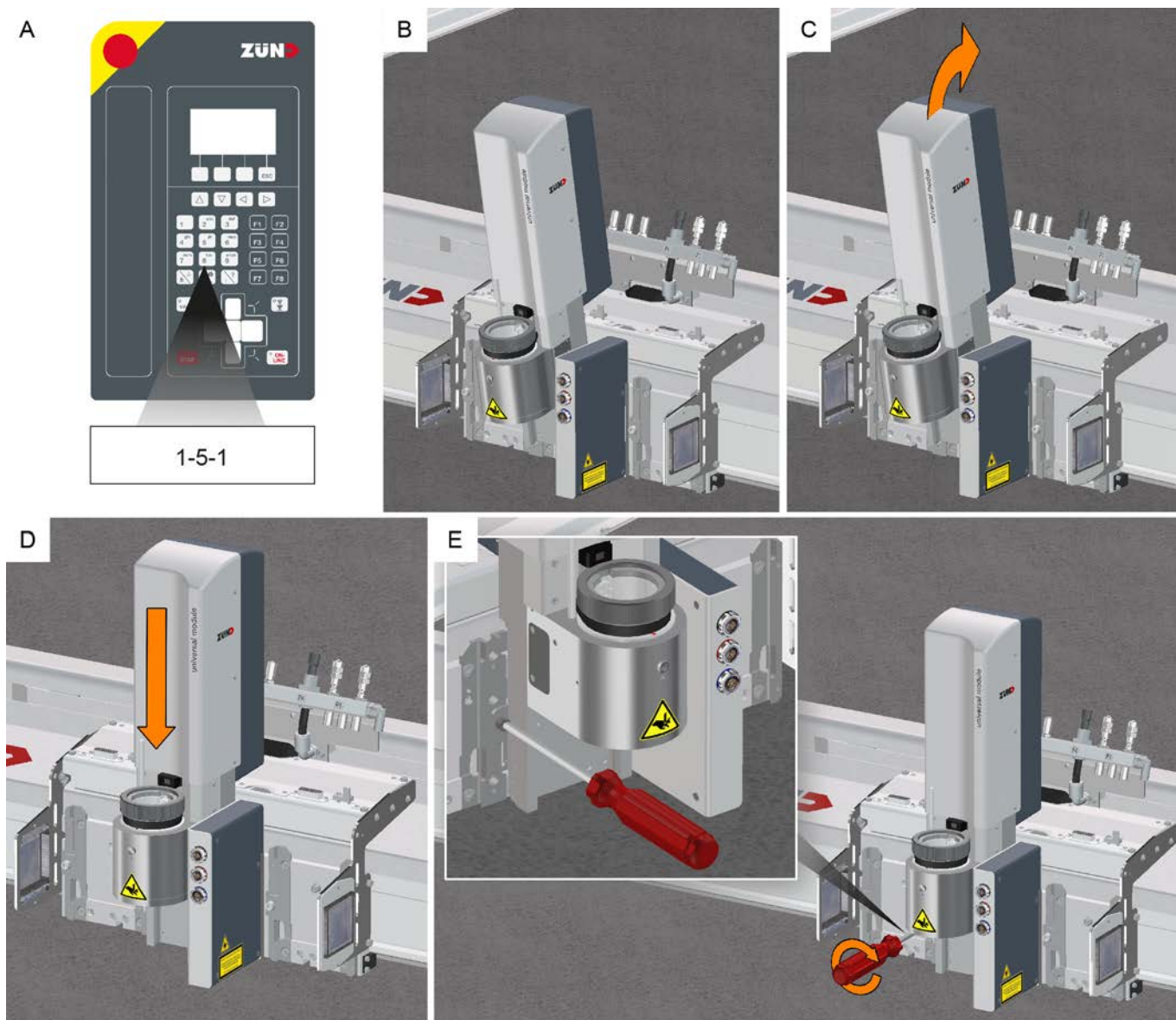
**A 1-5-1 Change module/tool .**

The module carriage moves to the module change position.

B Place the module on the mounting ledge.

C Tilt the module backwards onto the module carriage.

D Lower the module until the stop.

E Use the 4 mm Allen key to lock the module in place.

Results

The module is now mounted and is located by the software.

4.13.3.3 Removing the module

- A** Select **1-5-1 Change module/tool** in the cutter menu.
The module carriage moves to the module change position.
- B** Unscrew the module fastener using the 4 mm Allen key.
- C** Remove the module.

4.13.4 Activating a module

It is often necessary to activate a module in order to check the settings. This function can only be carried out in the main menu. The active module can for example be used as a pointer to define the vacuum width or the reference point.

Module	Key combination
Module 1	Shift + 1
Module 2	Shift + 2
Module 3	Shift + 3
ICC camera	Shift + 8
Laser pointer	Shift + 9

4.13.5 Marking the tool

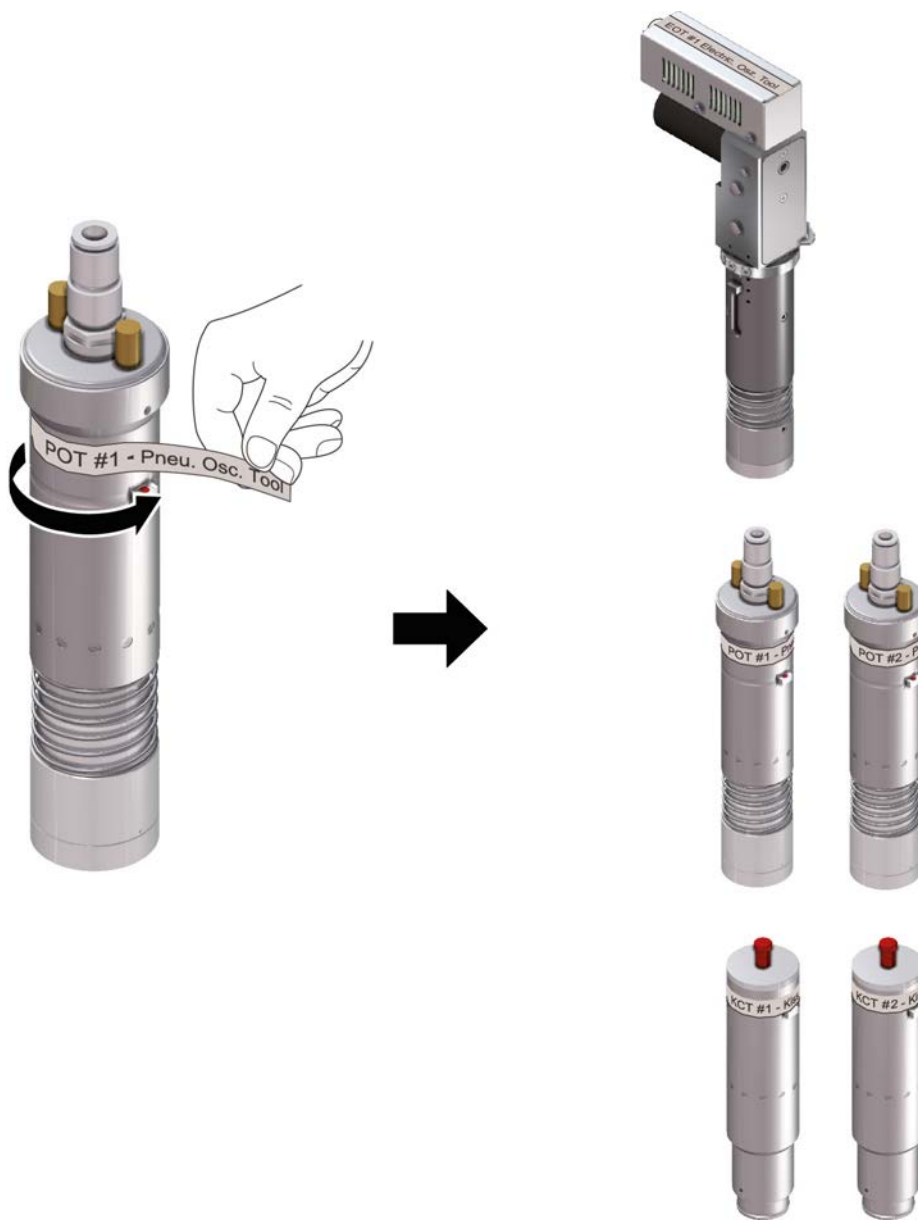

Label all tools of the same type with a consecutive number. Corresponding adhesive labels are supplied with the equipment.

4.13.6 Tool manager

The tool manager is a user interface to handle tools in combination with a universal module (UM). A sensor on the module detects the **presence** of the inserted tool.

The tool manager helps you carry out the following activities:

- Inserting a tool
- Attach/select a tool
- Initialize a tool

4.13.6.1 Inserting/replacing the tool

- A** Select **1-5-1 Change module/tool**.
- B** If necessary, select the module/tool change position.
- C** Insert the tool and - if electrically or pneumatically driven - connect to the power supply.
- D** Confirm the selection with **OK**.
The tool manager opens.

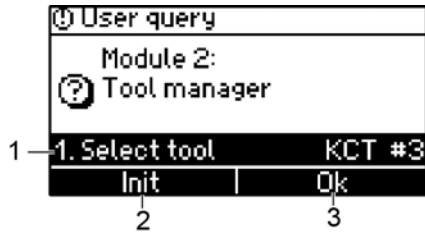

- 1 Use  to switch to the **1-1-1-1 Select tool** menu to select the tool used (see [Creating a new tool](#) on page 102 and [Selecting a tool already inserted](#) on page 103).
- 2 Use **Init** to switch to the menu for manual or automatic initialization. After initialization the parameters are saved. The tool manager closes and the main menu appears.
- 3 Confirm the tool selection with **OK**. The previously used parameters for this tool will continue to be used.

4.13.6.2 Creating a new tool

The tool is inserted in the module.

- A** Select **1-1-1-1 Select tool** in the menu.
- B** Select **NEW**.
- C** The **Create new entry** pop-up menu opens.

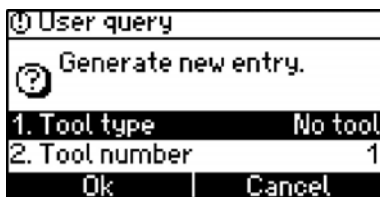

- D** Select the **Tool type**.
All tool types that can be used in the current module are displayed in the popup menu **Tool type**.



Select the tool from this list and confirm with **OK**.

- E** Enter the appropriate number of the tool in the pop-up menu **Tool number** and confirm with **OK**.

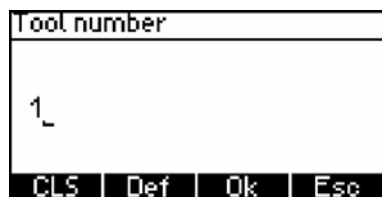

4.13.6.3 Selecting a tool already inserted

- A Insert the tool.
- B Select **1-1-1-1 Select tool** in the menu.
In the **dialog**, **all tools already assigned to this module are listed**.
- C Select the tool inserted.

4.13.6.4 Deleting a tool

- A **1-1-1-1 Select tool** .
All tools already assigned to this module are listed in the **tool type** dialog.
- B Select the tool.
- C Delete the selected tool with `Delete`.

4.13.6.5 Saving tool-specific settings

Use `ESC` to change to the main menu.

Results

The tool-specific settings that have been made are automatically saved.

4.13.7 Connecting powered tools

Driven tools (e.g. EOT, DRT, POT) require an energy supply (electrical, pneumatic). This energy supply is controlled by the cutter control unit.

Electrically driven tools are connected to the connector control of the laser pointer or the ICC camera (optional). A port is allocated to each individual connection which must be assigned via the cutter control unit before the initial commissioning of the respective tool.

Pneumatically driven tools are connected to the pneumatic connections on the module carriage.

4.13.7.1 Connecting electrically driven tools

The tool is applied and assigned to the module.



Tip:

The plug of the connecting cables on the electrical tools have the same color code as those on the connecting sockets.

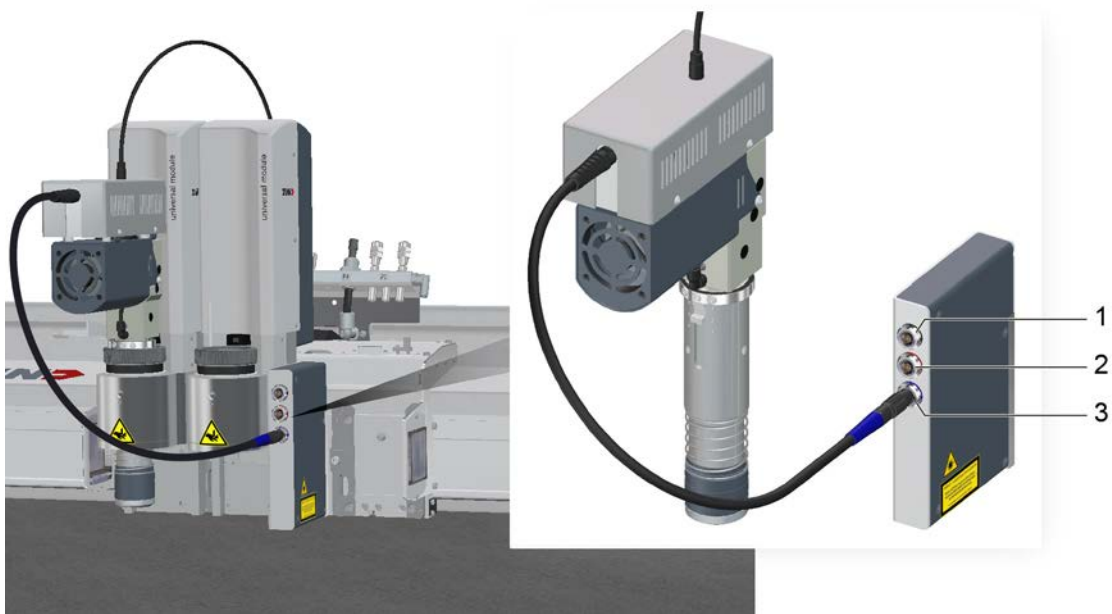

- 1 Connection 1 (port 1, black) - e.g. EOT
- 2 Connection 2 (port 2, red) - e.g. DRT
- 3 Connection 3 (port 3, blue) - e.g. EOT-250, URT

- A** Insert the tool into the color-coded connection provided.
- B** Allocate the corresponding port to the tool with **1-1-1-3-1-1 Port**.

4.13.7.2 Connecting pneumatically driven tools

The tool is applied and assigned to the module.

Pneumatically driven tools and modules are connected to the pneumatic connections on the module carriage. The pressure is set using a maintenance unit (see [Compressed air settings](#) on page 36). The air supply is connected to the local installation or supplied via a compressor. The connection data as well as an exact connection procedure can be found in the operating manual for the respective tool/module.

**Note:**

Always use a protective plug to protect connection P4 from dirt in the air supply. If particles of dirt get into the tool, it will be damaged. For more information, see [Mount protective stoppers for pneumatic connection](#) on page 106.

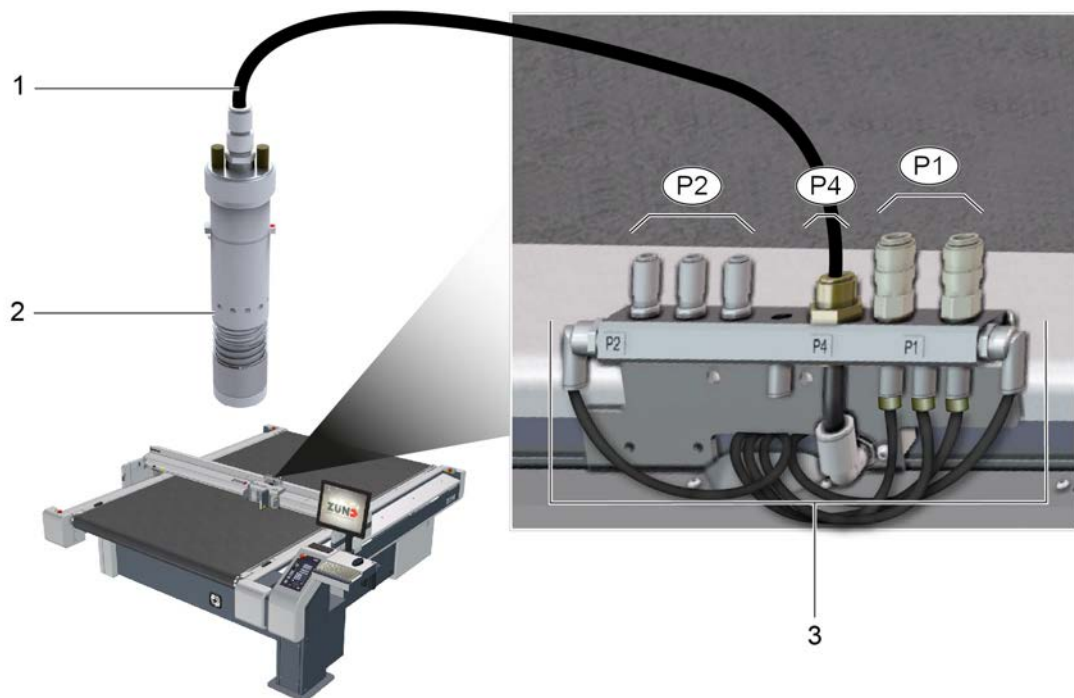

- 1 Compressed air hose
- 2 Pneumatically operated tool (e.g., POT)
- 3 Interface unit
- P1 Compressed air connection P1 (e.g. PUM)
- P2 Compressed air connection P2 (e.g. sealing air EOT-250)
- P4 Compressed air connection P4 (e.g. POT)

- A** Press down on the corresponding air pressure connection coupling.
- B** Insert the compressed air hose.

4.13.8 Mount protective stoppers for pneumatic connection



Note:

Always use a protective plug to protect connection P4 from dirt in the air supply. If particles of dirt reach the tool, it will be damaged.

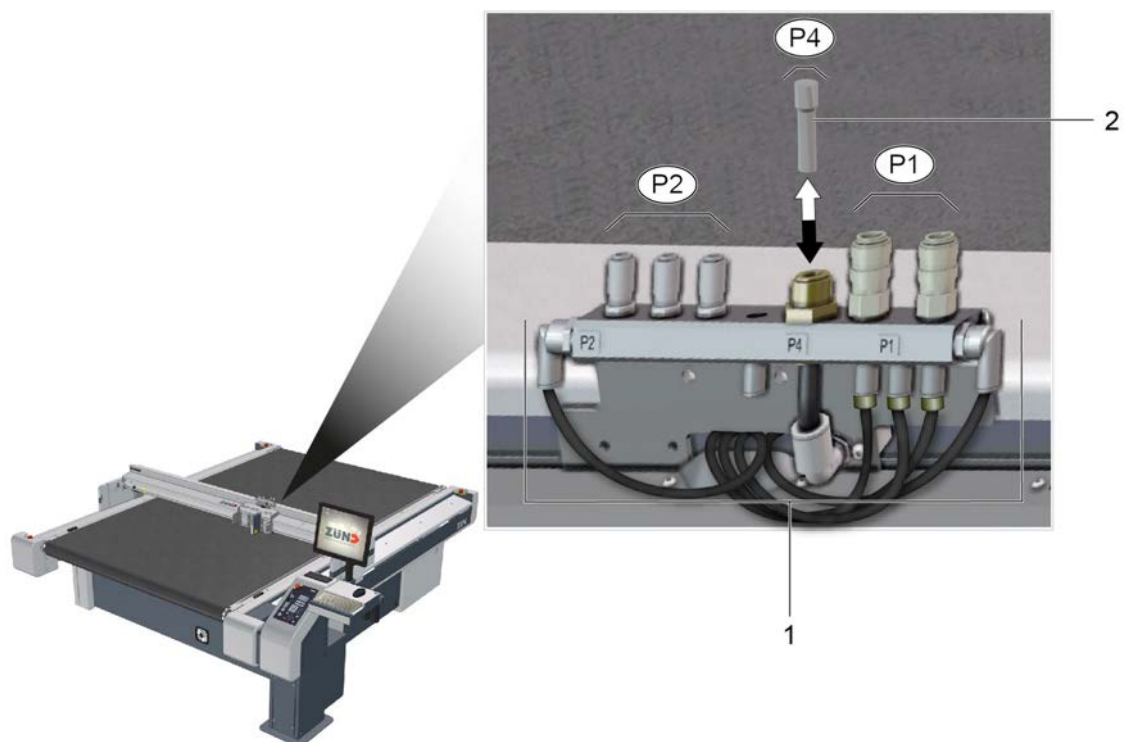

- 1 Interface unit
- 2 Protective plug
- P1 Compressed air connection P1
- P2 Compressed air connection P2
- P4 Compressed air connection P4

A Press down on air pressure connection coupling P4.





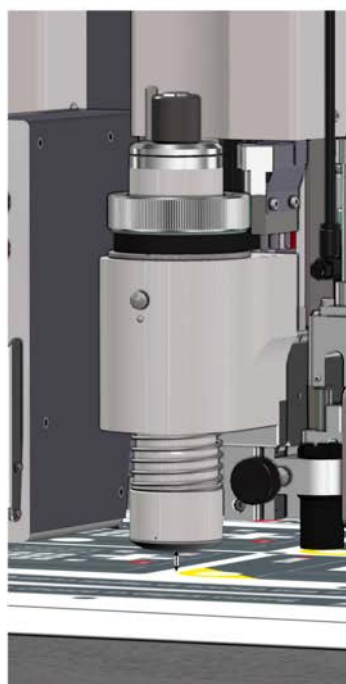
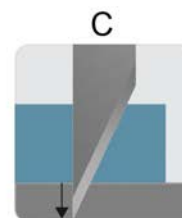
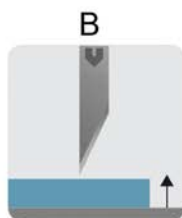
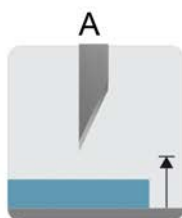

B Place the protective plug in the coupling.

4.13.9 Tool positions, Z axis

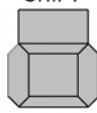
E.g.: UCT

After initialization, three tool positions can be moved to with .



Pos.	Position	Description	Key	Signal
A	Parking position	Moves to the highest position on the Z axis	SHIFT  + 	
B	Up position	Zero point + up position		
C	Down position	Zero point + Down position + Z offset		

4.14 Material fixing

4.14.1 Standard vacuum plate

The material hold-down takes place via a vacuum. For this purpose, the table plate of the machine is divided into 0 - X vacuum zones. The number of zones is dependent on the size of the cutter.

The width of the **continuously active** vacuum zone 0 is:

- 470 mm for M, L and XL machines
- 940 mm for 2XL machines
- 1410 mm for 3XL machines

The width of every further vacuum zone that can be activated is approx. 80 mm in all models. Vacuum zone 0 is positioned on the right-hand side of the worktop; all other zones can be sequentially switched on/off from right to left.



Tip:

The strength of the fixing is variable and is set via the control panel. Only set the fixing to be as strong as necessary in order to save energy and so that the machine is not overloaded.

Depending on the size and the power requirement, either a vacuum turbine or a gas ring vacuum pump is used. Position the vacuum generator below or next to the cutter.

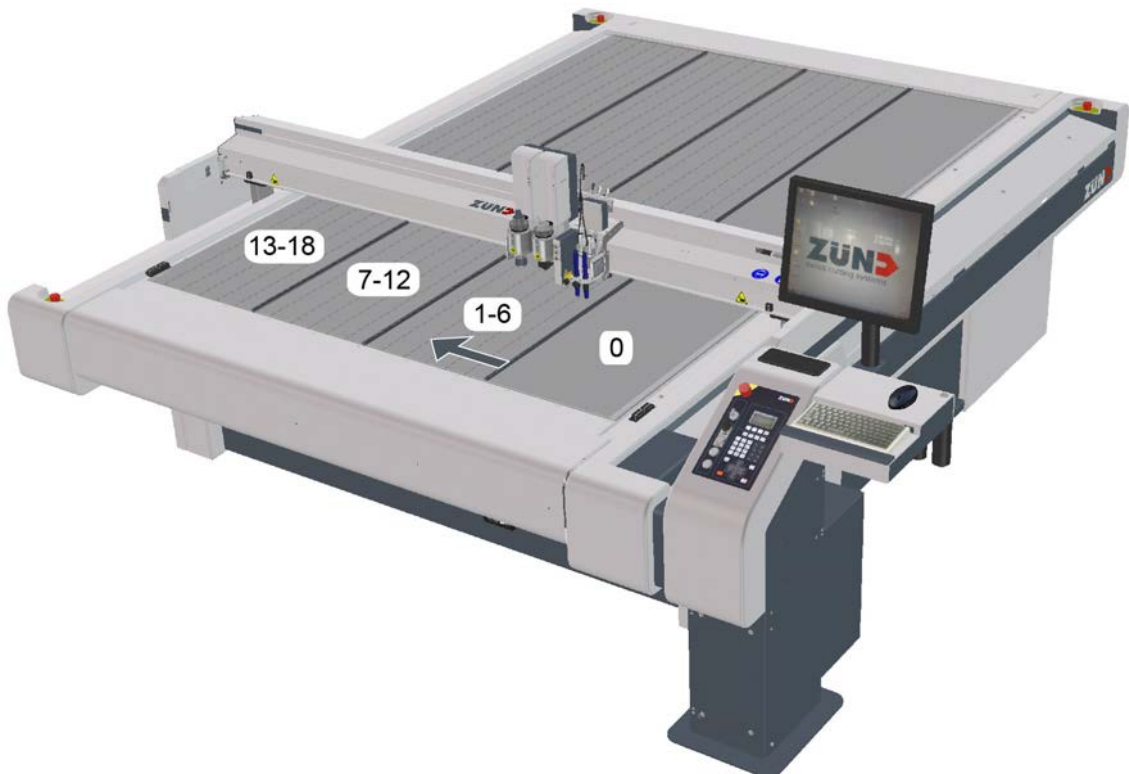

4.14.2 Covering open vacuum areas

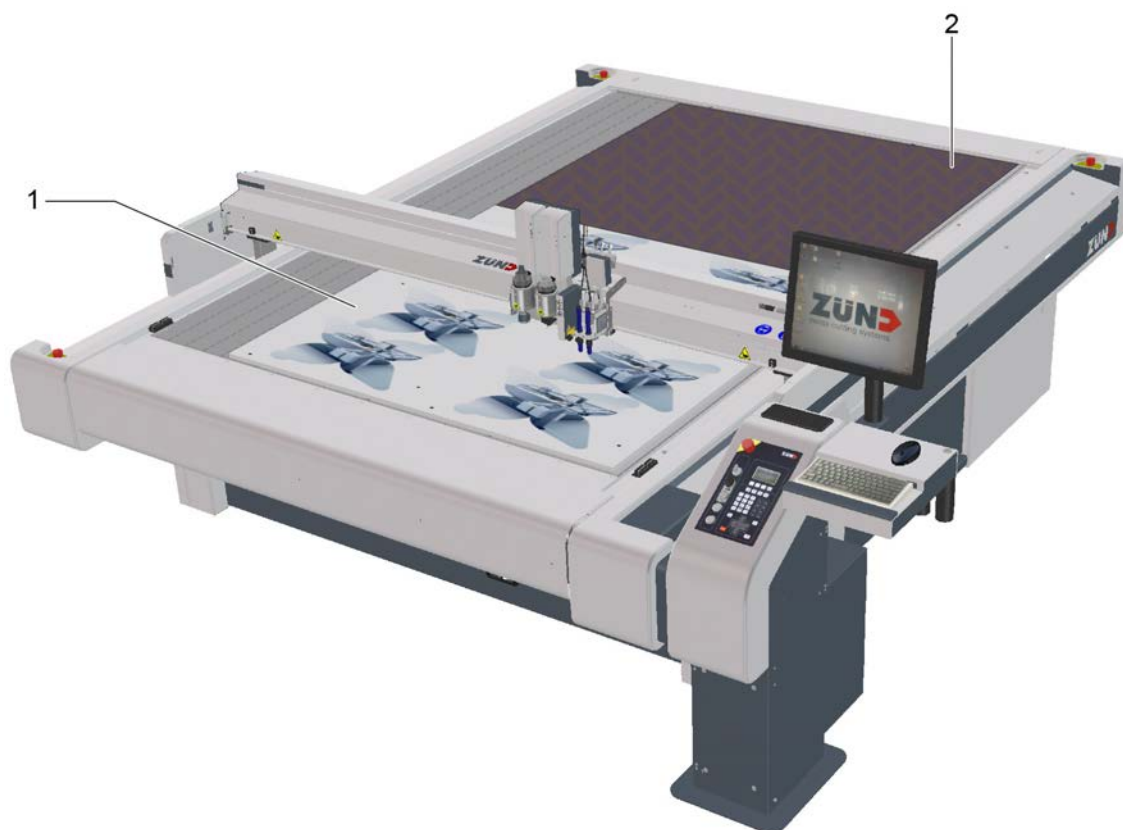

- 1 Processing material
- 2 Covering the open vacuum area

- A** If possible, position the material to be processed at the zero point of the work surface.
- B** Use a tarpaulin or airtight material to cover the open vacuum area.

4.14.3 Setting the vacuum range



- A Use the travel keys to position the *current pointer* over the left edge of the processing material.
- B Select the **1-8-3-4 Define vacuum range** function.
- C Confirm with **OK**.

Results

The vacuum range has been defined.

4.14.4 Checking the vacuum range

- A Select the **1-8-3-5 Active zones** function.
- B Select **OK** to confirm.

Results

The active module moves to the defined vacuum width.

4.14.5 Vacuum setting, both sides (optional)

Important:

This function is only available if the cutter is fitted with a leather vacuum plate or a tandem vacuum plate.

If this option is installed, the outer vacuum zones can be switched off and on from both sides when this is required. This avoids leakage air, and the vacuum only takes effect where it is actually required. The material has optimal fixing. In the following illustration, the distribution of the vacuum zones on the example of the L-2500 are shown.

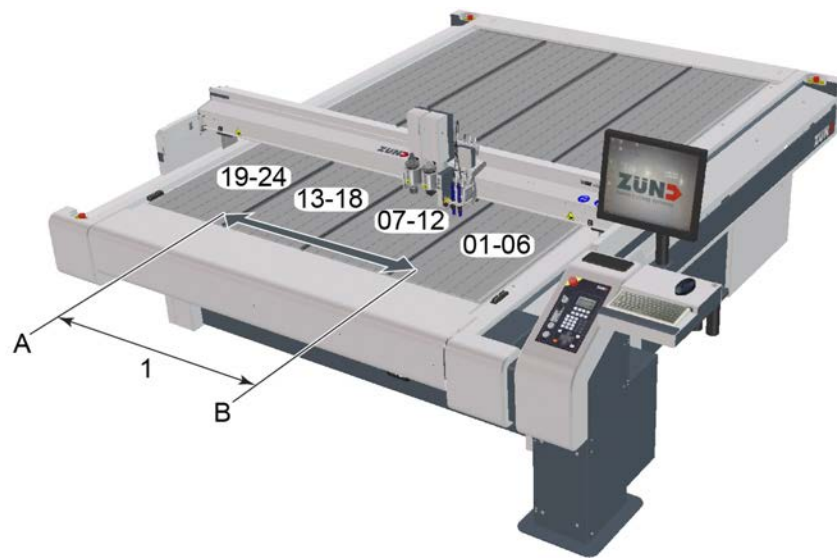

1 Switched on zones (active vacuum zone)

A Vacuum from

B Vacuum to

Menu settings

Menu	Description
1-8-3-1 Vacuum from	Display in mm, from which vacuum zone the vacuum is active.
1-8-3-2 Vacuum to	Display in mm, to which vacuum zone the vacuum is active.
1-8-3-3 Setting vacuum from	Place <i>the active pointer</i> on the Vacuum from position. 1-8-3-3 Setting vacuum from .
1-8-3-4 Setting vacuum to	Place <i>the active pointer</i> on the Vacuum to position. 1-8-3-4 Setting vacuum to Select.
1-8-3-5 Active zones	The positions Vacuum from and Vacuum to are moved to with the active pointer.
1-8-3-6 Active zones	Displays the number of active zones.

4.14.5.1 Implementing vacuum setting on both sides

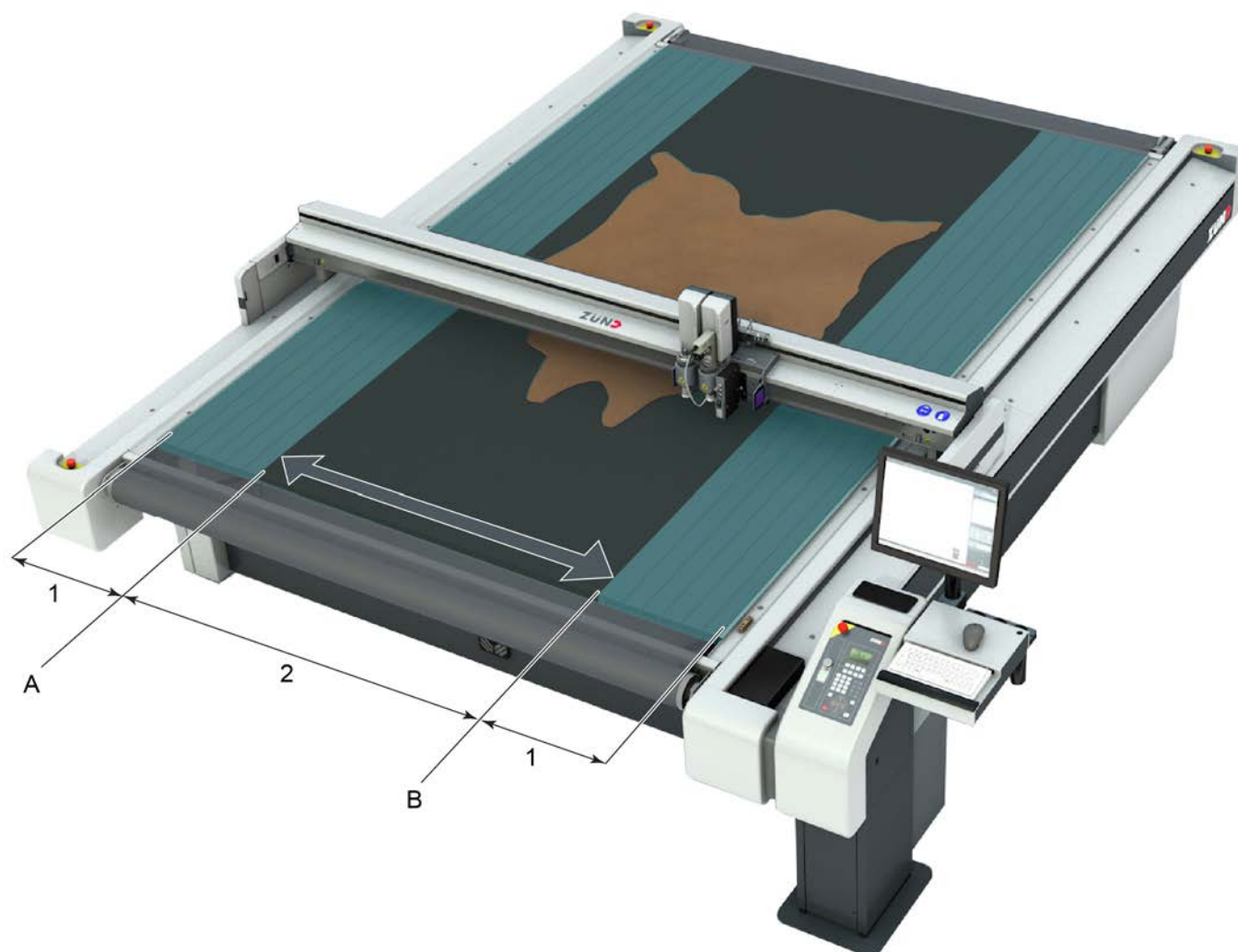

- 1 Switched off zones
- 2 Switched on zones (active vacuum zone)
- A Vacuum from
- B Vacuum to

A Place the material on the working surface.

B Place the *active pointer* on the **Vacuum from** position. Select **1-8-3-3 Setting vacuum from**.

C Place the *active pointer* on the **Vacuum to** position. Select **1-8-3-4 Setting vacuum to**.

4.14.6 Switching between air cushion / vacuum (optional)

Important:

This function is only available if the vacuum generator is fitted with a vacuum pump that has a changeover valve.

Machines which are fitted with a vacuum pump with switching valve produce an air cushion between the processing material and work surface during material transport. The vacuum is switched on after the feed.

Vacuum

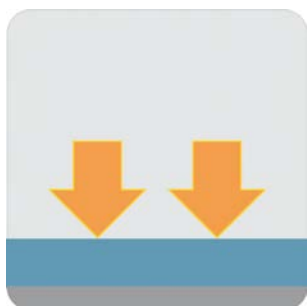

If Suction is activated, the processing material is held tightly against the work surface through suction. The processing material is held down against the work surface and does not move during processing.

Air cushion

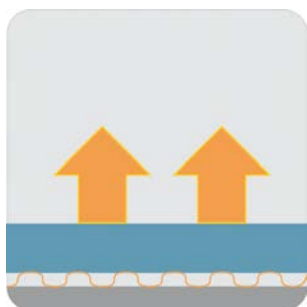

If Blowing is activated, blowing is switched on before a feed instead of suction. An air cushion is created between work surface and processing material.

There are two variants to choose from.

- This air cushion remains in place throughout the entire feed and thus supports the material transport
- The air cushion is only turned on shortly before the material transport.

manual switchover/switch on

A Press the  key.

B Press the **3** key.

Results

- The air cushion switches on or off.
- It switches between suction and blowing if the vacuum was switched on beforehand.

Air cushion before or during the material transport

Menu	Setting
1-7-1-17-1 Air cushion	Switch short blast before material transport on or off.
1-7-1-5 Vac. beh.	always fixed time-optimised

4.14.7 Setting the vacuum intensity (optional)

Important:

Regulation of the vacuum intensity is only possible, if your machine is fitted with a vacuum turbine.

The output of the vacuum turbine is adjustable from levels 1-10. Levels 1-9 are regulated by the negative pressure sensor of the cutter controller.

At level 10, the vacuum turbine operates at the highest power level without regulation.

	9 kW / 15 kW / 15 kW plus
Level 1	10%
Level 2	20%
Level 3	30%
Level 4	40%
Level 5	50%
Level 6	60%
Level 7	70%
Level 8	80%
Level 9	90%
Level 10	max.



Tip:

Observe the following advice to achieve a best possible material hold-down:

- Select a vacuum level appropriate for your material. The material can be damaged if the vacuum is too high (e.g., corrugated cardboard).
- Cover open vacuum areas. This allows you to select a lower power level.
- Only use level 10 for materials that are air-permeable and then only when processing requires it.
- If the vacuum turbine audibly no longer works at a constant speed, too high a vacuum level is set. Select a lower output level.

A Select the **3-1-1-8 Power level** function.

B Enter the required performance level and confirm with **OK**.

4.14.8 Switching the vacuum on/off

Variant 1

Press the key combination **SHIFT+** .

Variant 2

A Press the  key.

B Press the **2** key.

Variant 3 for tandem (optional)

A Press the  key.

B Press the **2** key.

The front vacuum switches on or off.

C Press the **5** key.

The rear vacuum switches on or off.

4.14.9 Working with air-permeable materials

The vacuum is controlled via a pressure sensor. When a vacuum is created, the speed of the vacuum generator is kept constant.

Because the air flow is too great with air-permeable materials for a vacuum to be created, the speed of the vacuum generator is increased with the aim of achieving the set vacuum.

To reduce the speed of the vacuum turbine, observe the following tips:

- Cover the processing material with a thin film.
- Process the air-permeable materials with driven tools (EOT, POT, DRT) in order to reduce the cutting forces and the required holding forces.

4.14.10 Cycle times

If your cutter is fitted with a vacuum turbine, the switching on/off of the turbine is bound to a cycle time. This is necessary for the vacuum generator to not overheat. The cycle times are monitored by the cutter control unit.

Vacuum turbine	Minimum cycle time
1-9 kW	15 seconds
1-15 kW	30 seconds
1-15 kW plus	60 seconds
Vacuum pump	Minimum cycle time
with switching valve	5 seconds

4.15 Material transport (optional)

Material transport takes place after a completed work step. In which the processing material is transported further on a conveyor belt.

The conveyor belt is gripped and fed using two clamping elements, while the processing material is fixed with transport elements or a transport bar.

The arrangement and activation of the transport elements is determined based on the processing material. If a transport bar is used, then all transport elements are activated or in fixed positions.

Depending on the size of the table or the processing material, an auxiliary drive is used to support the feed. The feed direction is defined via the position of the auxiliary drive.

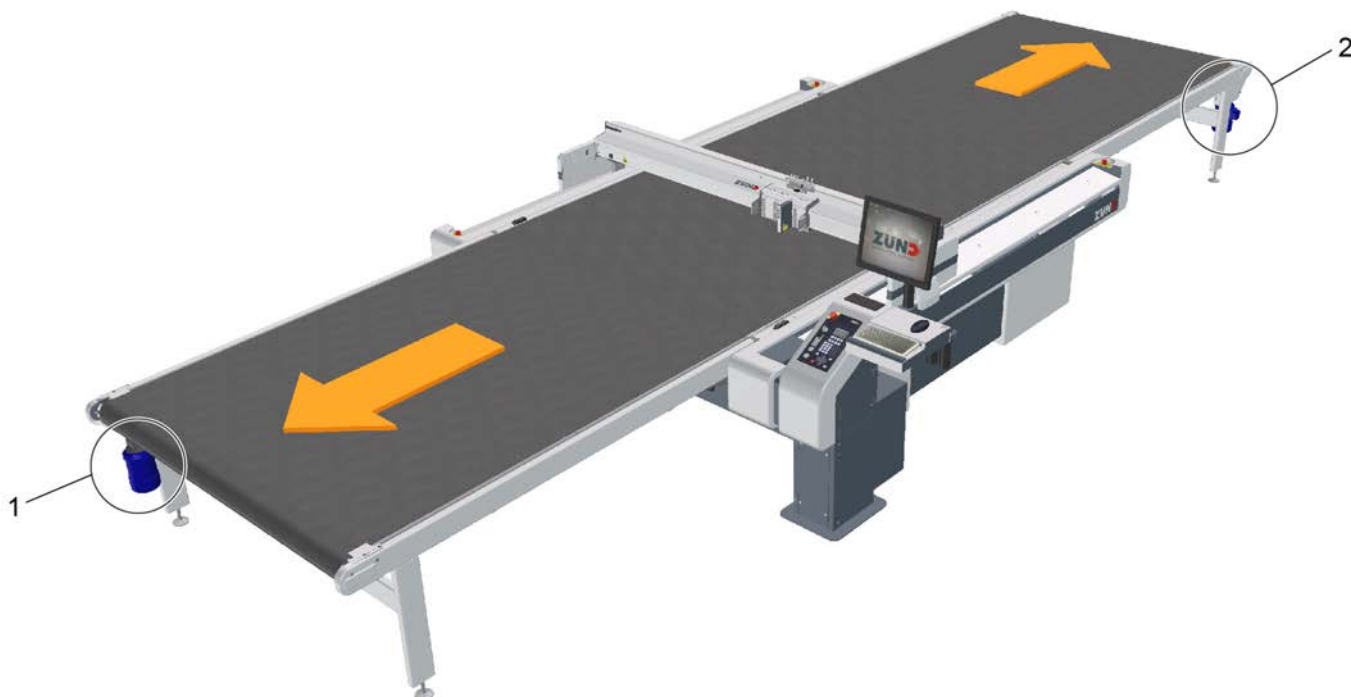

- 1 Front auxiliary drive: transports the material forwards
- 2 Rear auxiliary drive: transports the material backwards

4.15.1 Transport elements, transport bar (optional)

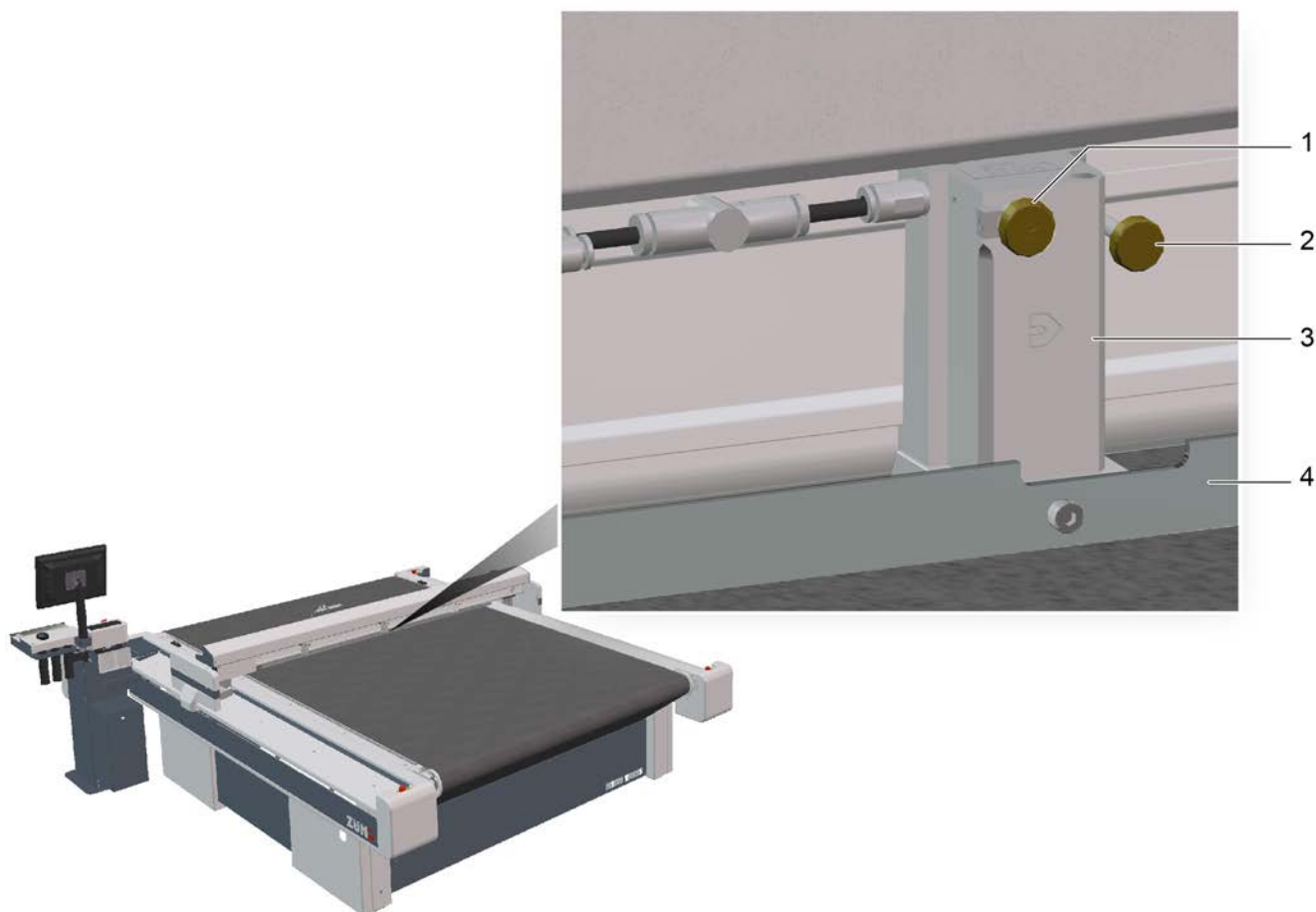

- 1 Screw, compressed air on/off
- 2 Screw to fix the transport elements
- 3 Transport element
- 4 Transport bar (optional)



4.15.1.1 Adjusting the transport elements

- A Loosen the screw for fixing the transport element.
- B Position the transport element (pay attention to the hose length).
- C Tighten the screw for fixing the transport element.

4.15.1.2 Activating/deactivating transport elements

- A Turn the compressed air on/off screw clockwise to deactivate the transport element.
- B Turn the screw anti-clockwise roughly three rotations to activate the transport element.

4.15.1.3 Installing the transport bar

- A** Turn off the cutter with **SHIFT** - .
- B** Loosen the transport element fixing.
- C** Position the transport elements.
- D** Loosely screw the transport bar to all transport elements using the supplied self-locking screws.
- E** Tighten the transport element fixing.
- F** Switch the cutter on with .
- G** Lower (**1-7-2-3 Lower feed clamps**) and raise (**1-7-2-3 Lift feeding clamps**) the transport bar several times for inspection purposes.

4.15.2 Feed

The following parameters can be set in the cutter menu:

- Speed
- Acceleration
- Feeding mode
- Function of the transport elements
- Feed direction

4.15.2.1 Manual feed

- A** Lower the transport elements (**1-7-2-3 Lower feed clamps**).
- B** Carry out a feed using the travel keys.
- C** Lift the transport elements (**1-7-2-3 Lift feeding clamps**).

4.15.2.2 Automatic feed

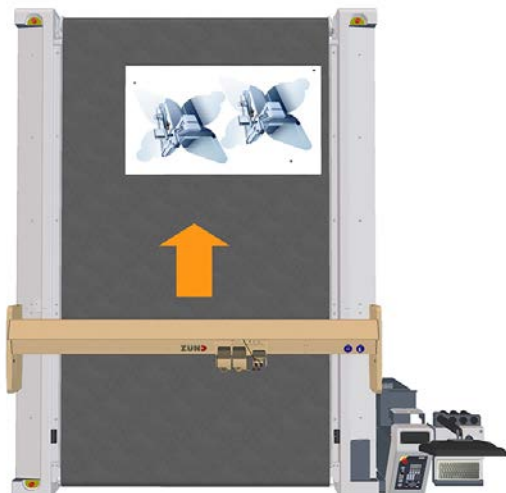

The feed length is defined (**1-7-1-2 Length**) during automatic feeding. If necessary, a starting point can also be defined for the feed.

If a feed is started, the beam moves to the starting point of the feed.

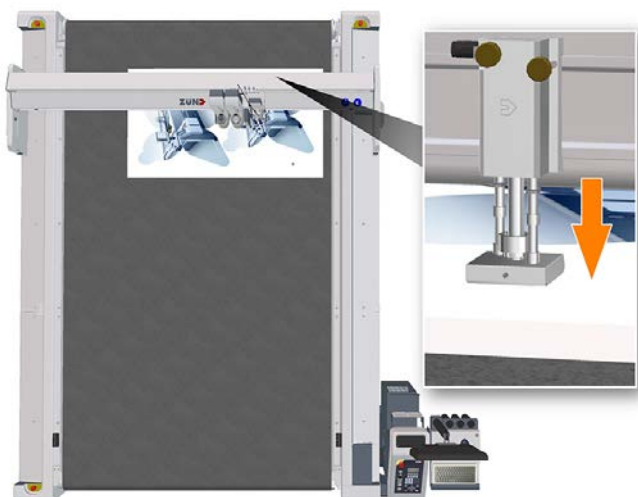

The transport elements are lowered and the conveyor clamp elements grip the conveyor belt.

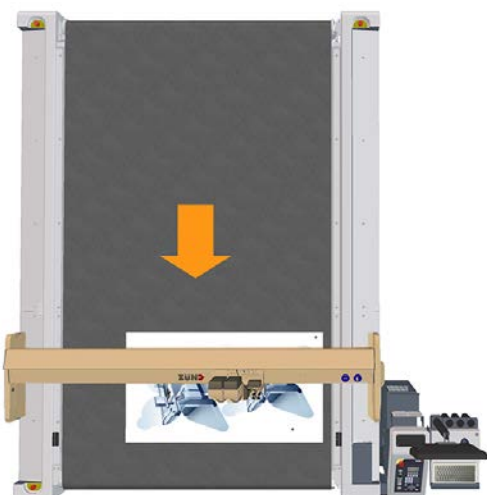

A feed is executed.

If the feed length is greater than the length of the work surface, this process is repeated until the specified length is reached.

4.15.3 Setting the air cushion (only 2.2 kW pump)



Tip:

Very light materials in particular can be lifted too much by the air cushion. The air flow for the air cushion can be set on the vacuum pump.

The valve can be switched manually when the vacuum pump is at a standstill. To do this, push or pull the knob.

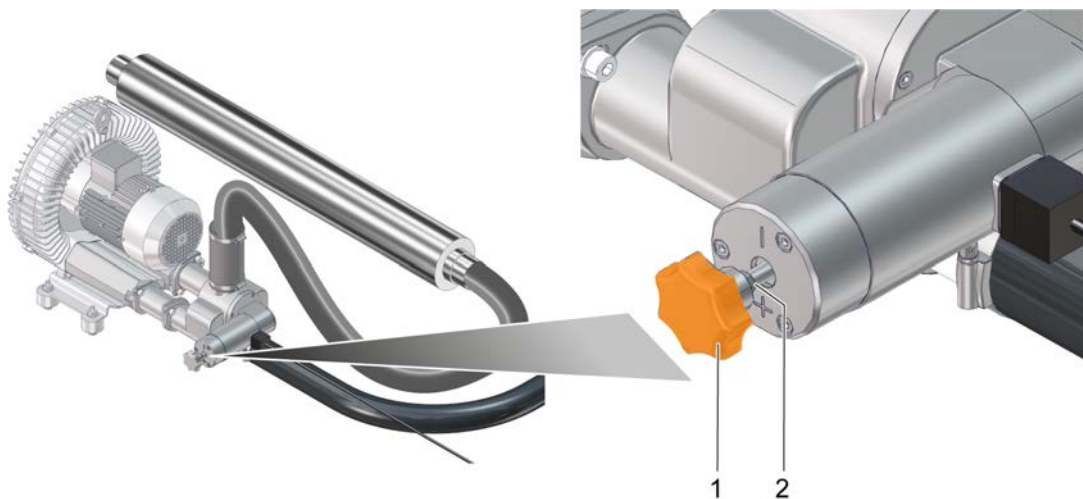

- 1 Knob
- 2 Lock nut

A Establish access to the vacuum pump.

B Loosen the lock nut on the knob.

C Set the air flow for the air cushion:

Option

Material is not lifted strongly enough

Material is lifted too much

Description

Turn the knob to the left

Turn the knob to the right

D Tighten the lock nut.

4.16 Integrated Tool Initialization - ITI

The tool is initialized via permanently installed, automatic initialization system. The ITI is installed on the machine as standard, either to the left or right of the working surface. A second ITI can be additionally installed as an option.



- 1 ITI left (initialization of the tools in slots 1, 2)
- 2 ITI right (initialization of the tools in slots 2, 3)

4.16.1 Important menu settings

General settings

Menu	Setting
1-1-1-2-2 Auto init	Initialize active tool with ITI
1-1-1-2-3 Up Z pos	Enter the up position
1-1-1-2-4 Down Z pos	Enter the down position
1-6-3 additional underlay	Switch ON/OFF whether an additional underlay is being used.

Set the height of the cutting base

Menu	Setting
1-9-4-1-1 Thickness	Enter the thickness of the cutting base.
1-9-4-1-2 Calibration	Determine the height of the cutting base.

Set the height of an additional base (routing base)

Menu	Setting
1-9-4-3-1 Thickness	Enter the thickness of an additional extra cutting base.
1-9-4-3-2 Calibration	Determine the height of the cutting base.

4.16.2 Initialization process

During initialisation, the tool tip (e.g. blade) is set to the exact height of the cutting board surface. This position serves as basis to determine the cutting depth (**down position**) and the tool position in raised state (**up position**).



1-1-1-2-2 Auto init

Using ITI, the tip of the tool insert is set exactly to the height of the working surface (cutting/routing underlay). This value serves as a starting point for setting **the up position** and **the down position**.

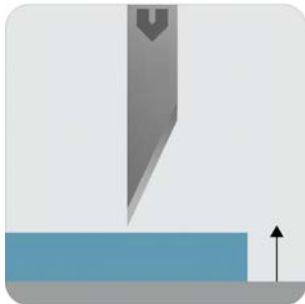

1-1-1-2-3 Up Z pos

The **upper position** defines the gap between the zero point and the raised tool. Select this value in accordance with the material and its folding properties. A short gap between processing material and raised tool generally means a shorter processing time.

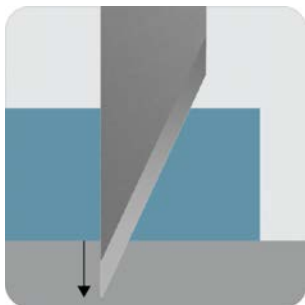

1-1-1-2-4 Down Z pos

Down position defines the cutting depth of the tool into the cutting/routing supports. This is necessary in order to cut completely through the processing material. Down position is dependent on the processing material and the processing method.



1-1-1-2-6 Test cut

Always perform the test cut with the processing material and the processing parameters of the original job. If the processing material is not completely cut through, change the **down position**.

4.16.3 Automatic initialization



Note:

Risk of damage to the cutter and tools!

- Use the ITI for compatible tools only.
- For more information, consult the operating manual of the relevant tool.



Tip:

By starting the automatic initialization function, the active tool automatically moves to the correct ITI:

- Modules/tools in slot 1: ITI left
- Modules/tools in slot 2: ITI left or right (the closest ITI will be moved to)
- Modules/tools in slot 3: ITI right

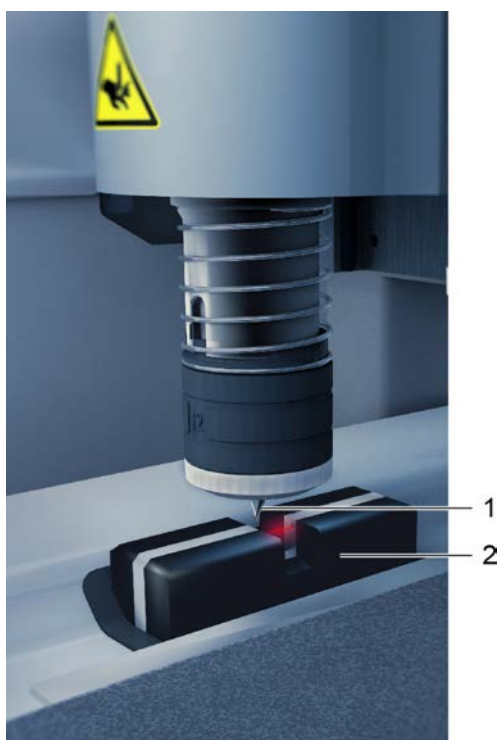

1 Knife

2 ITI

A Select the function for automatic initialization with **1-1-1-2-2 Auto init.**

B Select **OK** to confirm.

Results

The tool is positioned via the ITI and the initialization process is started. After initialization, the tool is precisely initialized to the height of the cutting base. The value that is determined is saved for the specific tool.

4.16.4 Calibrating the cutting board

To achieve perfect results, the thickness of the used cutting board must be calibrated. Calibration is necessary under the following circumstances:

- Wear on the cutting board.
- When using a new cutting board.

If a second board is used, for example for routing, this additional underlay must also be calibrated ([Use of additional underlay](#) on page 127).



Tip:

Remove the gliding shoe of the tool used before calibrating the cutting board.

4.16.4.1 Calibrating the cutting board

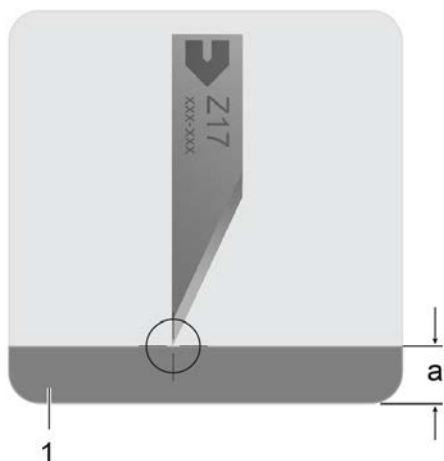

1 Cutting board

a Base height

A 1-9-4-1-2 Calibration select.

B The assistant to set the thickness of the cutting board starts.

C Follow the assistant's instructions.

4.16.4.2 Use of additional underlay

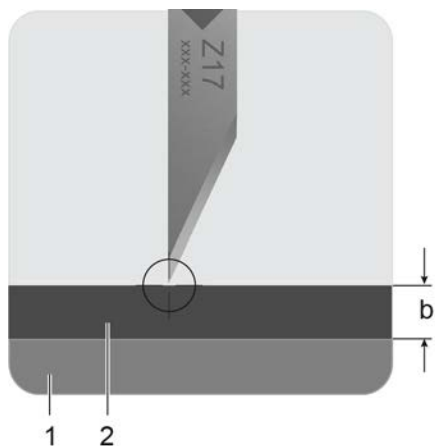

- 1 Cutting board
- 2 Additional underlay (e.g., routing underlay)
- b Height of additional underlay



Tip:

Use the tool to calibrate the additional underlay with which it is used.

- A** Place the additional cutting board on the working area.
- B** Activate the additional cutting board with **1-6-3 additional underlay**.
The additional cutting board is activated in the system.
- C** **1-9-4-3-2 Calibration** select.
- D** The assistant to calibrate the thickness of the extra cutting board starts.
- E** Follow the assistant's instructions.

Results

The additional cutting board is calibrated.

- Remove the additional cutting board after working with it.
- Deactivate the additional cutting board with **1-6-3 additional underlay**.

4.17 Automatic Router Bit Changer ARC / ARC HSK (optional)

The ARC / ARC HSK magazine simplifies tool handling and leads to a significant increase in the quality and cost-effectiveness of the routing process.

The magazine can accommodate the router or collet chuck. The required routers are automatically moved, clamped, initialized and cleaned. The time required for replacing routing tools is thus significantly reduced. The Zünd Cut Center software automatically detects the operating time of the router used.

A cleaning station is integrated on the magazine at which each router can be cleaned with compressed air. During routing, the magazine is automatically lowered and sealed with a magazine flap to prevent contamination.

Whether to use ARC or ARC HSK depends on the router module used:

Router module	ARC	ARC HSK
RM-A	X	
RM-L		X

Additional and more detailed information can be found in the ARC / ARC HSK operating instructions under section 10 (additional description).

4.18 Job processes

4.18.1 Tandem operation (optional)

Important:

Tandem operation is only available if the cutter is fitted with the tandem vacuum system option.

In addition to the *vacuum zones*, the vacuum plate is subdivided into two front and rear sections, which act independently of one another.

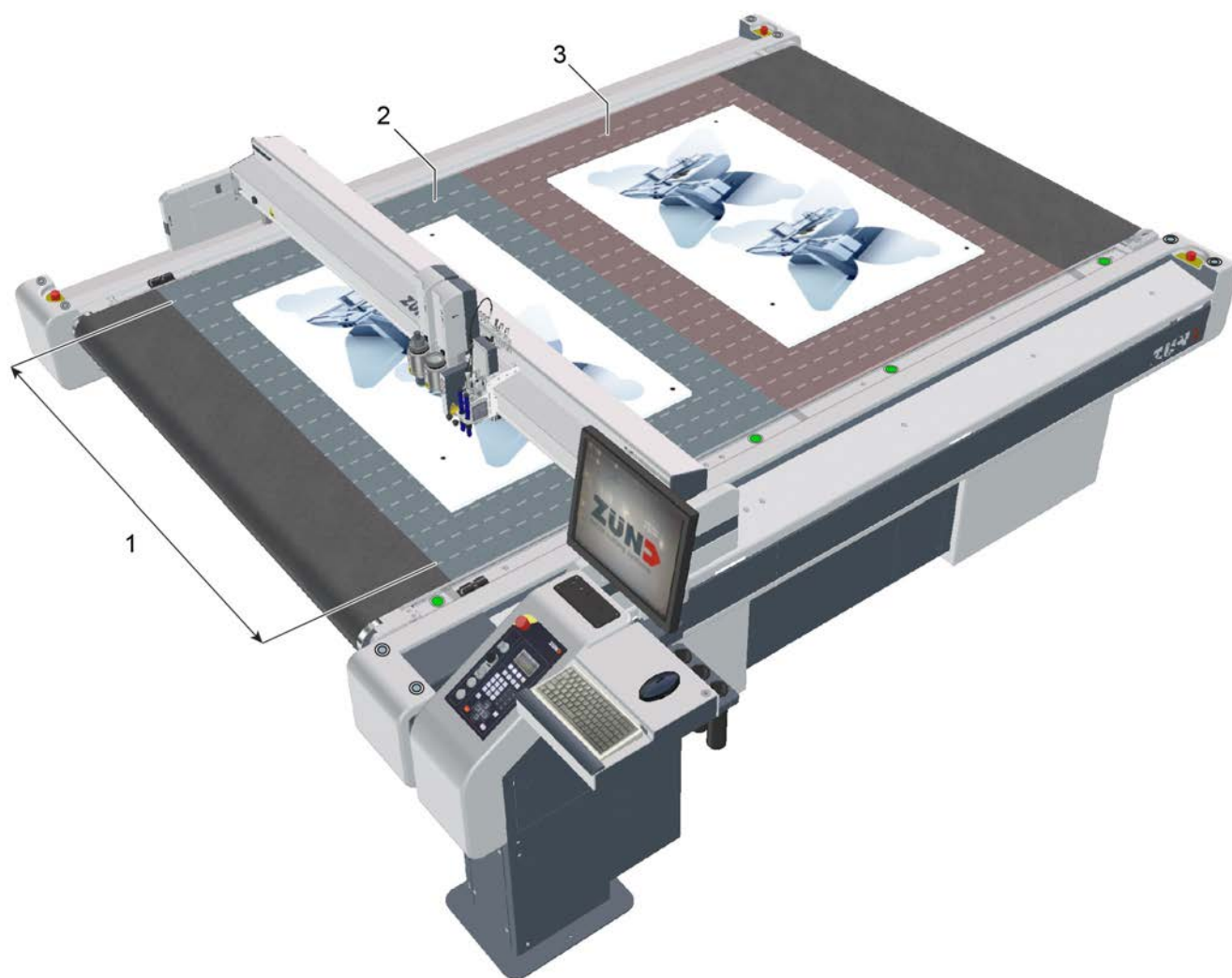

- 1 vacuum zones,
- 2 Front workspace
- 3 Rear workspace

4.18.1.1 Menu settings

Menu	Selection	Function
1-7-8-1 Tandem	Off	No job process selected.
	Tandem operation	Selection of tandem operation job process.
3-1-1 Tandem system		
3-1-1-1 Front status	-	Indicates whether switched off in front working area or whether a vacuum or an air cushion is present.
	-	Switch on the vacuum/air cushion for the front working area.
1-6-1-1-1 Front off	-	Switch off the vacuum/air cushion for the front working area.
1-6-1-1-1 Front vacuum	-	Vacuum pre-selection
1-6-1-1-2 Front air cushion	-	Air cushion pre-selection
3-1-1-4 Rear status	-	Indicates whether switched off in front working area or whether a vacuum or an air cushion is present.
	-	Switch on the vacuum/air cushion for the rear working area.
1-6-1-1-4 Rear off	-	Switch off the vacuum/air cushion for the rear working area.
1-6-1-1-4 Rear vacuum	-	Vacuum pre-selection
1-6-1-1-5 Rear air cushion	-	Air cushion pre-selection

4.18.1.2 Controls, description

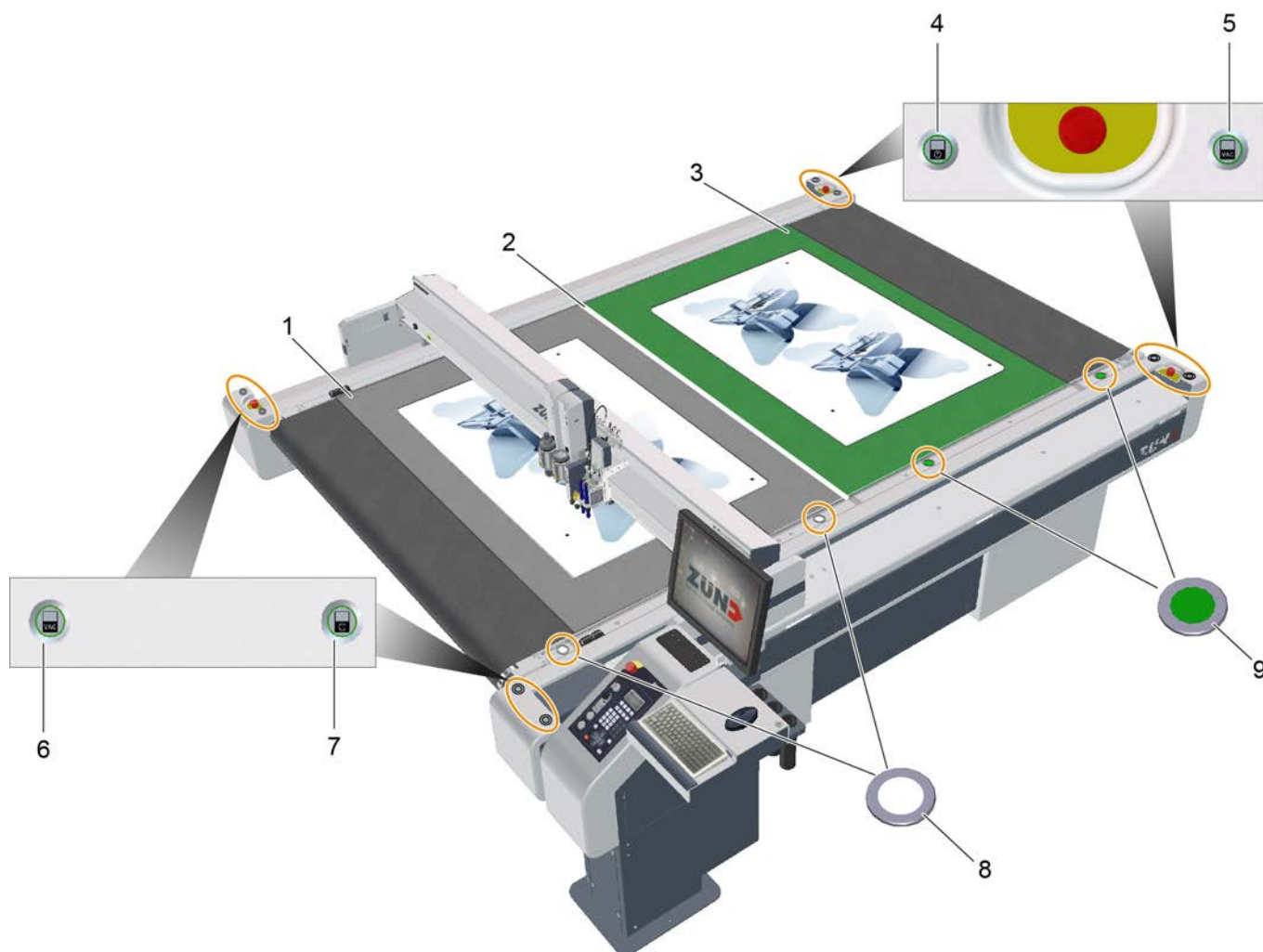

- 1 Front working area
- 2 Center of table
- 3 Rear working area
- 4 Key: rear processing approval
- 5 Key: switch on rear vacuum
- 6 Key: switch on front vacuum
- 7 Key: front processing approval
- 8 Signal: loading/unloading front working area possible/not possible
- 9 Signal: loading/unloading rear working area possible/not possible

Switch vacuum on/off



The key lights up when the vacuum for the working area is switched on.



The vacuum for the working area is switched off.

On the loading/unloading side, the vacuum can be switched on after loading so that the processing material is fixed in place after being placed on the working area. The key lights up when the vacuum is switched on.



Note:

If processing approval has been given before the vacuum is switched on, this automatically takes place before processing.

Processing approval



The key is lit when the processing approval has been granted. As soon as processing is finished in the other working area, the working surface for which approval has been granted will be processed.



No approval granted.

After loading, press the processing approval key. This indicates to the cutter that the material is correctly positioned and that processing can be started.

Signals, loading/unloading possible



The working area is approved for loading/unloading.



Processing approval has been granted for the working area or processing is currently taking place.

The signals are installed on both working areas. When the signals for a working surface light up green, material can be loaded and unloaded on this working surface.

4.18.1.3 Tandem operation

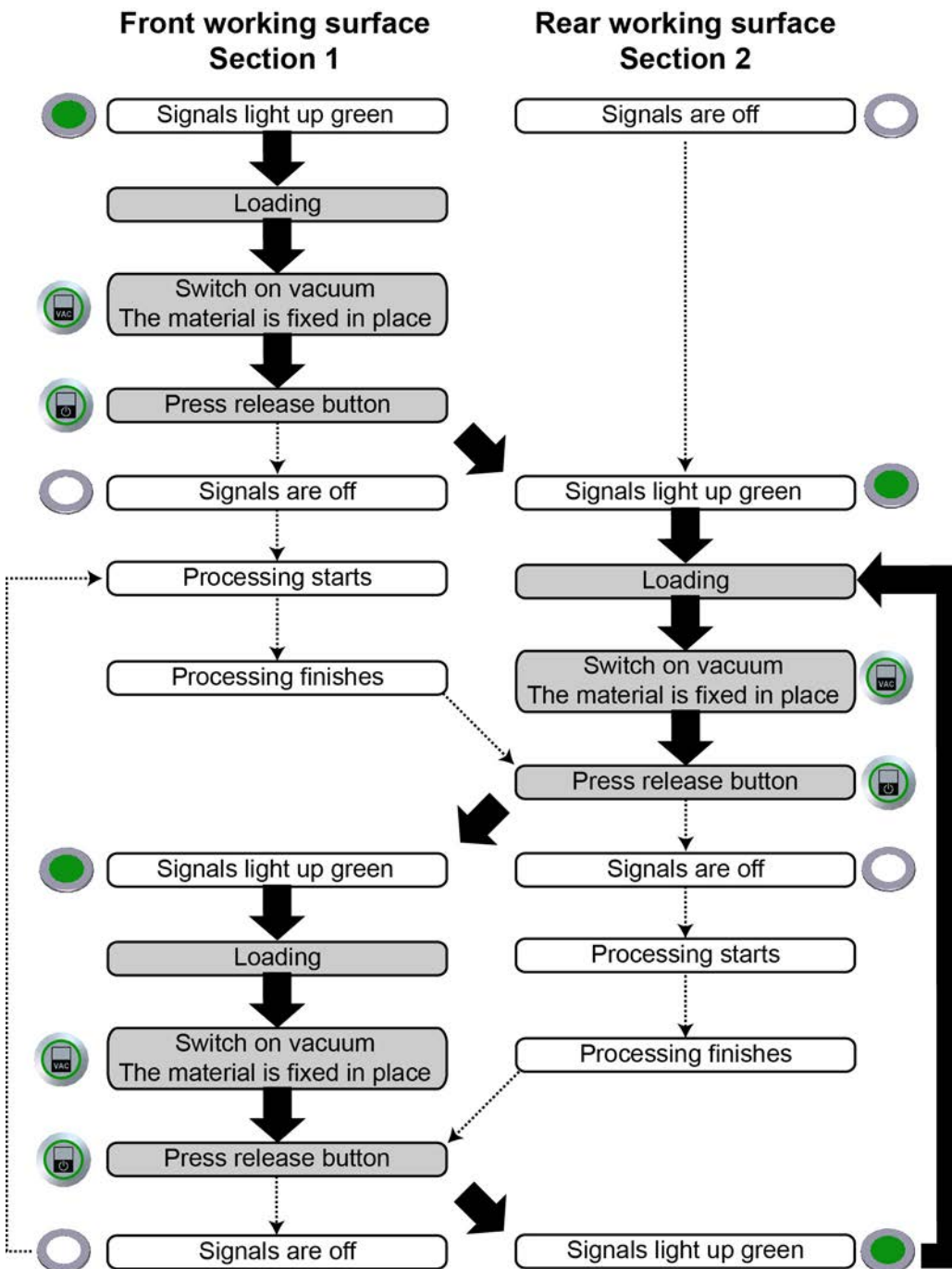

4.19 Laser pointer, reference point

4.19.1 Laser pointer

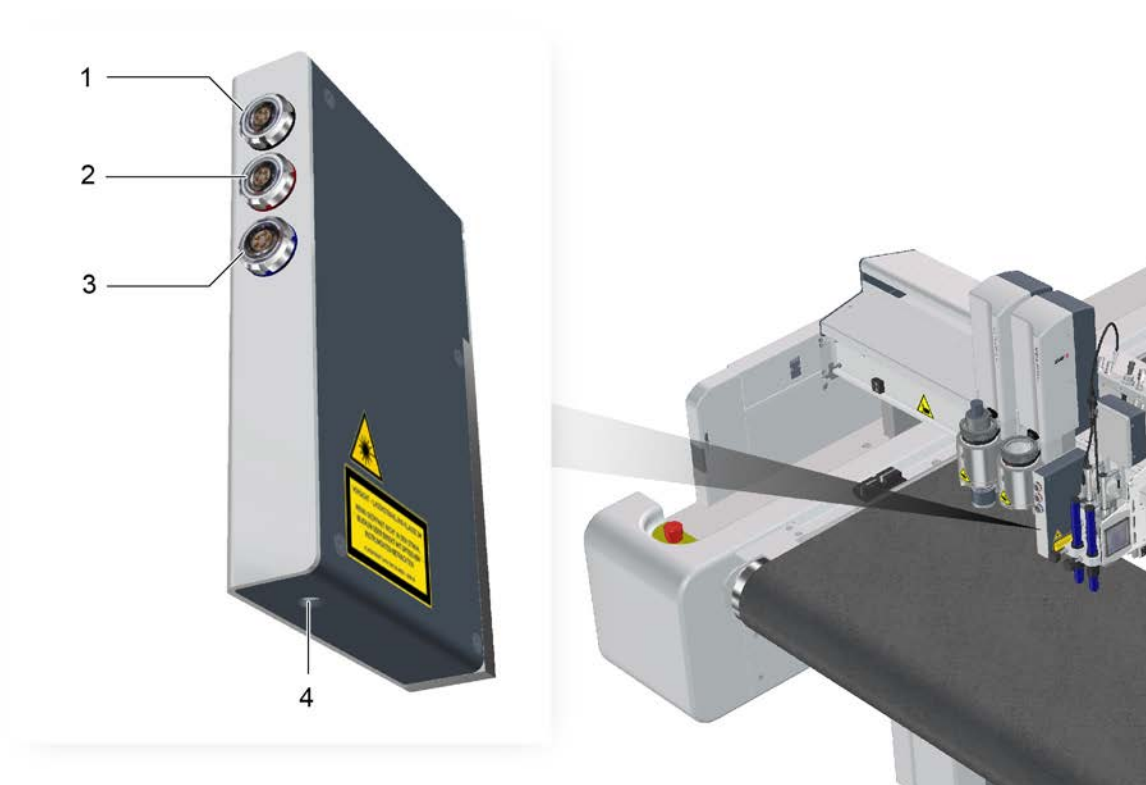

- 1 Connection 1 - port 1¹
- 2 Connection 2 - port 2¹
- 3 Connection 3 - port 3¹
- 4 Laser pointer exit

¹See [Connecting powered tools](#) on page 104.

4.19.2 Pointer selection

Optionally, either the current tool or the laser pointer can be set as the pointer. The position of the pointer is used to define, for example, the reference point or the vacuum width.

- A** Select the **1-5-2-1-1 Pointer type** function.
- B** Select the laser pointer or tool.

Results

The pointer is selected and active.

4.19.3 Reference point

A reference point can be defined on the processing surface of the cutter.

This reference point is the starting point for the processing procedure and corresponds to the zero point of the processing file.

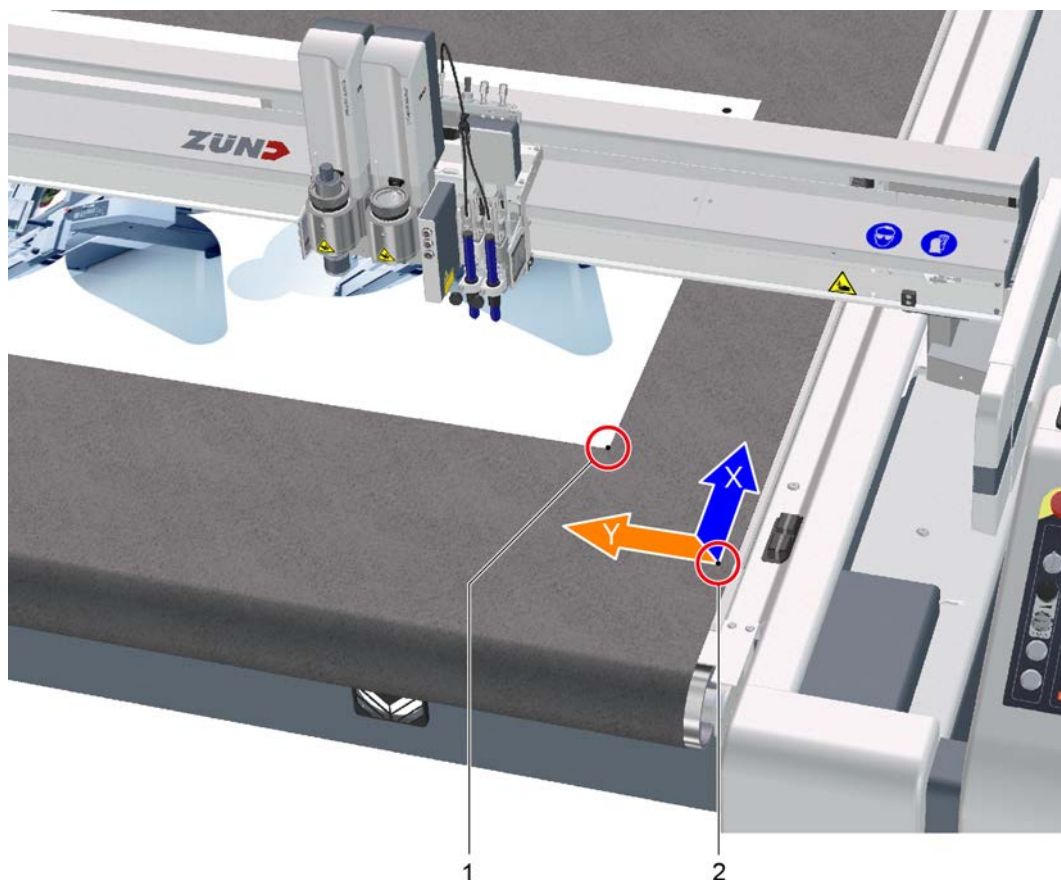

- 1 Reference point
- 2 Zero point X/Y axis, cutter

4.19.3.1 Defining a reference point

A Select **2-1-1-3 Define a reference point**.

B Use the travel keys to place the above the desired reference point on the working surface.

C Confirm with **OK**.

Results

The reference point is saved for the duration of time that the cutter is switched on. This reference point now applies as the starting point for the processing of material.

4.20 ICC camera, automatic registration (optional)

4.20.1 ICC camera



- 1 Connection 1 - port 1¹
- 2 Connection 2 - port 2¹
- 3 Connection 3 - port 3¹
- 4 Fixing screw
- 5 Stop
- 6 Laser beam exit
- 7 Camera lens

¹See [Connecting powered tools](#) on page 104.

4.20.2 Registration marks

The ICC camera is used to determine the position of printed material on the processing surface using software. The material has the same registration marks as those in the processing file. Recording of the registration marks is software-dependent.

**Tip:**

When using the ZCC software register, marks with a diameter of 6 - 8 mm 0.2 - 0.3 in are recommended for use.

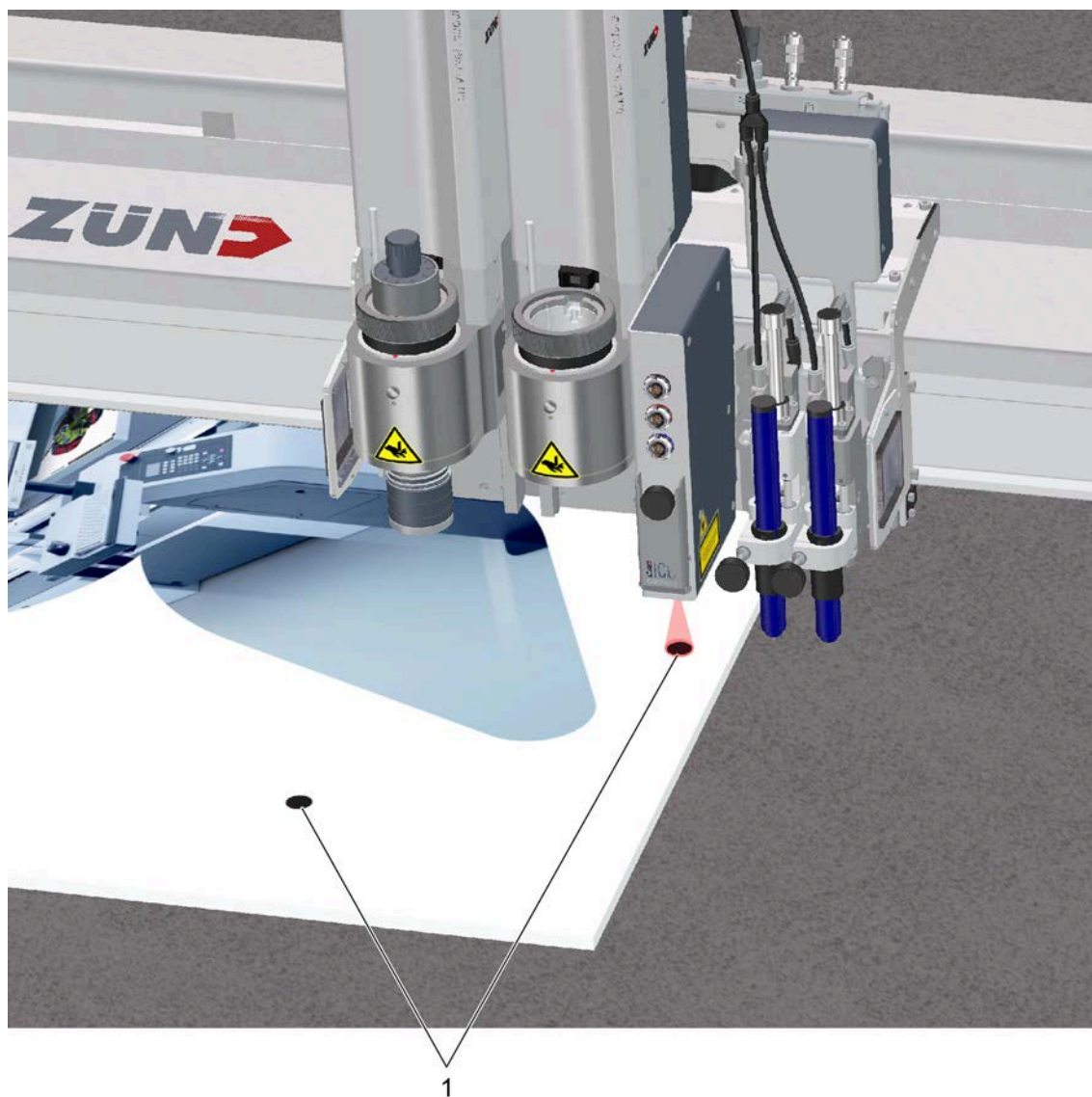

1 Registration marks

Registration mark requirements in case of reflective materials

Color - the image evaluation in the front end software can also use the color to detect the registration mark, along with the shape.

Diameter - So that the reflective camera lens is not detected as a registration mark, the diameter of the registration mark should be selected larger than 17 mm 0.7 in or smaller than 14 mm 0.5 in.

4.20.3 Setting the ICC camera position

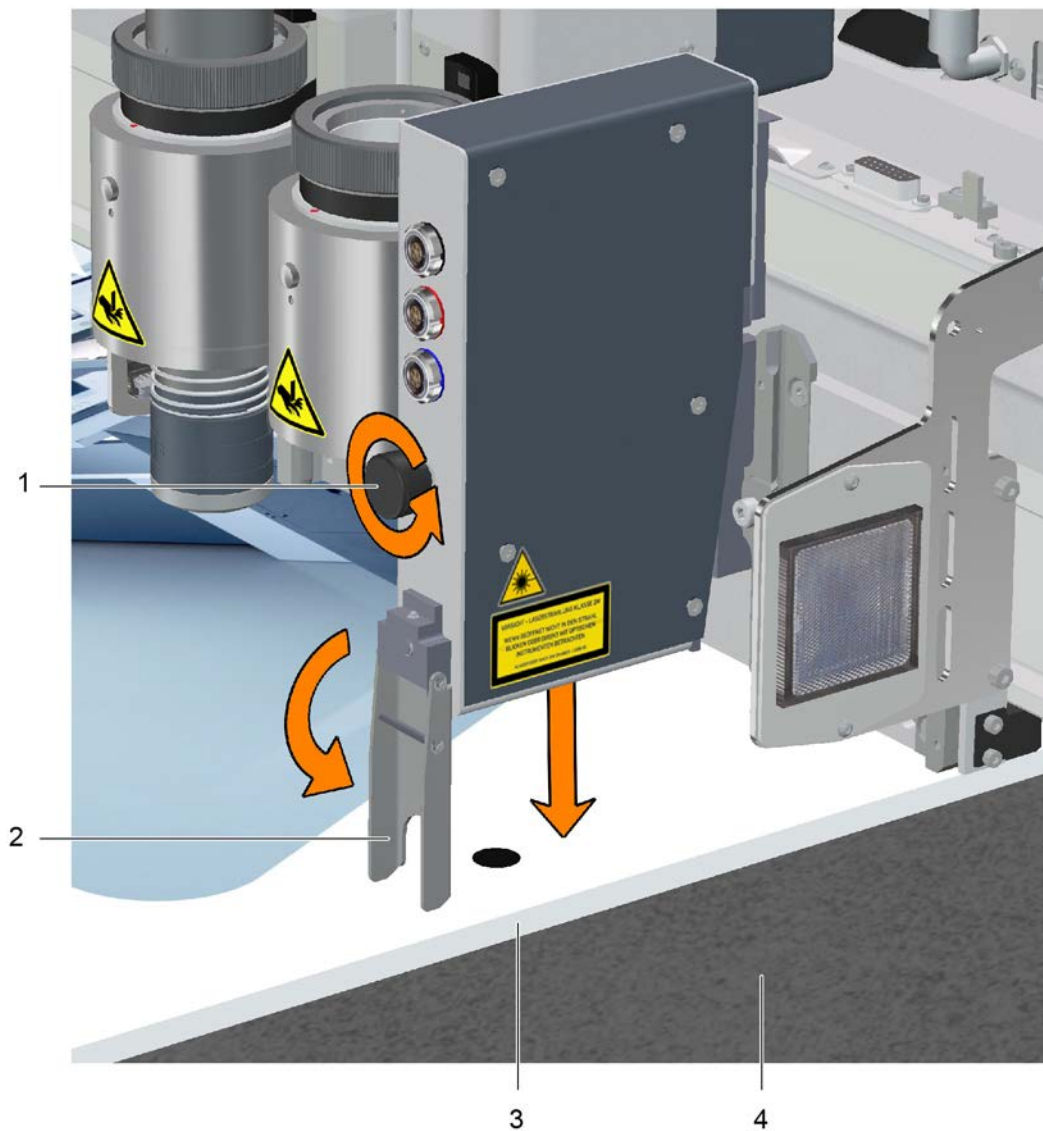

- 1 Fixing screw
- 2 Spacer
- 3 Material
- 4 Cutting board

- A** Open the spacer.
- B** Untwist the fixing screw.
- C** Lower the ICC camera until the stop.
- D** Twist the fixing screw.
- E** Close the spacer.

4.20.4 Adjusting ICC camera 120 mm clearance

On a cutter with a 120 mm clearance, the spacer bar cannot be folded down. An adjusting gauge is therefore required for adjustment.

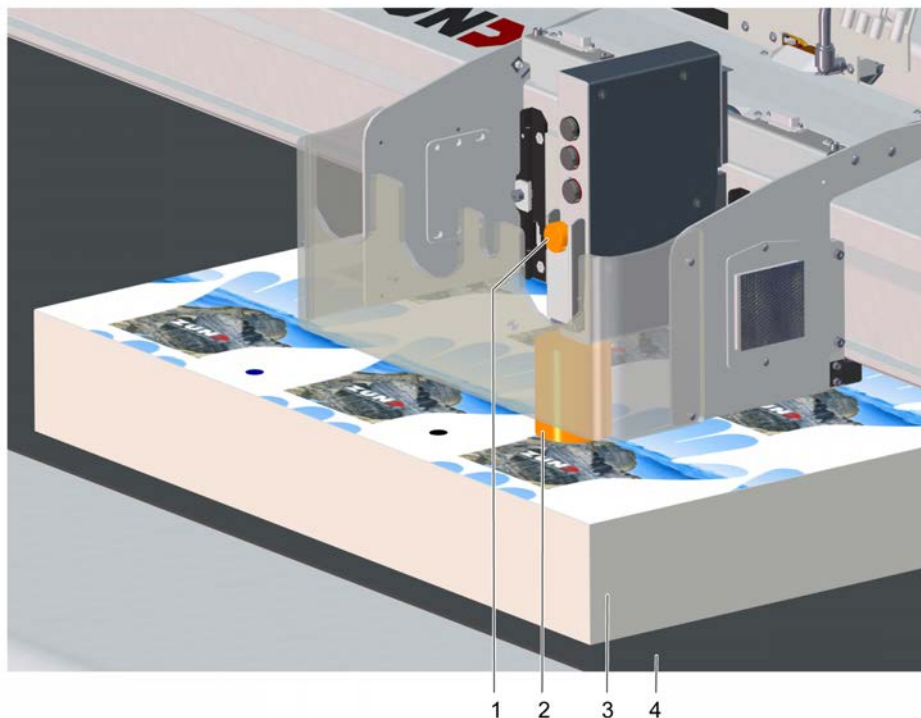

- | | | | |
|---|-----------------|---|---------------|
| 1 | Fixing screw | 3 | Material |
| 2 | Adjusting gauge | 4 | Cutting board |

- A** Place the material.
- B** Place the adjusting gauge on the material
- C** Move the ICC camera over the adjusting gauge.
- D** Loosen the fixing screw.
- E** Lower the ICC camera until the ICC camera touches the adjusting gauge.
- F** Tighten the fixing screw.
- G** Remove the adjusting gauge.

4.21 Module carriage slot protective plate



Warning:

Crushing risk!

The module carriage area is not monitored by safety devices.

- Do not reach into the active area of the cutter during operation.
- Protect non-occupied slots with slot protective plates.

On the one hand, the slot protective plate is used as a safety device, and on the other it is used to protect a free module slot from contamination.

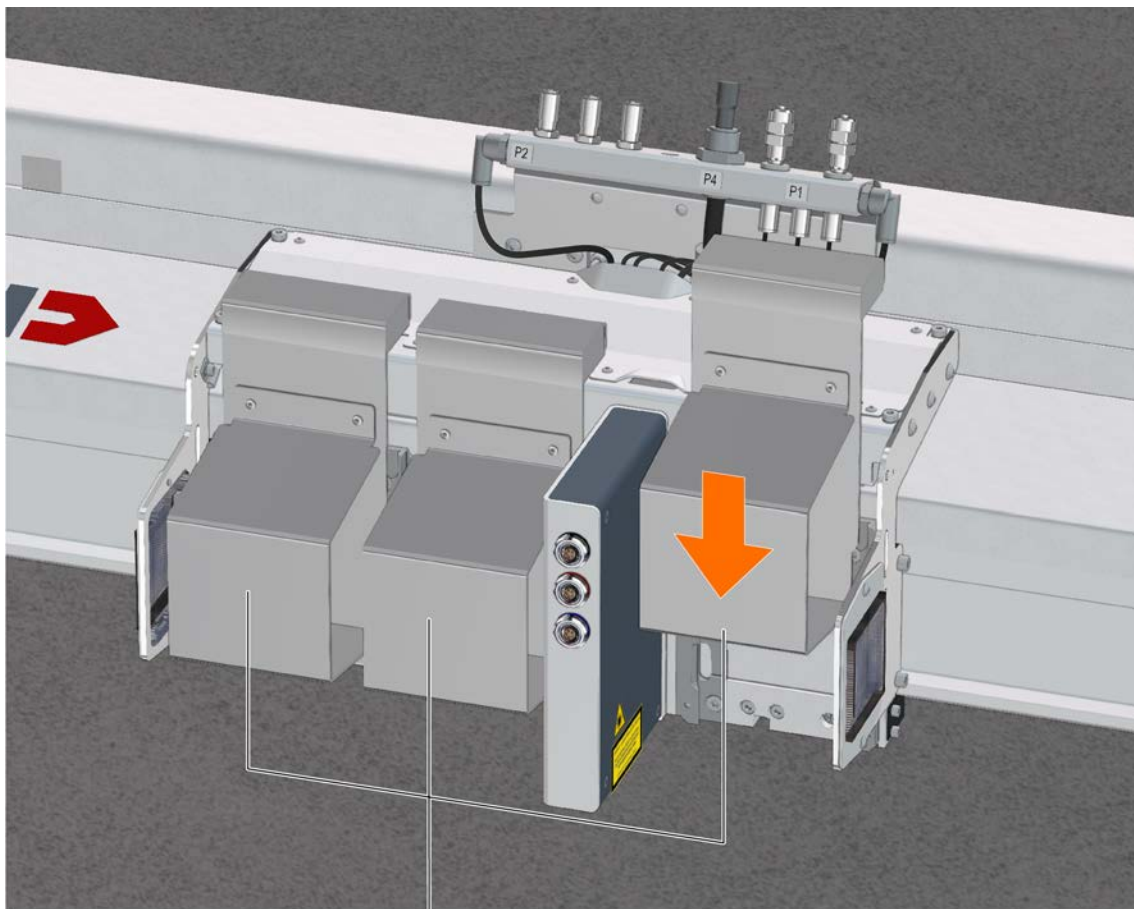

1

1 Slot protective plates

4.22 Signal lights (optional)

Signal lights are used to visually indicate the cutter's operating status, warnings and any errors.



Signal color	Operating state/meaning/effect	
Red	STOPPED	Cutter stops
	Error	
Yellow	OFFLINE	Cutter stops
	Warning	Machining continues; a warning appears on the operating unit
Green	ONLINE	-
Blue	<ul style="list-style-type: none"> User action required on control panel. User action in Zünd Cut Center required. 	

4.23 Module and tool holder (optional)



Note:

Always store unused tools and modules correctly in order to avoid damaging them.

Store any unused modules and tools in the module and tool holder. The module and tool holder has space for two tools and modules.

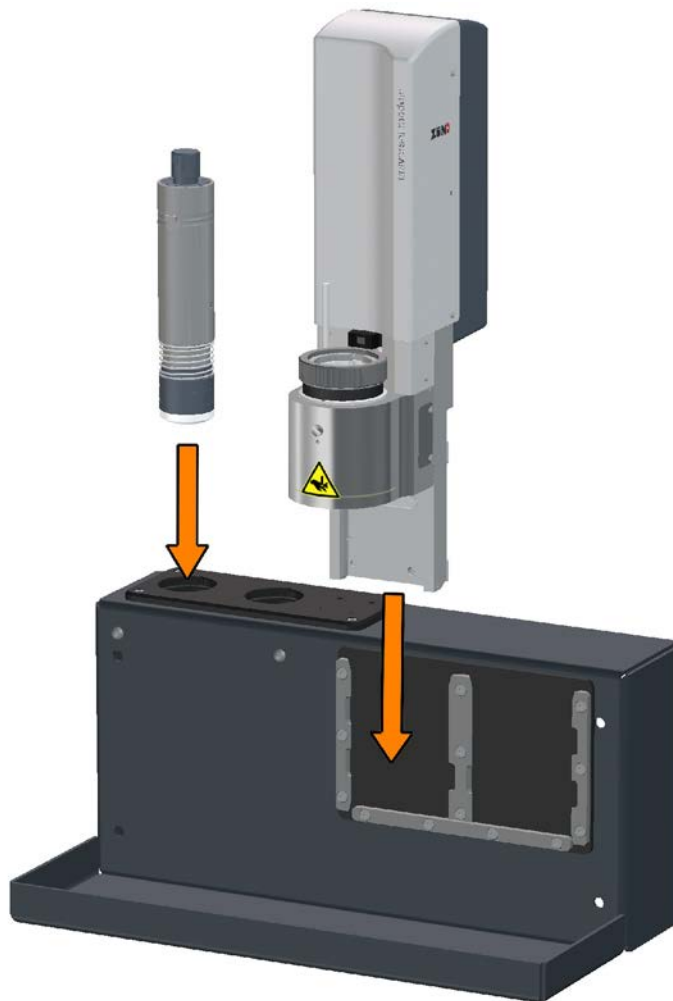

5 Tips for cutting

Efficiency and production quality can be affected by many factors. If you are not satisfied with the quality of your job, the following questions can help:

- 1 Can the tool used cut the material?
- 2 Can the blade used cut the material?
- 3 Is the blade of high quality?
- 4 Have the cutting data been processed in a way appropriate for the cutter?
- 5 Have settings such as speed or acceleration been selected correctly in relation to the processing method and processing material?
- 6 Is the material adequately fixed, are the vacuum settings correct?



Tip:

Contact your Zünd partner or the Zünd customer information centre for further information.

5.1 Select tool



Tip:

Zünd recommends using Zünd Cut Center - ZCC as the processing software. The ZCC material database contains a multitude of materials, the optimum processing methods and the processing parameter required for it.

Each material possesses specific properties that have to be observed during processing. The Zünd modular tool concept offers the right processing method for every material:

- Processing with drag knives (UCT, SCT, VCT, PPT, KCT)
- Oscillating cutting (EOT, EOT-250, POT)
- Processing with rotating knives (DRT, PRT, WKT)
- Routing (URT, RM-A, RM-L)

5.2 Selecting a blade

5.2.1 Knife types

Depending on which tool the knife is used in, a distinction is made between the following knife types:

- **Drag knife:** this knife is used in non-powered tools such as UCT, VCT, SCT, PPT, KCT, KCM-S
- **Oscillating knife:** used in EOT, EOT-250, POT oscillating tools
- **Rotary knife:** decagonal (ten-sided) blades for DRT, PRT tools
- **Circular knife:** used in WKT tool

5.2.1.1 Drag knife

Drag knives are used in combination with non-powered tools (UCT, SCT, PPT, VCT, KCT,...).

- Maximum processing speed
- Cheap to purchase and maintain
- High cutting force
- Particularly suitable for foils, paper, thin folding carton, banners, etc.
- Most cost-effective processing variant, as the purchase price for the required tools is significantly lower compared to powered tools.

Round-shaft knife (e.g., Z1)



Flat-shaft knife (e.g., Z10)



Passepartout knife (e.g., Z34)



V-cut knife (e.g., Z70)



5.2.1.2 Oscillating knife

The oscillating tool is mostly recommended for cutting thick and tough materials. The oscillating motion of the blade decreases the drag force exerted on the material in the direction of travel. However, to achieve this, the feed speed must be precisely adjusted to suit the blade geometry and the oscillation frequency of the tool used. Choosing the right oscillating knife depends primarily on the processing contour to be cut:

- Zünd recommends flat blades for large radii, straight and large parts.
- Very sharp, pointed blades should only be used to cut small radii. The feed speed must be reduced to achieve a good quality cut!

Flat knife (e.g., Z43)



- High processing speed
- Large radii, straight or large parts

Pointed knife (e.g., Z20)



- Low processing speed
- Small radii or small parts

5.2.1.3 Rotary knife

Decagonal (ten-sided) knife (e.g., Z50)



- Very high processing speed
- Suitable for large radii, straight or large parts
- Recommended for breathable materials such as textiles, carbon fiber, glass fiber, etc.
- Very large overcut

5.2.1.4 Circular knife

Circular knife (e.g. Z55)



- Very high processing speed
- Suitable for large radii, straight or large parts
- Recommended for breathable materials such as textiles, carbon fiber, glass fiber, etc.
- Very large overcut
- Only use with special PU cutting board.

5.2.2 Blade geometry

5.2.2.1 Wedge angle

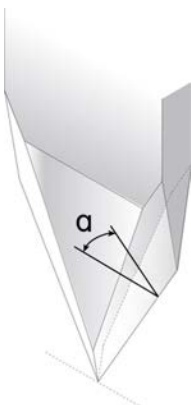

The wedge angle determines the sharpness of the blade. In theory, a very narrow wedge angle means a very sharp blade that exerts very little drag force on the material. However, a narrow wedge angle also results in considerable force being exerted on the blade. The narrower the wedge angle, the more unstable the blade becomes. For this reason, the wedge angle is always a compromise between

sharpness and stability. Zünd blades are specifically designed and sharpened to handle a wide range of materials. The additional specifications provided for each blade contain a list of the materials for which it can be used.

5.2.2.2 Cutting angle

The cutting angle has a major effect on the cutting force. With drag knives, a narrow cutting angle means smaller drag forces. However, this has the disadvantage of creating a larger overcut.

Drag knife



Oscillating knife, flat



Oscillating knife, pointed



5.2.2.3 Maximum cutting depth

There is a specified maximum cutting depth for each blade, which is determined by the length of the cutting edge. The cutting depth which can be achieved depends greatly on the type of material. The cutting depth of some oscillating blades will be reduced when using the spring-loaded glide shoe. Please remember to factor in the set depth as well as the material thickness.

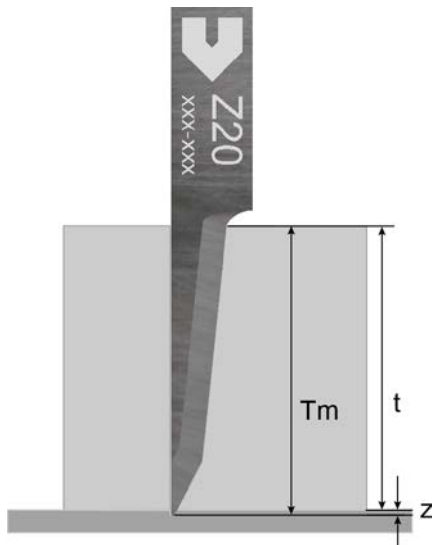

T Material thickness

Z Set depth

TM Cutting depth = material thickness t + set depth z

5.2.2.4 Overcut

The pre-cut x_1 is the distance from the centre of the axis of rotation to the first point where the cutting edge cuts the material surface in the direction of travel. The post-cut x_2 is the measurement from the centre of the axis of rotation to the last point where the cutting edge cuts the material surface.

The cutting angle has the greatest influence on processing quality. A narrower cutting angle may enable a faster processing speed, but it also produces a greater overcut. A narrower cutting angle can be used for paths that include large curves and long straight sections.



Tip:

The overcut distorts the cutting paths. For cuts with a low margin of error, Zünd recommends choosing a knife with a lower overcut. Overcut information can be found in the additional specifications for each knife.

Drag knife

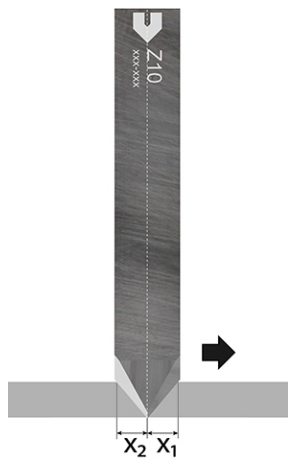

Oscillating knife, flat



Oscillating knife, pointed



5.2.2.4.1 Calculating the overcut

Depending on the cutting depth, the blade geometry will produce a different level of overcut. This chapter explains how to calculate your overcut based on the blade you are using and the material you are cutting. The Z20 pointed oscillating knife and Z11 drag knife are used as examples here.

The cutting depth TM is made up of the material thickness t and the set depth z . Insert these values into the formula as they are listed in the product description for each blade. The result will be the pre-cut/post-cut in mm.

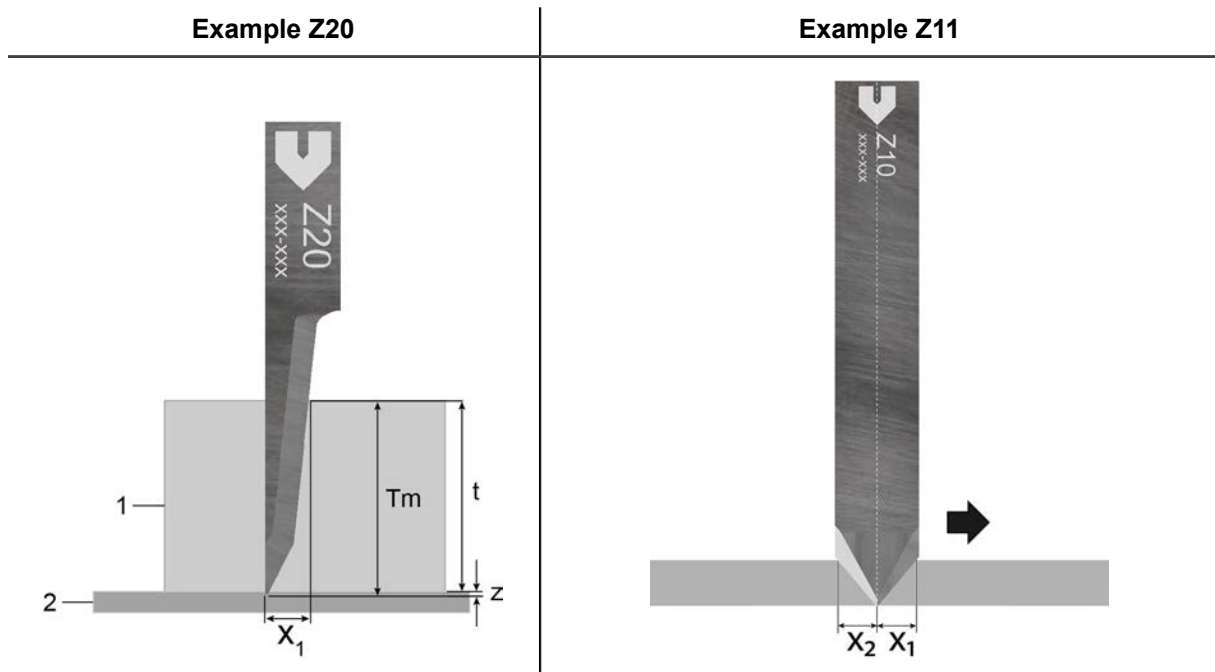

- 1 Material
- 2 Cutting board
- T Material thickness
- Z Set depth
- TM Cutting depth = material thickness t + set depth z
- x₁ Pre-cut
- x₂ Post-cut

	Sample calculation Z20	Sample calculation Z11
Formula	$x = 1.2 + 0.11 \times TM$	$x_{1,2} = 0.58 \times TM$
Cutting depth	TM = 10.2 mm	TM = 5.2 mm
Pre-cut	x ₁ = 2,322 mm	x ₁ = 3,016 mm
Post-cut		x ₂ = 3,016 mm

5.3 Preparing cutting data



Tip:

Zünd recommends using Zünd Cut Center - ZCC as the processing software. The data are optimally prepared for the requirements of Zünd cutters.

If the front end software sends the curves to the cutter in the form of arc functions, the cutter control unit generates the resolution automatically according to the quality level set. This helps the user to adjust the cutter and leads to high quality processing results.

5.4 Settings, speed, quality

The output of the cutter and the quality of the cutting result are effected by the acceleration, quality, and speed selected.

5.4.1 Quality and acceleration

Above all, the output quality is defined by the quality and acceleration settings.

- If a high quality is required, it is recommended to select quality level 1 (high). If the result is still not satisfactory, the acceleration can additionally still be reduced from 4 to 3, 2, or 1.
- If the quality is less important, then quality level 3 (low) and acceleration 4 (max.) can be selected (in favor of maximum productivity).
- By default, quality level 2 (normal) and acceleration 4 are set. In most cases, this provides good quality with high productivity.

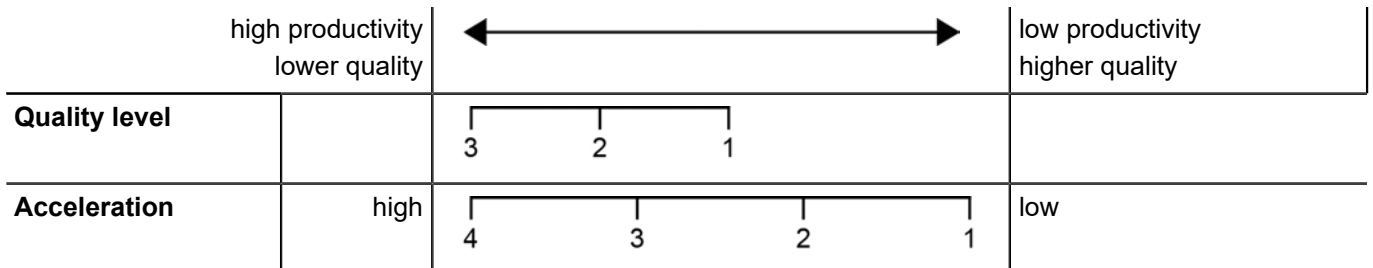

5.4.2 Speed

The speed only has a limited effect on the quality of the cutting result. That is why it should be limited only if the cutting or routing process requires it.

The maximum speed that can be reached depends on the cutting contour. High speeds can only be reached in sufficiently long straight sections or sufficiently wide radii. If the cutting or routing process allows it, it is recommended to leave the maximum speed at 1 m/s.

If the cutting process requires a very low speed and the radii are not too tight, a reduction of the speed is recommended.

Recommended acceleration level depending on the speed

Speed [mm/s]	Acceleration level
10	1
20	1
40	2
80	3
> 160	4

5.5 Recognising processing errors

5.5.1 Blade clamped at an angle



If the blade does not lie exactly at the zero point, a cut is produced that runs parallel to the original cutting path.

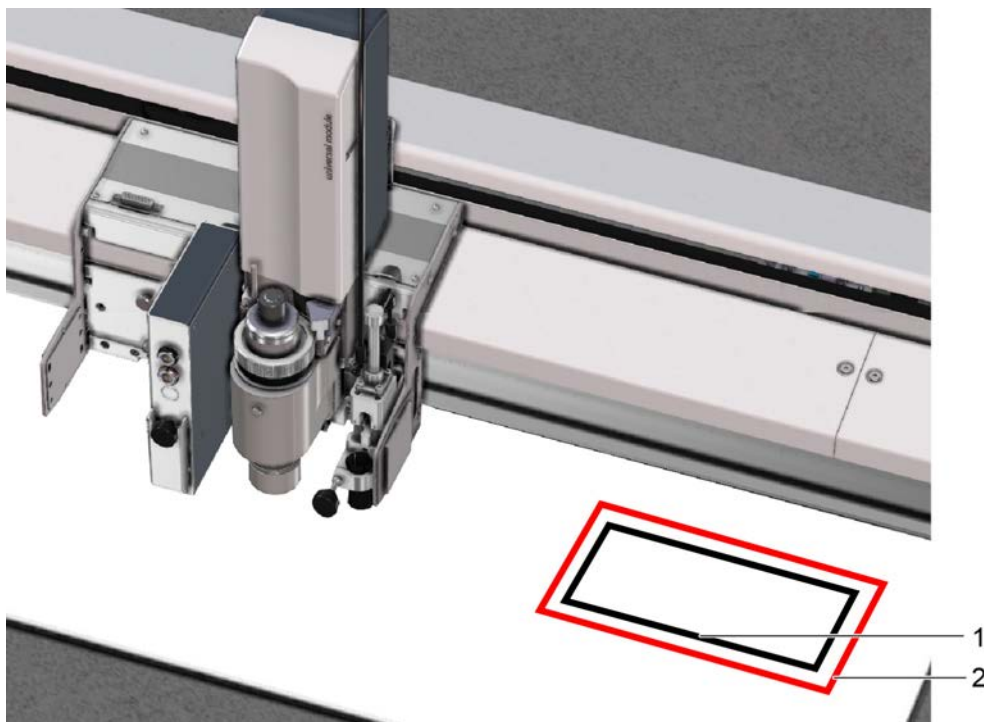

- 1 Contour as per processing file
- 2 Effectively cut contour due to blade clamped at an angle
- Y1 Deviation of the blade to zero point

5.5.2 Blade displaced from turning center

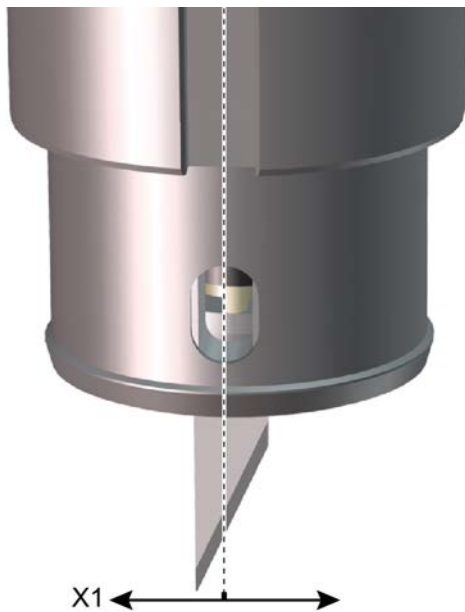

If the blade tip is not positioned in the turning centre of the tool, the rotational axis of the blade will be displaced. This results in the following quality defects:

- The start and end point of the cutting path do not match up
- Curves are cut inaccurately

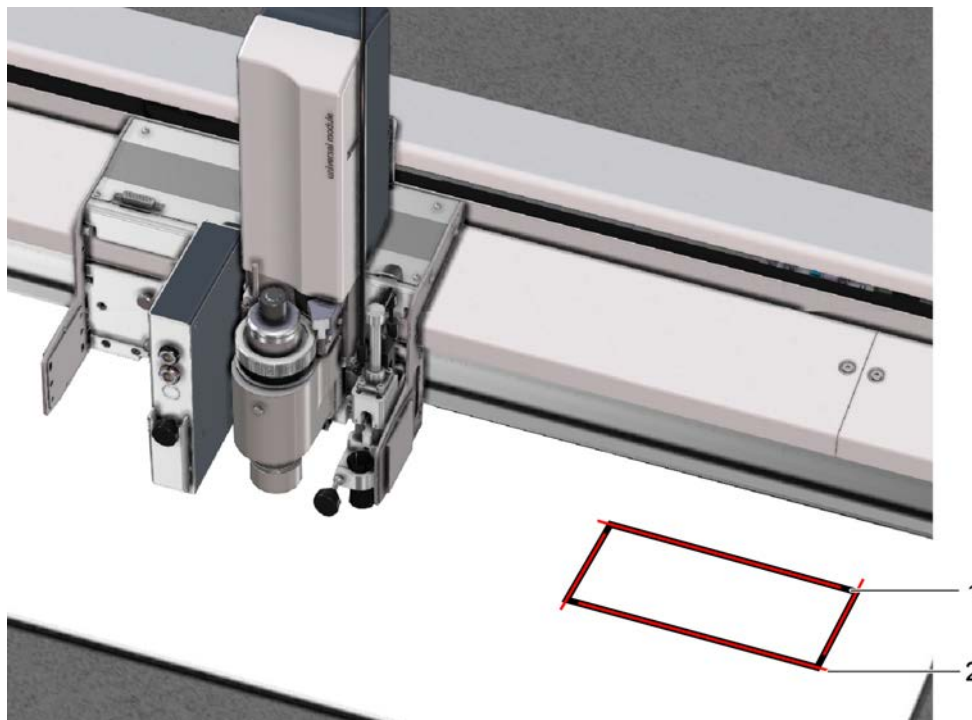

- 1 Contour as per processing file
- 2 Effectively cut contour due to blade displaced from the turning center
- X1 Deviation of the blade to the turning center

5.5.3 XY correction

Slight inaccuracies when clamping the blade can be corrected using the XY correction.

Correction values, general

The penetration point and/or the cut direction of each test cut act as measuring points for the calculation of the correction values. You should therefore observe exactly where the blade penetrates when cutting the 4 lines and mark the penetration points.

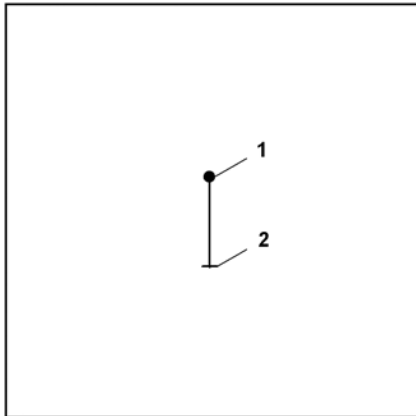

1 Start of cut (penetration point)
2 End of cut

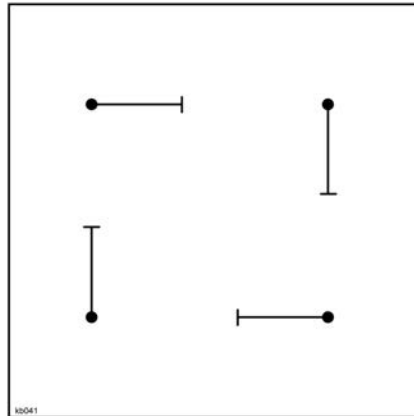

Cutting diagram with all correction values set to 0.

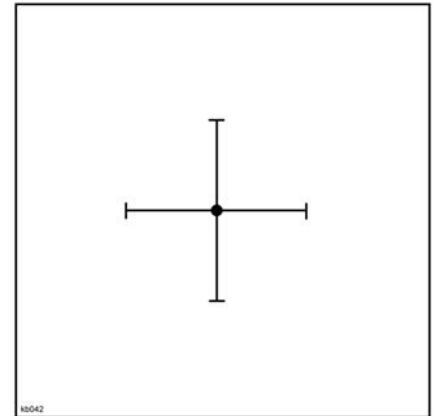

Cutting diagram once the alignment process has been successfully completed.

Y correction — correcting contour error caused by blade clamped at an angle

During Y correction, the cuts are moved until the respective parallel cuts are on one line.

- Start the **1-1-1-4-5 Test cut** function
- Measure distance a (mm/in) of the parallel cuts and calculate as follows:

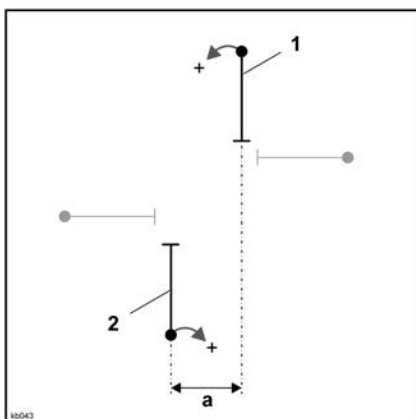

Option 1: Line 1 has to be moved to the left and/or line 2 has to be moved to the right to lie along the same line.

$$Y = \text{existing Y correction value} - a/2$$

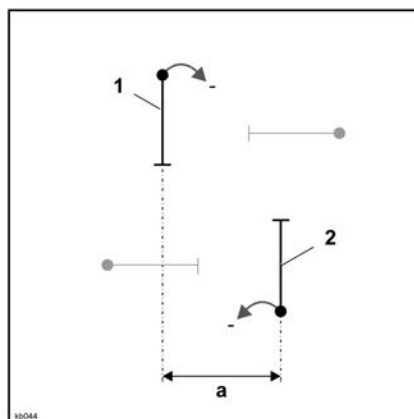

Option 2: Line 1 has to be moved to the right or line 2 has to be moved to the left to lie along the same line.

$$Y = \text{existing Y-correction value} + a/2$$

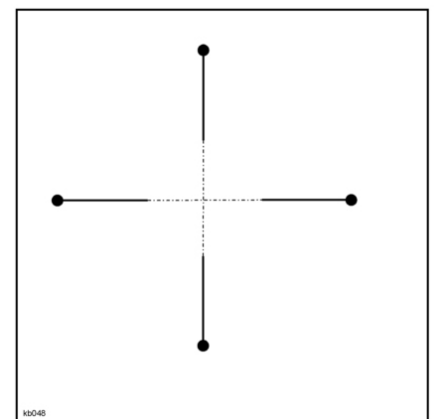

Result: The cuts are along one line.

- Enter the calculated value **Y** in the field **1-1-1-4-3 Correct Y**
- Perform a test cut and recalculate the correction value, if necessary.
- The Y-correction is complete when the cuts are on the same line (tolerance: ± 0.1 mm). Where necessary, check this using a magnifying glass.

X-correction — correcting contour error caused by displaced blade

During the X correction, the cuts are moved until each penetration point is exactly in the center.

- Start the **1-1-1-4-5 Test cut** function
- Measure distance **b** (mm/in) (penetration point line 1 to penetration point line 2) of the opposite cuts and calculate as follows:

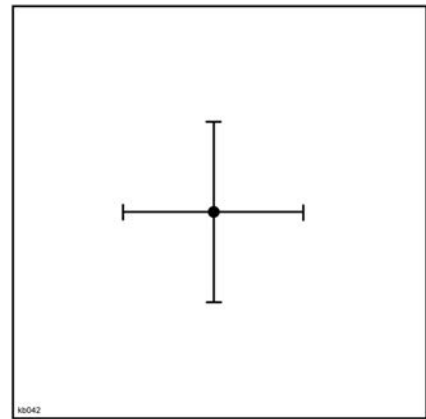
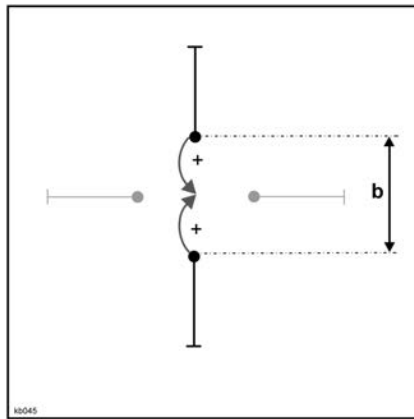
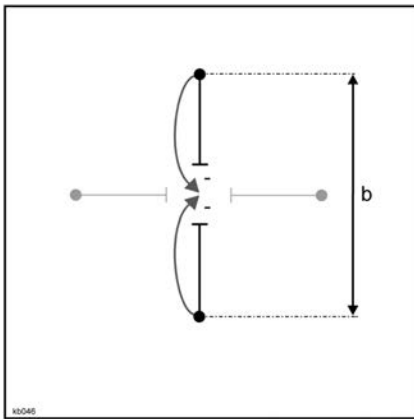

Option 1: The distance between the penetration points is greater than the distance between the ends of the cuts

$$X = \text{existing X correction value} - b/2$$

Option 2: The distance between the penetration points is smaller than the distance between the ends of the cuts

$$X = \text{existing X correction value} + b/2$$

Result: The penetration points are precisely in the center.

- Enter the calculated value **X** in the field **1-1-1-4-2 Correct X**
- Perform a test cut and recalculate the correction value, if necessary.
- The X-correction is complete as soon as each penetration point is precisely in the center (tolerance: ± 0.1 mm). Where necessary, check this using a magnifying glass.

5.5.4 Correcting the overcut

Overcut distance at penetration point

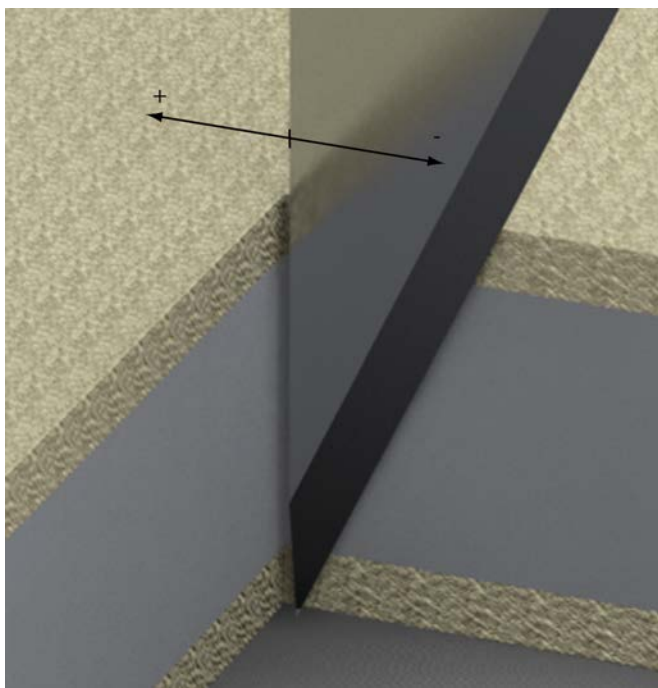

An overcut is usually generated at the penetration point when blades have two cutting edges (e.g. Z11). This can be avoided by using blades with only one cutting edge.

Overcut distance at the end point

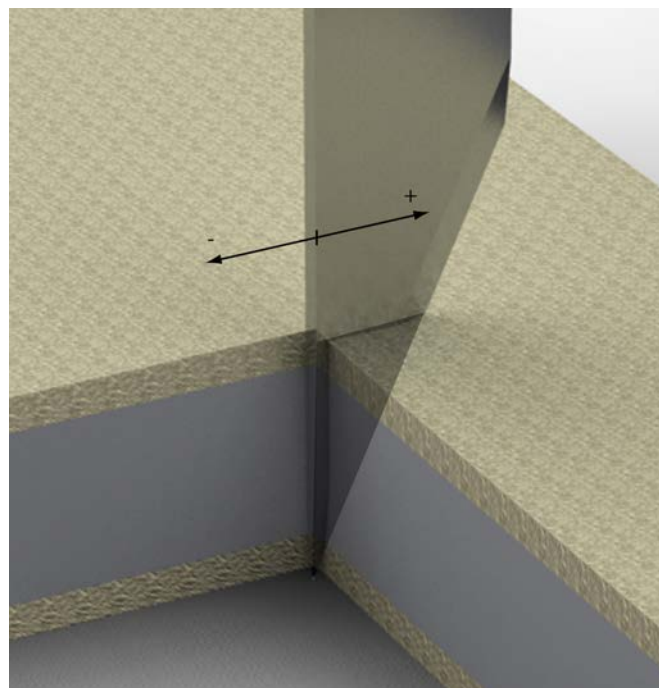

At the tip of the blade, the end point of the straight lines corresponds to the target cutting outline. The shape and dimensions of the blade lead to an overcut on the material top side.

5.5.5 Cutting from 2 sides

Overcut

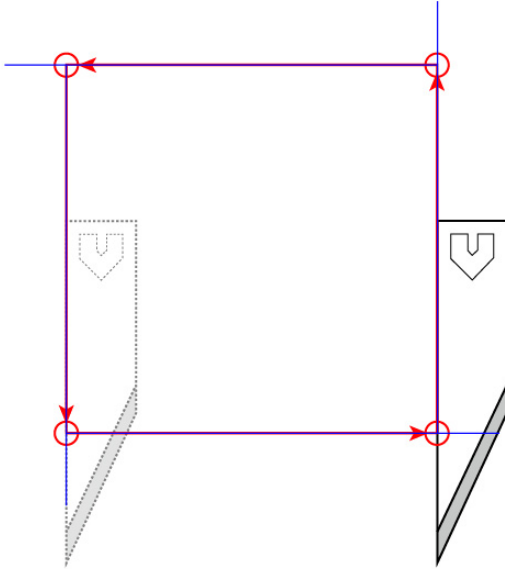

Cutting of corners with overcut.

Optimized

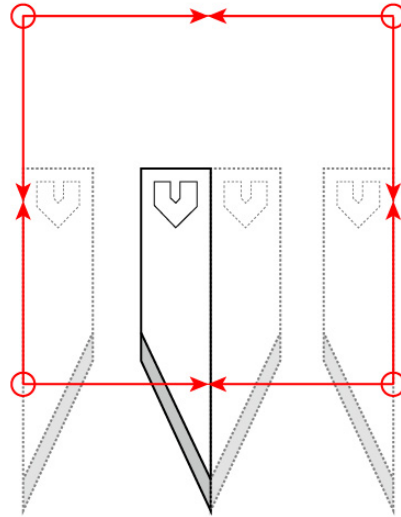

An overcut can be avoided if the cutting path is divided and cutting is carried out from 2 sides. The disadvantage is a longer production time.

5.5.6 Contour error due to overcut on rounded parts

Problem

Underside



The contour cut on the underside of the material corresponds to the desired contour as per the processing file.

Top side



The contour cut on the top side of the material contains the contour error resulting from the overcut.

Schematic representation

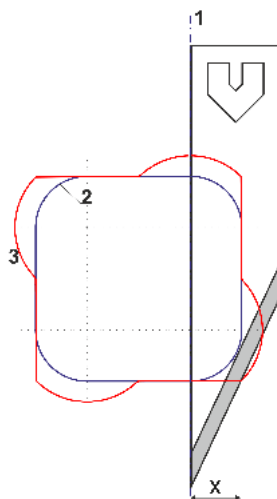

- 1 Rotational axis of the tool
- 2 Desired contour = contour cut on the underside
- 3 Contour cut on the top side with contour error
- X...overcut

Solution

- Use the X-correction to move the rotational axis of the tool and make a compromise between the top side and underside.
- However, moving the rotational axis of the tool will also change the start and end point of the cutting path.
- X correction = $x/2$

Underside

$x = 4 \text{ mm}$, X correction = 2 mm



The contour cut on the underside of the material has a low margin of error

Top side

$x = 4 \text{ mm}$, X correction = 2 mm



The contour cut on the top side of the material has a low margin of error

Schematic representation

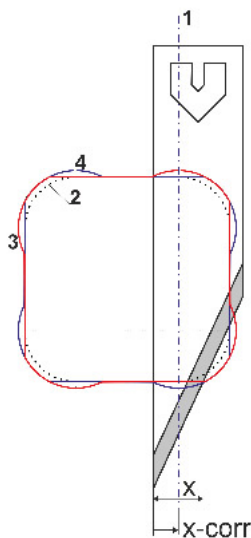

- 1 Rotational axis of the tool offset by the X correction
 - 2 Desired contour
 - 3 Contour cut on the top side with contour error
 - 4 Contour cut on the underside with contour error
- X...overcut

Calculating the overcut

Depending on the cutting depth, the blade geometry will produce a different level of overcut. When undercuts are created, a distinction is made between pre-cut x_1 and post-cut x_2 . The pre-cut x_1 is the distance from the centre of the axis of rotation to the first point where the cutting edge cuts the material surface in the direction of travel. The post-cut x_2 is the measurement from the centre of the axis of rotation to the last point where the cutting edge cuts the material surface. The Z20 pointed oscillating knife and Z11 drag knife are used as examples to illustrate how to calculate the overcut based on the blade you are using and the material you are cutting.

Example Z20

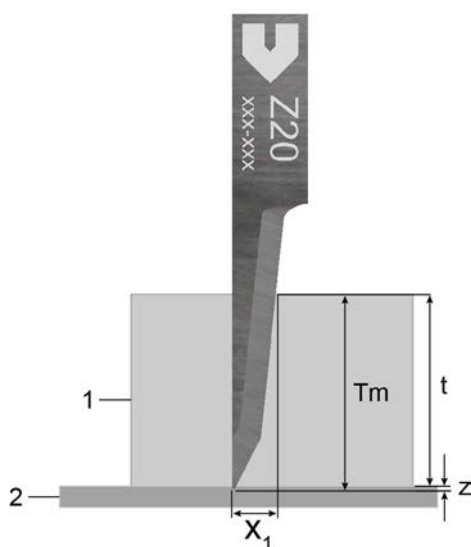

Example Z11

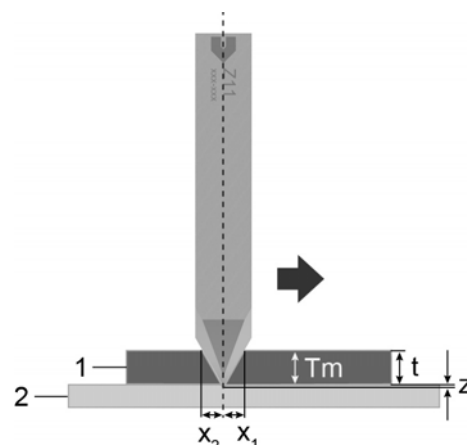

- 1 Material
- 2 Cutting board
- T Material thickness
- Z Set depth
- TM Cutting depth = material thickness t + set depth z
- x_1 Pre-cut
- x_2 Post-cut

The cutting depth TM is made up of the material thickness t and the set depth z. Insert these values into the formula as they are listed in the product description for each blade. The result will be the pre-cut/post-cut in mm.

Sample calculation Z20

Formula $x = 1.2 + 0.11 \times TM$

Cutting depth TM = 10.2 mm

Pre-cut $x_1 = 2,322$ mm

Sample calculation Z11

Formula $x_{1,2} = 0.58 \times TM$

Cutting depth $TM = 5.2 \text{ mm}$

Pre-cut $x_1 = 3,016 \text{ mm}$

Post-cut $x_2 = 3,016 \text{ mm}$

Performing X-correction with X/2

Only perform the X correction with the value X/2 after the XY correction has already been performed once. Open

- **1-1-1-4-2 Correct X.**
- Enter the existing value and the calculated value **X/2** in the field **1-1-1-4-2 Correct X**
- Perform a **1-1-1-4-5 Test cut** and recalculate the correction value, if necessary

5.6 Oscillating cutting



Tip:

Oscillating cutting offer the following advantages:

- The main cutting direction is vertical as opposed to horizontal.
- The horizontal cutting forces are reduced.

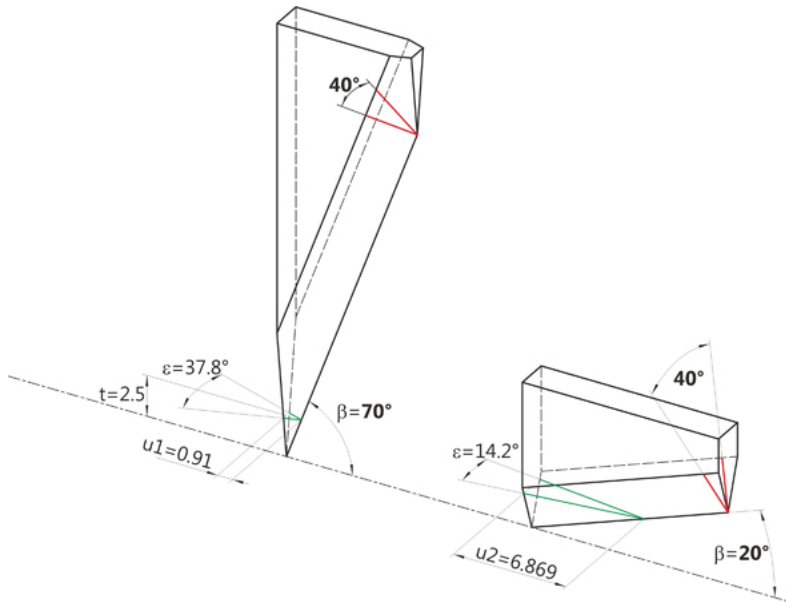

5.6.1 Comparison of EOT/POT specifications

Tool	Stroke A [mm]	Frequency f [Hz]	Stroke speed z_v [m/s]
EOT 0.5	0.5	300	0.471 (sine motion)
EOT 1.0	1.0	300	0.943 (sine motion)
EOT-250	2.5	250	1.963 (sine motion)
POT	8.0*	180	2.880 (sawtooth curve)

* Stroke and frequency decrease with increasing load.



Tip:

Note the following when selecting the tool:

- The higher the frequency, the higher the cutting speed as a function of the perforation of the material.
- The higher the stroke speed, the higher the cutting speed.

5.6.2 Calculation of maximum speed for EOT / POT

Z16

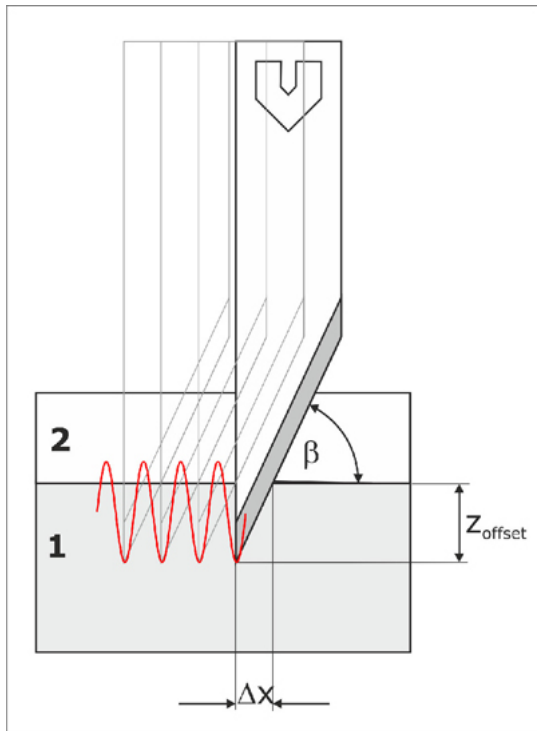

$$v = \Delta X \times f$$

$$v = \frac{Z_{\text{offset}}}{\tan(\beta)} \times f$$

Example:
 $\beta = 55^\circ$
 $f = 300 \text{ Hz}$
 $z_{\text{offset}} = 0.8 \text{ mm}$

$$v = \frac{0.8}{\tan(55^\circ)} \times 300 = 168 \frac{\text{mm}}{\text{s}}$$

Z42

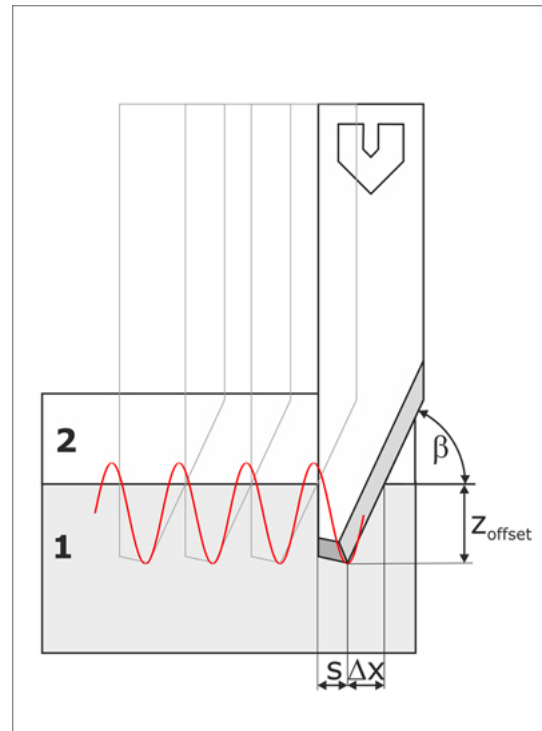

$$v = (\Delta X + s) \times f$$

$$v = \left(\frac{Z_{\text{offset}}}{\tan(\beta)} + s \right) \times f$$

Example:
 $\beta = 55^\circ$
 $f = 300 \text{ Hz}$
 $z_{\text{offset}} = 0.8 \text{ mm}$
 $S = 0.8 \text{ mm}$

$$v = \left(\frac{0.8}{\tan(55^\circ)} + 0.8 \right) \times 300 = 408 \frac{\text{mm}}{\text{s}}$$

5.7 Tips for increasing the rate of production

For high production speeds with good quality, Zünd recommends the following method:

- Set the holding times for the tool (Before Down, After Down, Before Up, After Up) to 0 ms. This is usually necessary for tools with a pneumatic Z-axis.
- To raise the tool, set the maximum values for the speed and acceleration parameters.
- To lower the tool, set the maximum values for acceleration or speed.
- If the material which is to be cut allows it, the default speed of the material feed recommended by Zünd can be increased up to the maximum speed (**1-7-1-3 Speed**).

Option	max. speed [m/s] ¹
Without auxiliary drive	1.0
With auxiliary drive	0.7
Roll-off unit, universal, passive	1.0
Roll-off unit shaft, passive	1.0
Roll-off unit, universal, active	0.25
Roll-off unit shaft, active	1.0
Center winder	0.7
Roll-up unit shaft, active	1.0
Roll-up unit basket, active	0.25
BHS feeder	1.0
BHS stacker	0.5
Synchronization with external material transport	0.7

¹The smallest peripheral device (option) installed on the cutter applies as the maximum value.

5.8 Identifying and rectifying quality problems

Curves cut inaccurately

Acceleration/speed is too high.	Reduce acceleration/speed.	1-1-1-3-2 Speed
Processing data are of poor quality.	Revise the processing data. Send curves to the cutter as arc functions.	-
Wrong blade in relation to material type, material thickness, or cutting contour.	Select a blade which is appropriate to the material, material thickness and cutting contour. For help with selecting the right one, refer to the Zünd accessories catalog.	-

Cutting distortion of curves due to blade overcut

Due to the geometry, the blade produces a large overcut	Select a blade which is appropriate to the material, material thickness and cutting contour. For help with selecting the right one, refer to the Zünd accessories catalog.	-
The overcut correction is not set.	Set the overcut correction. Enter overcut/2 as correction value.	1-1-1-4-2 Correct X

Jerky, stuttering cutter movement

Processing data are of poor quality.	Revise the processing data. Send curves to the cutter as arc functions.	-
The acceleration is too high	Reduce the acceleration	1-1-1-3-3 Acceleration
The vector intermediate angle, for which the speed is reduced to zero if this angle is exceeded, has been set too small.	Check the stop angle (may be too small – enlarge) adjust vectors.	

Material accumulation in corners

The angle from which the tool is raised during change of direction is set too high. As a result the change of direction is performed in the material.	Check setting of lift-up angle (may be too large – reduce)	1-1-1-3-5-1 Auto lift-up angle
---	--	---------------------------------------

Poor quality cutting edges

Wrong tool is used to process the material	Select a different tool. It is often a good idea to use an oscillating tool (EOT or POT).	-
Worn blade	Insert new blade. Ordering information can be found in the Zünd accessories catalog.	-
The processing speed is too fast.	Reduction of the processing speed.	1-1-1-3-2 Speed

Material cover layer is damaged

Wrong tool is used to process the material	Select a different tool. It is often a good idea to use an oscillating tool (EOT or POT).	-
Worn blade	Insert new blade. Ordering information can be found in the Zünd accessories catalog.	-
The processing speed is too fast.	Reduction of the processing speed.	1-1-1-3-2 Speed

Material is perforated.

Wrong blade used in relation to the speed requirement (pointed instead of flat horizontal blade).	Select a blade which is appropriate to the material, material thickness and cutting contour. For help with selecting the right one, refer to the Zünd accessories catalog.	-
The processing speed is too fast.	Reduction of the feed speed.	1-1-1-3-2 Speed

Set depth too low	Set greater set depth	1-1-1-2-7 Z-offset
"continuous path" set incorrectly. Prescribed maximum speed exceeded.	Switch on "continuous path"	1-1-1-3-1-6 Continuous Path

Dimensional stability is wrong

Blade incorrectly clamped.	Check the mechanical blade position.	-
Zoom factor is not "1"	Set zoom factor X to "1"	2-2-1 X scale
	Set zoom factor Y to "1"	2-2-2 Y scale

General quality problems

The processing data sent to the cutter are erroneous.	<p>Prepare the data better in the front end software and send the circle data as an arc function.</p> <p>Define the acceleration and the circle resolution in the cutter quality settings:</p> <ul style="list-style-type: none"> • High: average acceleration, high quality • Normal: average acceleration, average quality • Low: high acceleration, average quality 	1-1-1-3-1-9 Quality
Material hold-down is insufficient.	<ul style="list-style-type: none"> • Set the vacuum range to the material size • Cover open vacuum areas • Increase the vacuum strength (can only be regulated for turbines) • Ensure that the material is even on the working surface • Additionally cover extremely air-permeable materials with vinyl 	1-8 Hold down functions 3-1 Fixing

6 Maintenance

This chapter contains information on the following:

- Safe maintenance of the machine
- Using operating resources
- Maintenance work and maintenance intervals
- Instructions for disposal
- Starting up after periods of standstill

The maintenance list takes into account the cutter (base machine). Maintenance activities for modules, tool inserts and options are found in the respective operating instructions.

Maintenance recommendation

Regular maintenance extends the lifetime of the cutter. Zünd Systemtechnik also recommends an **annual general inspection** of the cutter with follow-up maintenance as needed. Depending on the operating conditions, it may be advisable to reduce the interval.

To enable a swift general inspection, please have the accessory box ready for the service technician.

Decommissioning/extended downtimes and recommissioning

If the cutter is to be shut down or put out of operation for a long period, the modules should be removed from the module carriage and the cutter should be preserved. Please contact your customer service representative to arrange for the preservation of the machine or to put the machine back into operation.

Qualification

Authorized service technician: Personnel authorized by Zünd Systemtechnik, their customer service or contractual partners authorized by Zünd Systemtechnik.

Instructed operating personnel: Personnel of the operator instructed in maintenance by an authorized service technician.

6.1 Safe maintenance of the machine

General safety instructions

- Do not exceed maintenance deadlines.
- Switch the cutter to maintenance mode: switch off and secure against restarting. Also attach a sign to the control panel reading "DO NOT SWITCH ON".
- Only authorized service technicians may carry out service and maintenance work.
- Absolute cleanliness and order must be maintained at the work station at all times.
- Spare parts must meet the technical requirements specified by the manufacturer. Original spare parts are always guaranteed to do so.
- Wearing protective clothing is mandatory for maintenance and cleaning work (see chapter [Safety](#) on page 41, [Personal protective equipment](#) on page 46)
- Keep unauthorized personnel away from the machine during maintenance work.
- Observe the general safety instructions when handling operating materials (hazardous substances, chemicals).



6.2 Tools, operating and auxiliary materials



Tip:

A list of tools, operating and auxiliary materials is provided in the electronics spare parts catalog.

6.2.1 Tools

Description	Task
Allen screwdriver 4 x 170 mm 	For general maintenance work, removal of covers
Padlock	Secure the cutter against restarting during maintenance/cleaning
Lint-free cloth	Oil and clean the guide rails
Container	Drain the maintenance unit condensate water
Cardboard base, drip tray	Oil the Y axis guide rails
Lubricating set 	Oil the X axis guide carriage
Underlay, staple gun with staples (6 mm), industrial scissors, applicator gun, spatula,	Replace the conveyor belt. Only for cutters with material transport with conveyor belt (optional).

Description	Task
marker pen, slotted screwdriver, needle-nosed pliers, cutter blades	
Test piece 	For testing the light curtain (optional)

6.2.2 Operating materials

6.2.2.1 Handling operating materials (hazardous substances, chemicals)

Observe the hazard pictograms as well as the H and P sets (formerly R and S sets) which may be affixed to the packaging of the operating materials (cleaning agents, lubricants and adhesives). Additional information can be found in the respective safety data sheets. The safety data sheets of the operating materials used can be obtained from customer service or the respective manufacturer. Wearing liquid-tight and at least short-term resistant protective gloves and goggles is recommended.



Disposal of operating materials and contaminated aids

Residues of the operating materials, their existing substances as well as all auxiliaries that have been in contact with these substances must be disposed of in an environmentally friendly and proper manner. This applies in particular to lubricants, adhesives and water/oil mixtures (maintenance unit).

- Observe the country-specific rules on environmental protection when disposing of waste materials (hazardous substances, chemicals).
- Collect and store waste material separately in suitable containers and dispose of them only at official sites.
- Allow contaminated items such as cloths and brushes to dry and dispose of them in the same way as the operating materials.

6.2.2.2 Cleaning agents



Note:

The use of incorrect cleaning products, not approved by Zünd, can damage the machine.

- Only use cleaning fluids recommended by Zünd Systemtechnik.
- Do not use abrasive cleaning agents. Caustic substances and scouring agents can damage the surfaces of the cutter (e.g., operating unit).

Cleaning agents	Place of use
Commercial plastic cleaning agent	Covers, metal parts

6.2.2.3 Lubricant

Guide rails, guide bearings, guide carriages

The synthetic lubricant is also used in the food and pharmaceutical industries. It has good water resistance and at the same time serves as corrosion protection.

Name	Specification
Special guide rail oil	Klüber oil [®] 4UH1

Gears

To lubricate the gears, a Teflon special grease for precision gears is used.

Name	Specification
Fin Grease MP 2/3	—

6.2.2.4 Auxiliary materials**Gluing the conveyor belt**

Name	Specification
2-component adhesive (cartridge)	50 ml + mixing jets and spatulas
Masking tape	Roll, 2 cm wide
Gaffer tape	approx. 10 cm

6.3 Maintenance list for trained operating personnel

6.3.1 Special interval

Every 24 operating hours with a router module (RM-A, RM-L, RM-120)

The amount of chips produced during machining depends on several parameters. Therefore, the interval is only a guideline that can be extended or shortened depending on the presence of chips within the beam.

Beam

- [Cleaning the inside of the beam](#) on page 196.

6.3.2 Daily

Safety devices

- Ensure that all EMERGENCY STOP control devices are easy to access and not hidden
-
- Check light barriers on the beam
-
- Check and clean light barrier (optional)
- Clean the cover discs on the columns
 - The columns have not been offset
 - Check function of light curtain on all sides (see [Checking the light curtain](#) on page 85)

Cutter, general

- Visually check the machine for damage
-
- Clean the machine of dust and processing residue
-
- [Clean the chipping protection, brushes](#) on page 194

AKI/ITI tool initialization

- Clean the optical conductor of dust and processing residue (see [ITI, clean light barrier](#) on page 197)

6.3.3 Weekly

Safety devices

- Check function of EMERGENCY STOP control devices

Advance (option)

- Clean rubber pads of the feeder elements
-
- Clean feed guide rail

Compressor (option)

- Check the oil level; top off oil according to specifications, if necessary (carry out maintenance according to the manufacturer's operating manual)

6.3.4 Monthly

Vacuum generator

- [Replacing the vacuum turbine cooling air filter under the cutter](#) on page 199
-

Y axis

- [Clean/oil Y axis guide rails](#) on page 191
-

Module carriage

- [Y axis, oiling the guide bearing and filling the oiler](#) on page 192
-

Maintenance unit

- Drain condensation water (see [Draining the maintenance unit condensate water](#) on page 198)
-

Compressor (option)

- Carry out the maintenance in accordance with the manufacturer's operating instructions

6.3.5 Every six months

X axis

- [Cleaning/oiling the X axis, guide rails/guide carriage](#) on page 189
-

X axis drive, gear version

- Clean and lubricate the gears
-

Y axis drive

- Clean and lubricate the gears
-

Light curtain (optional)

- Check cable for flawless condition
-
- Check plug for tight fit
-

Hose routing (option) with guide rails (gantry size L/XL/2XL/3XL-3200, 2XL/3XL-1600, 3XL-2500 and support rack)

- Clean/oil guide rail with guide carriage (see [Oiling the hose routing](#) on page 193)
-

Vacuum generator

- [Replacing the vacuum turbine cooling air filter next to the cutter](#) on page 200

6.4 Maintenance list for authorized service technicians



Caution:

Personal injury possible

Heavy or sharp-edged components as well as access to live assemblies

- Turn off the cutter at the main switch.
- This work may only be performed by authorized service technicians.

6.4.1 Special intervals

Conveyor replacement

Vacuum plate

- Check leveling and adjust if required
-

Vacuum generator

- Check piping for damage and leaks
-
- Clean filter (turbine only).
-

ITI tool initialization

- Check mechanical adjustment with the adjusting gauge
- Calibrate (menu **1-9-4-1-2 Calibration**)

Every 6 months or every 1000 operating hours

Cutter with carbon fiber protection

- Carry out all work from the section [Additional maintenance on the cutter with carbon fiber protection](#) on page 177

6.4.2 Annually

Safety devices

- Check function of EMERGENCY STOP control devices
-
- Check function of light barriers
-
- Check function of light curtain (optional)
-

Cutter, general

- Randomly check screw connections for tightness at different points. If loose screw connections are found, tighten them and check all screw connections.
-
- Check leveling
-
- Check cabling/wiring and cable run for signs of wear
-

Vacuum plate

- Check evenness and adjust, if required
- Check function of vacuum zone control

Beam

- Check parallelism and adjust, if required
- Check length compensation

Advance

- Check feed system
- Clean rubber pads of the feeder elements
- Clean feed guide rail
- Clean and oil feeder element piston rods

X axis drive, gear version

- Clean chipping protection brushes
- Clean and oil the guide rails/guide carriage
- Check guide carriage for ease of movement, replace if necessary
- Clean drive belts
- Clean drive and guide rollers
- Check drive and deflection rollers for ease of movement, replace if necessary
- Check if tension of the toothed belt / steel belt is correct and readjust, if necessary
- Check if adjustment of the toothed belt / steel belt is correct and readjust, if necessary
- Clean and lubricate the gears
- Check position of the transmission shaft and gear backlash, adjust if necessary
- Check if tension of the motor belt is correct and readjust, if necessary

X axis drive, direct drive

- Clean chipping protection brushes
- Clean and oil the guide rails/guide carriage
- Check guide carriage for ease of movement, replace if necessary
- Clean drive belts
- Clean drive and guide rollers
- Check drive and deflection rollers for ease of movement, replace if necessary
- Check if tension of the toothed belt / steel belt is correct and readjust, if necessary
- Check if adjustment of the toothed belt / steel belt is correct and readjust, if necessary

Y axis drive

- Clean drive belts

Clean drive and guide rollers

Check drive and deflection rollers for ease of movement, replace if necessary

Clean and oil the guide rails

Check if adjustment of the toothed belt / steel belt is correct and readjust, if necessary

Check if tension of the toothed belt / steel belt is correct and readjust, if necessary

Check if tension of the motor belt is correct and readjust, if necessary

Clean and lubricate the gears

Check gear backlash, replace the bearing if necessary

Module carriage

Check guide bearing for ease of movement, if backlash is present adjust the guide bearing until no backlash remains. Replace the guide bearing, if necessary

Oil the guide bearing and fill the oiler

Replace wiper

Vacuum generator

Check function

Clean filter, replace if necessary (turbines only)

Check piping for damage and leaks

Maintenance unit

Drain condensation water

Check pressure settings

ITI tool initialization

Check mechanical adjustment with the adjusting gauge

Calibrate (1-9-4-1-2 Calibration menu)

Hose routing (option) with guide rails (gantry size L/XL/2XL/3XL-3200, 2XL/3XL-1600, 3XL-2500 and support rack)

Clean and oil the guide rails with guide carriage

Compressor (option)

Carry out the maintenance in accordance with the manufacturer's operating instructions

6.4.3 Additional maintenance on the cutter with carbon fiber protection



Tip:

When ordering spare parts, please state that the spare part is intended for a carbon fiber-protected system.



Note:

Damage to electronic components by carbon fibers
Carbon fiber dust and residue from carbon fiber mats are electrically conductive.

- Only use boards that are carbon fiber-protected.
- Before opening a cover that covers a board, thoroughly clean the area.

6.4.3.1 Checking for the presence of the seals and covers

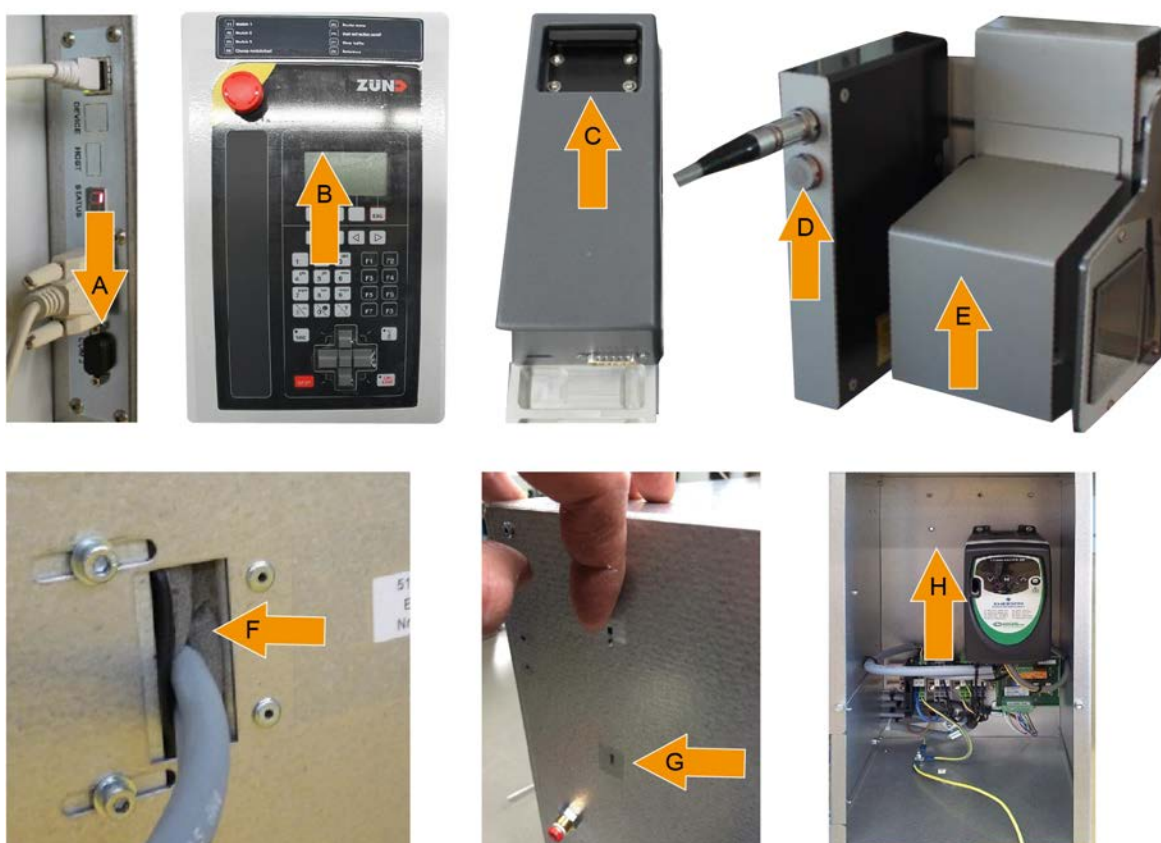

- A** The unused interfaces on the electronics unit and on the frequency converter are covered with caps.
- B** The operating unit is covered with adhesive film.
- C** The inserted modules have a cover plate instead of the filter.
- D** The unused connections on the sensor module (laser pointer) are equipped with a cover cap.

- E The unused module slots are covered with a slot guard.
- F On the electronics unit and power unit, the cable feedthroughs are sealed with foam rubber.
- G The openings on the electronics unit and power unit are taped.
- H The openings on the auxiliary drive box are taped (option).

6.4.3.2 Checking the compressed air hoses

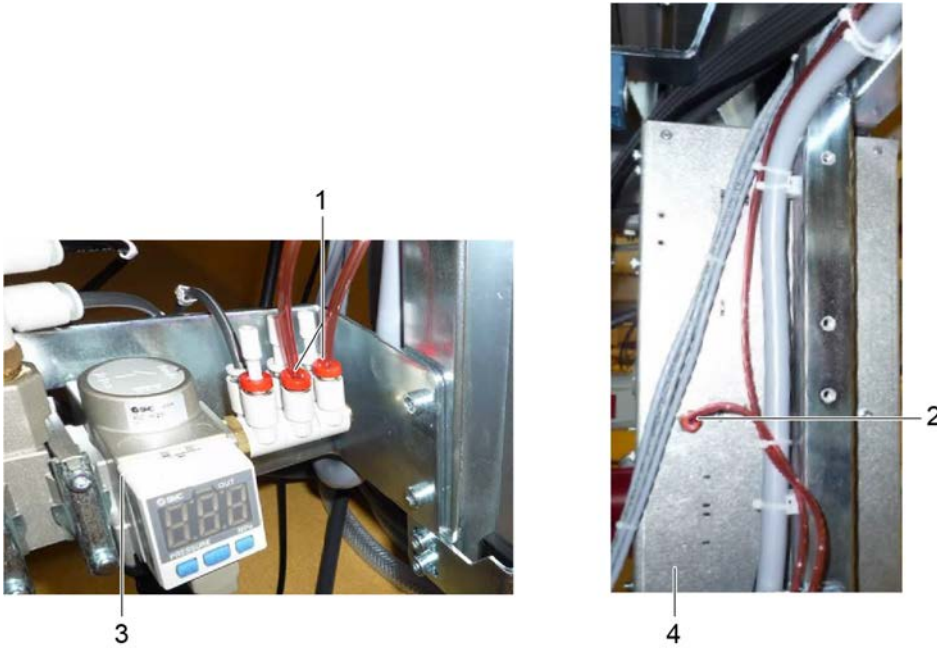

- | | | | |
|---|--|---|----------------------|
| 1 | Maintenance unit plug connection | 3 | Box plug connection |
| 2 | Carbon fiber protection maintenance unit | 4 | Power unit (example) |

- A Check the red compressed air hoses on the carbon fiber protection maintenance unit for tightness.
- B Check the red compressed air hoses on the power unit and electronics unit for tightness.
- C Check the red compressed air hoses on the frequency converter boxes of the optional devices (auxiliary drive, routing module, etc.) for tightness.

6.4.3.3 Setting the sealing air pressure

The sealing air pressure is set on the maintenance unit
Nominal value: **0.45 MPa ±0.01 MPa**



- A Switch on the compressed air supply to the cutter.
- B Set the adjustment wheel on the pressure regulator to the nominal value with the digital display.

6.4.3.4 Testing the sealing air buzzer

The cutter is switched on.



- A Switch off the compressed air.

A warning signal sounds and the color of the digital indicator on the maintenance unit changes to red.

B Turn on the compressed air.

Preconditions

The warning signal stops and the color of the digital indicator changes to green.

6.4.3.5 Adjusting the sealing air throttle valves

The following assemblies have a sealing air throttle valve.

- Power unit
- Electronics unit
- Frequency converter (option)



Note:

Only pressure gauges with the ID number **5207708** may be used:

The pressure gauge has been synchronized with a calibrated pressure gauge.

- The pressure to be set for the sealing air is printed on the top of the pressure gauge.

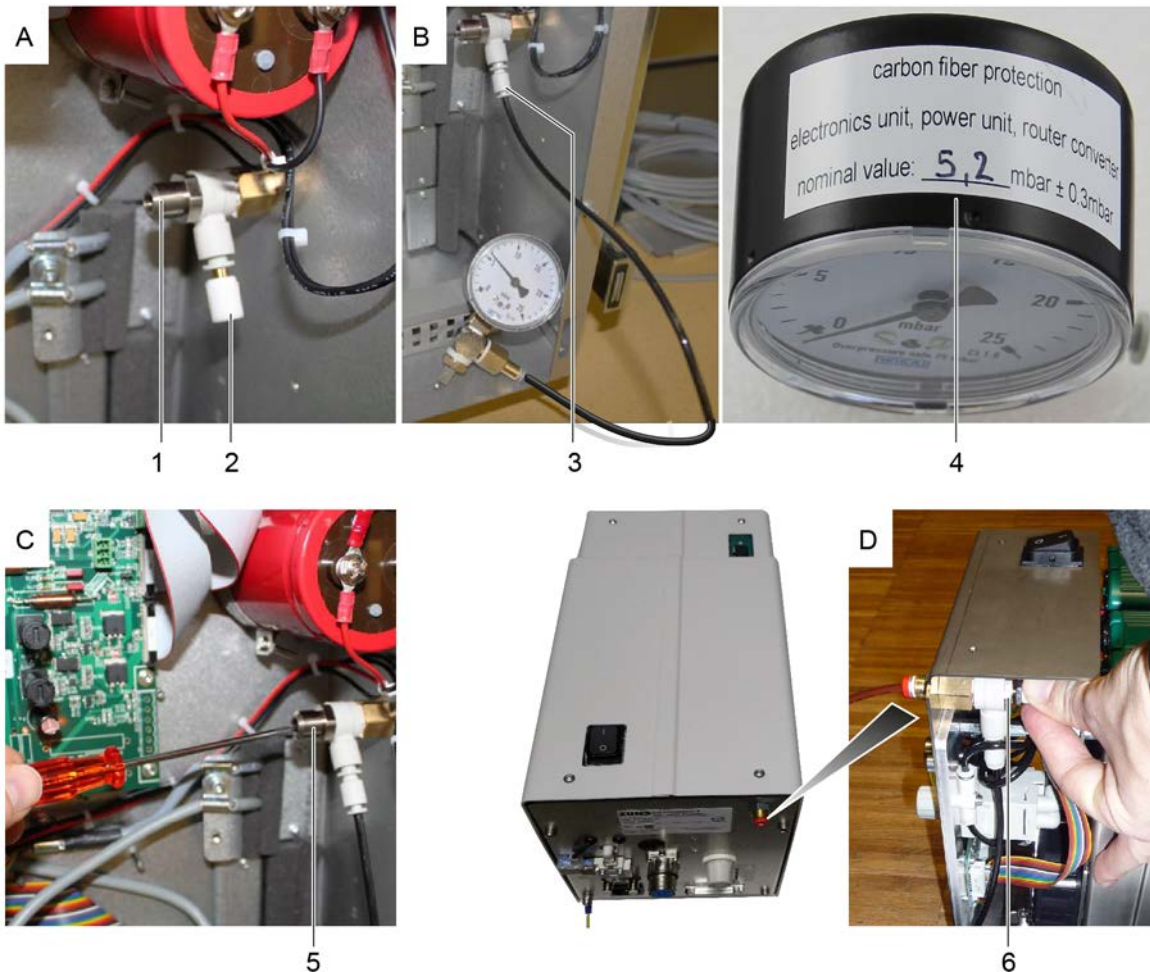

1	Sealing air throttle valve	4	Nominal value on the pressure gauge
2	Silencer	5	Setscrew
3	Connection to throttle valve	6	Lock nut

- A** Unplug the silencer from the sealing air throttle valve.
- B** Plug the pressure gauge into the sealing air throttle valve.
- C** Compare the pressure with the nominal value on the pressure gauge and adjust if necessary:
- | Option | Description |
|------------------|--|
| Electronics unit | Set the pressure using a flat head screwdriver to turn the setscrew. |
| Power unit | |
| Router converter | Loosen the lock nut and adjust the pressure by turning the setscrew. Secure the setscrew using the lock nut. |
- D** Unplug the pressure gauge.
- E** Plug the silencer into the sealing air throttle valve.

6.5 Cutter maintenance mode



Warning:

Risk of injury

The cutter can be mistakenly put into operation during maintenance.

- Always place the cutter into maintenance mode before carrying out maintenance work!

Unless expressly required otherwise, put the machine into maintenance mode before starting maintenance work.

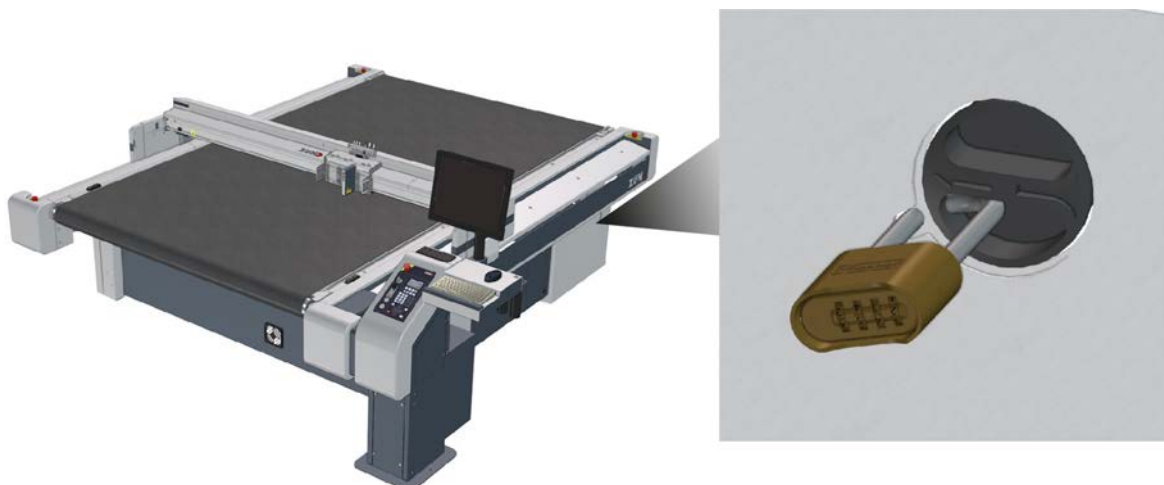

- A** Turn off the machine at the main switch.
- B** Secure the main switch with a padlock.

6.6 Service flaps and covers



Caution:

For safety reasons, all other covers that are not listed here should only be opened for service work by Zünd personnel or personnel authorized by Zünd.

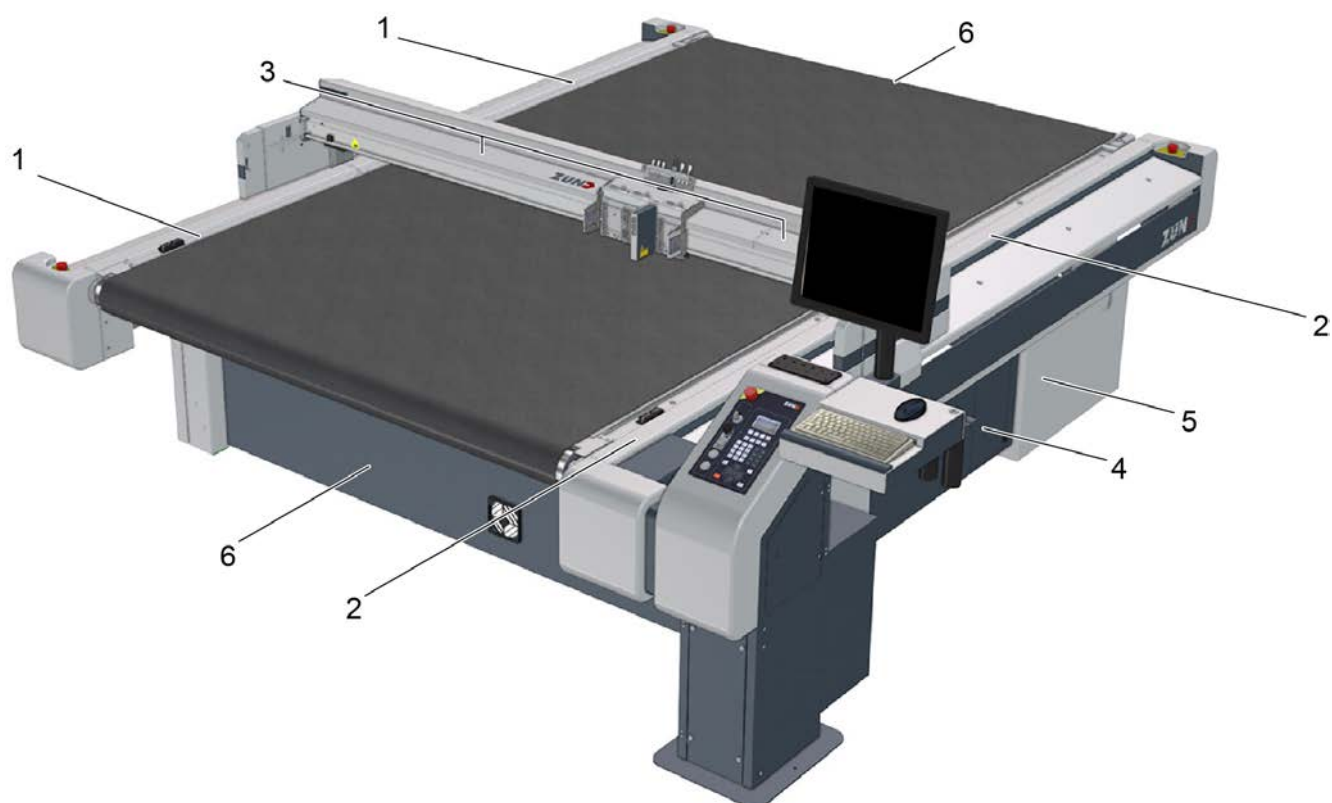

Item	Name	Task
1	Side support cover (A13, A16)	Oiling and cleaning the left guide rails
2	Side support cover (A4, A7)	Oiling and cleaning the right guide rails
3	Beam covering (A1, A3)	Oiling and cleaning the module carriage guide rails
4	Maintenance unit access (A24)	Drain the condensate water, set the pressure
5	Power box cover (A10)	Fuses
6	Front/rear cover (A22, A23)	Changing the conveyor belt, vacuum generator access

6.6.1 Remove the power box cover (A10)

The machine is in the maintenance position.

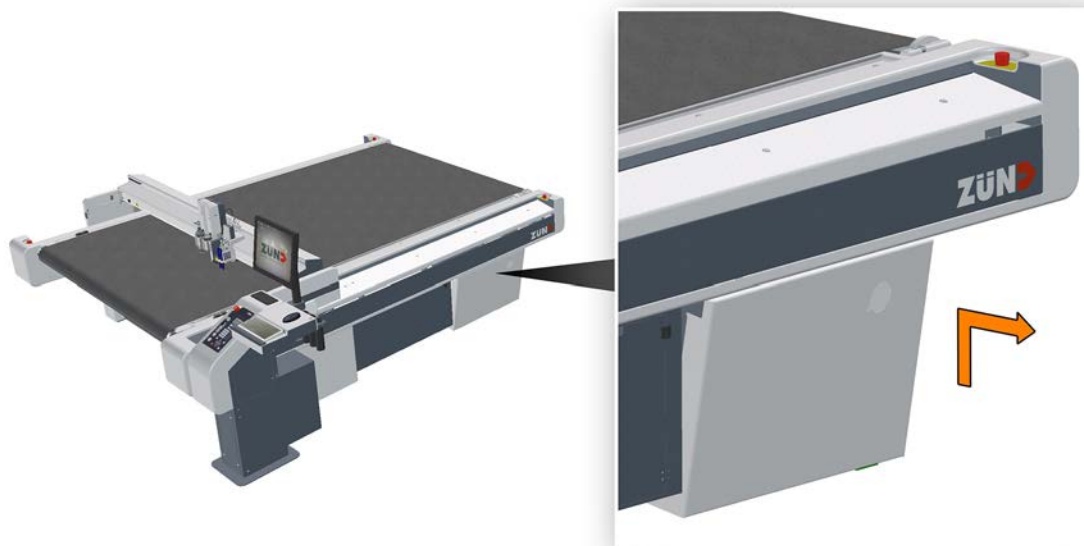

Lift up the cover and tilt it out.

6.6.2 Removing front/rear cover (A22, A23)

The machine is in the maintenance position.

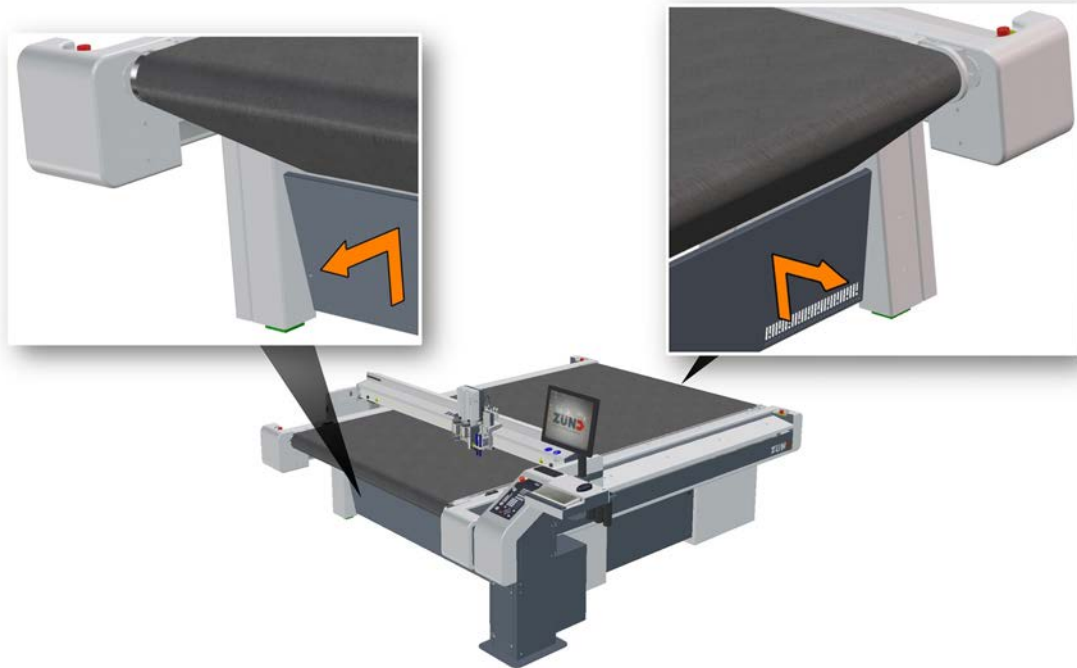

Lift up the cover and tilt it out.

6.6.3 Remove the beam covers (A1, A3)

**Tip:**

The covers are additionally fastened onto the beam with Velcro.

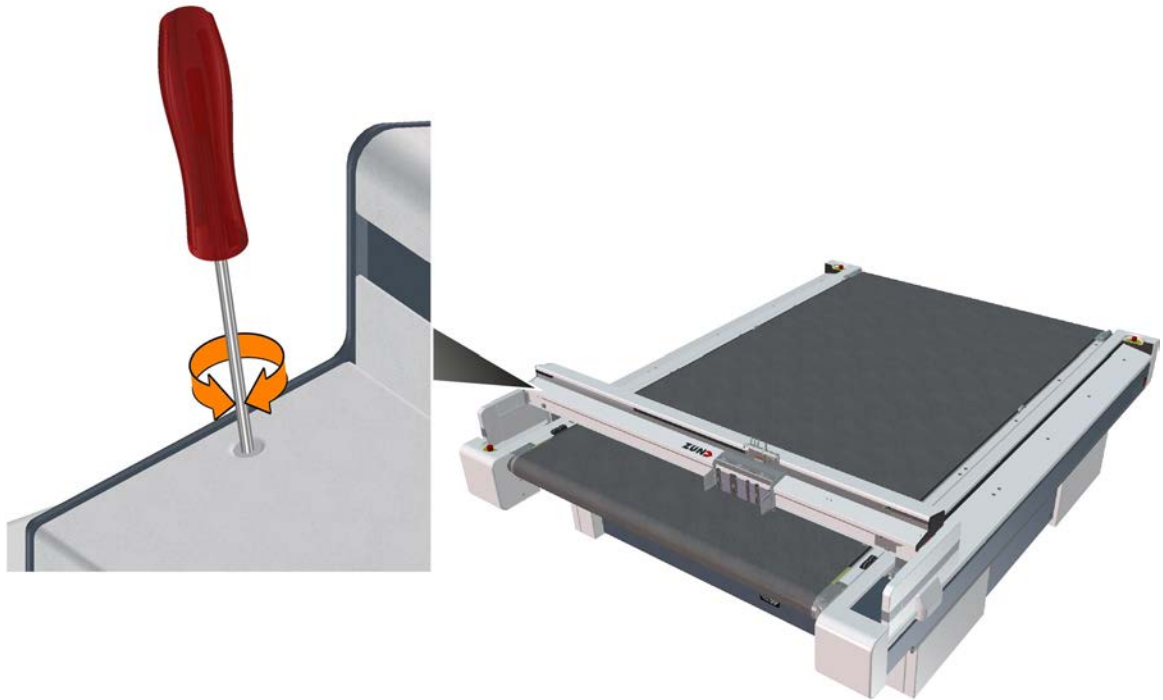

- A** Switch the cutter to maintenance mode.
- B** Manually push the beam forward.
- C** Unscrew the screws at the ends (spanner size 3) and remove with the washers.
- D** Press the module carriage to the right to remove the left cover.
- E** Press the module carriage to the left to remove the right cover.
- F** Remove the cover and place on the working area.

Once the maintenance work is complete, reattach the covers.

6.6.4 Removing the front side support covers (A4, A7, A13 , A16)

The machine is in the maintenance position.

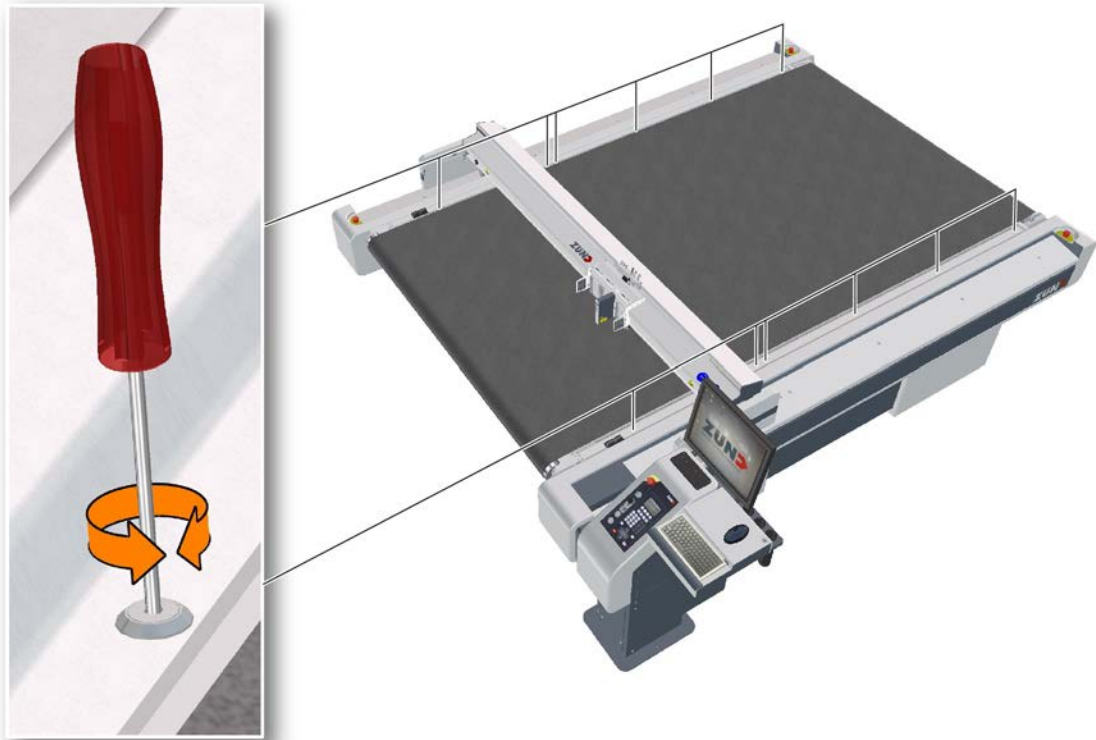

- A Manually push the beam forward.
- B Loosen the safety screws.
- C Remove the rear covers.
- D Manually push the beam backwards.
- E Remove the front covers.

6.7 Visually inspecting the machine for damage



Caution:

There is a risk of injury if the machine is damaged!

Before daily start-up, ensure that there is no damage on the cutter.

- Never start up a damaged cutter or damaged options.
- Have damage repaired immediately by an authorized service technician or trained service personnel.

A Walk around the cutter with present options and check it/them for damage.

B Make sure that all the covers have been fitted. Attach missing covers before switching on.

6.8 Cleaning the machine



Caution:

Risk of injury from sharp tools!

- Remove all modules and tools from the machine before cleaning. For further information, see Danger area during cleaning.



Note:

Do not use compressed air to clean the machine.

Loose cuttings and other dirt will end up in the bearings and drive belts and damage them.



Note:

Danger of damaging the machine!

Incorrect cleaning products and methods will damage the machine.

- Only use gentle cleaning agents and plastic maintenance products for cleaning.
- Never clean the machine using ultrasound, a steam jet, compressed air, etc.

Zünd cutters are production machines that are subject to enormous amounts of stress on a daily basis. Keeping the machine clean will help ensure uninterrupted operation.

Procedure

- Remove all tools and modules from the module carriage (see [Inserting/replacing the module](#) on page 98 as well as detailed descriptions in the instructions of the individual modules/tools).
- Switch the machine to maintenance mode (see [Maintenance](#) on page 167).
- Clean the table plate, operating unit, all covers and panels with a plastic maintenance product at regular intervals (weekly).
- Regularly (daily) remove all material residues from the table, the tools and modules.
- Keep the surrounding area clean (free from material residues, dust).

6.9 EMERGENCY STOP control devices function test



Danger:

Risk of injury due to defective EMERGENCY STOP control devices!

Machines with defective EMERGENCY STOP control devices are not safe for operation. The machine cannot be stopped promptly in hazardous situations.

- Check the function of all EMERGENCY STOP control devices weekly.
- Do not start up a machine with defective EMERGENCY STOP control devices until the problem has been remedied by authorised personnel.

- A** Activate an EMERGENCY STOP control device before starting work or after initialising the machine.
- B** Repeat the process sequentially for all remaining EMERGENCY STOP control devices.

Results

If the machine stops correctly, operational safety is ensured.

6.10 Cleaning/oiling the X axis, guide rails/guide carriage

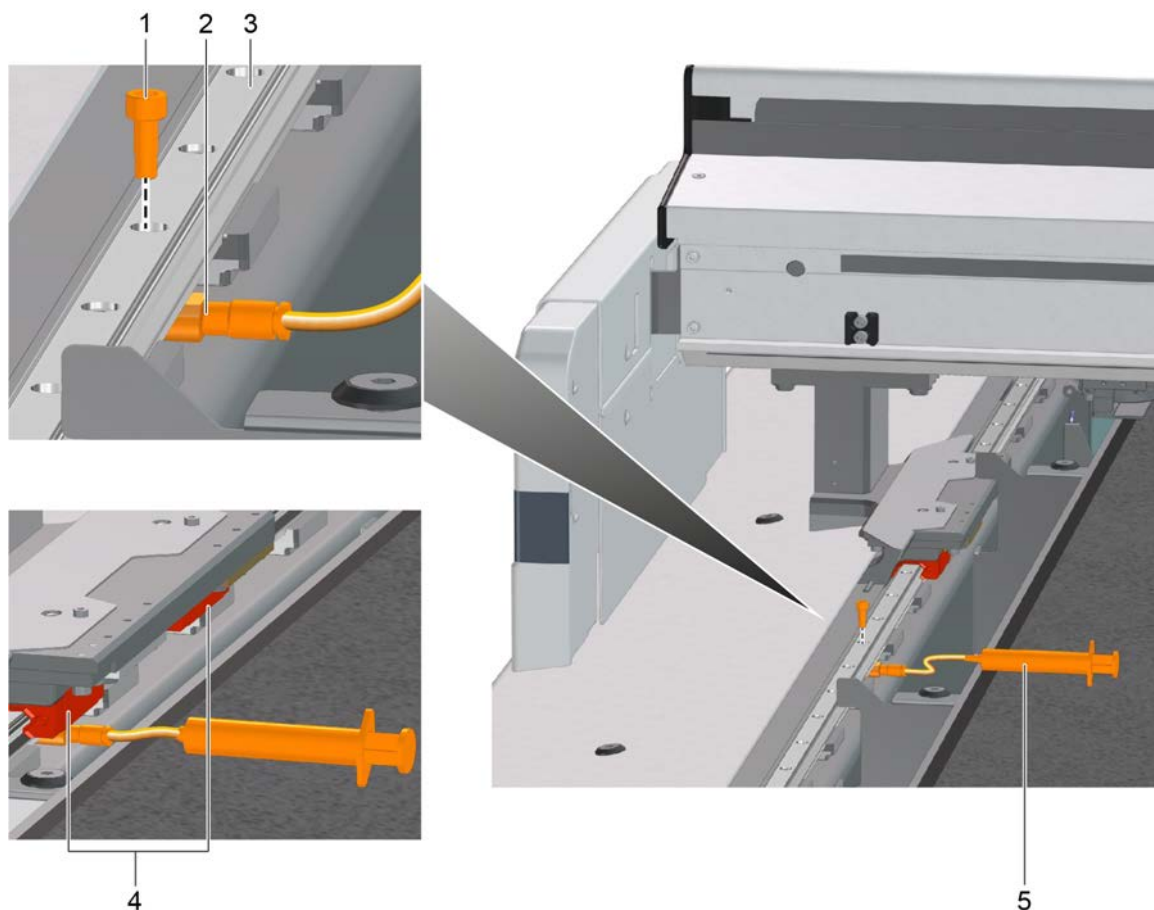

- | | | | |
|---|------------------------|---|-----------------|
| 1 | Hollow screw | 4 | Guide carriage |
| 2 | Lubrication connection | 5 | Lubricating set |
| 3 | Guide rail | | |

- A** Put the cutter into maintenance mode (see [Cutter maintenance mode](#) on page 181).
- B** Remove the side support covers (see [Removing the front side support covers \(A4, A7, A13, A16\)](#)).
- C** Thoroughly clean the entire length of both guide rails using a lint-free cloth.
- D** Push the beam backwards.
- E** Unscrew the hollow screw from the lubrication connection.
- F** Install the lubrication connection of the lubricating set onto the guide rail from below.
- G** Press the syringe until some oil comes out of the hollow screw.
- H** Position the guide carriage above the lubrication connection.

- I** Using the syringe, press approx. 1 ml of special guide rail oil into the guide carriage.
- J** Move the beam forward and backward ten times along the length of the guide carriage above the lubrication connection.
- K** Perform steps G - J for the second guide carriage.
- L** Dismantle the lubricating set.
- M** Clean the area using a lint-free cloth.
- N** Repeat the oiling of the guide carriage on the other side.
- O** Install the covers.

6.11 Clean/oil Y axis guide rails

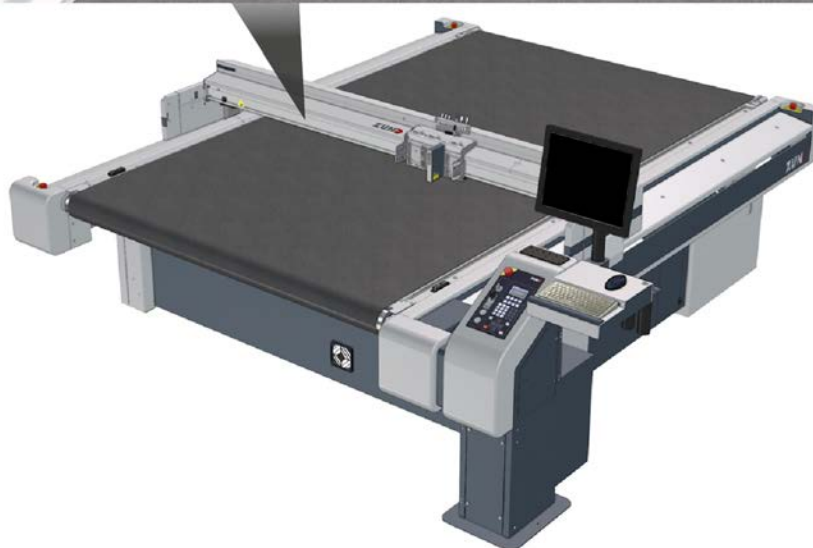
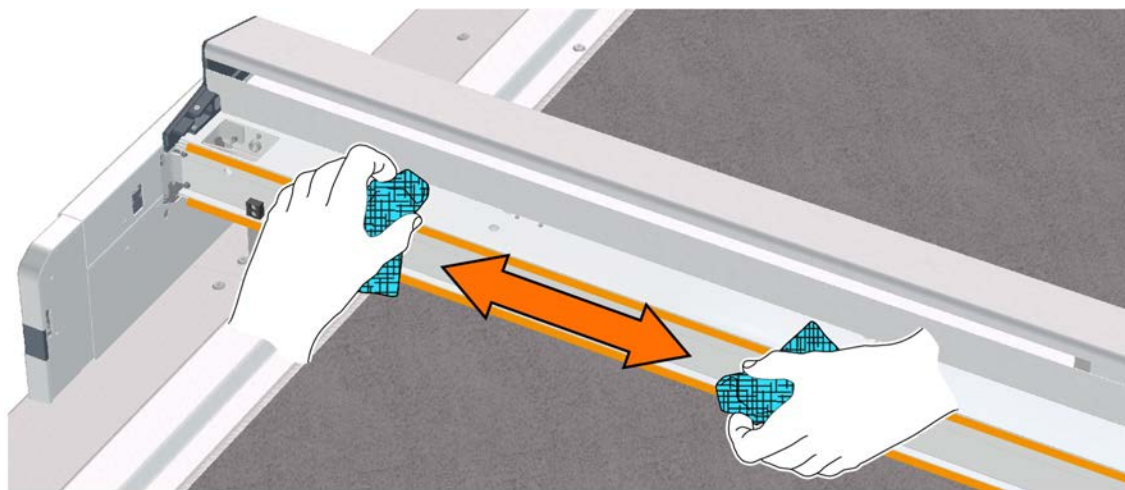

- A** Put the cutter into maintenance mode (see [Cutter maintenance mode](#) on page 181).
- B** Remove the beam covers (see [Remove the beam covers \(A1, A3\)](#) on page 185).
- C** Clean entire length of the guide rails using a lint-free cloth.
- D** Soak a lint-free cloth with special guide rail oil and oil the guide rails.
- E** Install the covers.

6.12 Y axis, oiling the guide bearing and filling the oiler



Tip:

The oil bottle or a syringe with cannula can be used for oiling. Oiling with syringe and cannula is easier.

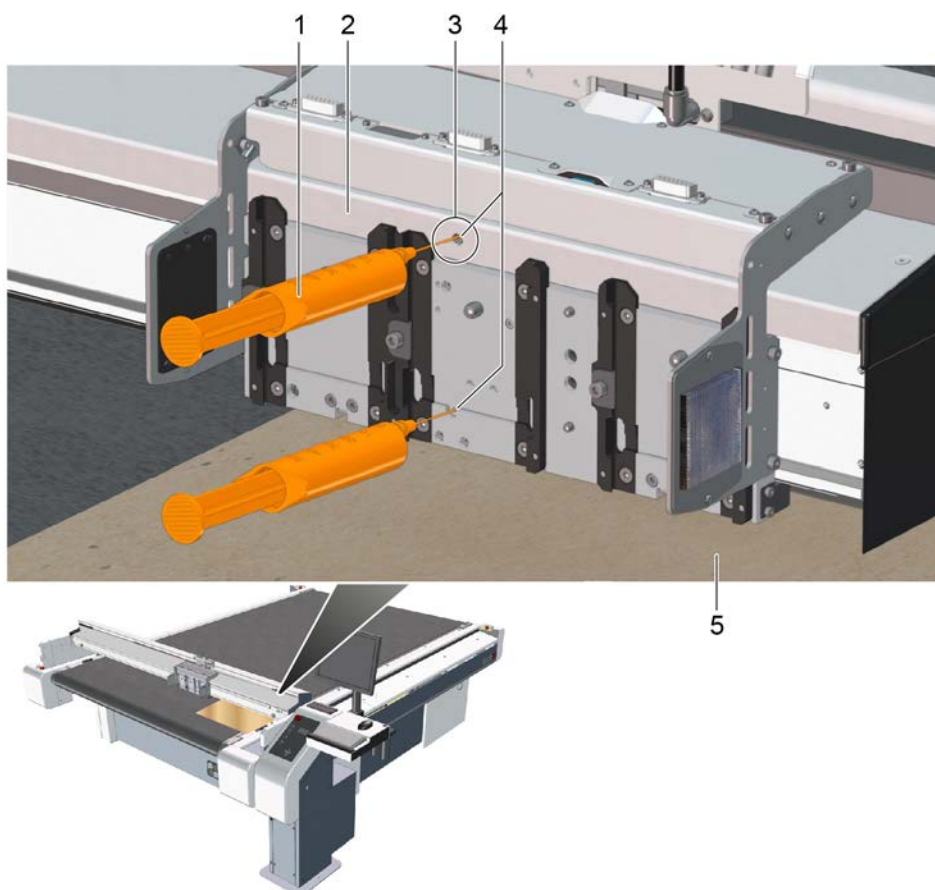

- | | | | |
|---|----------------------------------|---|---------------|
| 1 | Syringe | 4 | Oiling points |
| 2 | Cover | 5 | Underlay |
| 3 | Access to the oiler in the cover | | |

- A** Put the cutter into maintenance mode (see [Cutter maintenance mode](#) on page 181).
- B** Remove all modules from the module carriage (exception: ICC camera or laser pointer sensor module).
- C** Slide the module carriage to the right until the upper oil point is located behind the access in the cover.
- D** Place a cardboard base or drip tray under the module carriage.
- E** Vent the syringe filled with the special guide rail oil.
- F** Insert the cannula of the syringe into the upper oiling point as far as it will go.
- G** Slowly press the syringe until oil comes out.

- H Remove the syringe.
- I Oil the lower oiling point in the same way.
- J Use a lint-free cloth to remove excess oil from the module carriage and the cover.
- K Remove the cardboard base or drip tray.

6.13 Oiling the hose routing

Not every hose routing requires a guide rail. The guide rail is available for support frames and, since August 2017, for gantries sized 2XL/3XL-1600, 3XL-2500, L/XL/2XL/3XL-3200 as well as their ceiling mounting.



- | | | | |
|---|------------------------|---|----------------|
| 1 | Lubrication connection | 4 | Guide carriage |
| 2 | Guide rail | 5 | Syringe |
| 3 | Hollow screw | | |

- A Clean entire length of the guide rails using a lint-free cloth.
- B Unscrew the hollow screw from the lubrication connection.
- C Install the lubrication connection of the lubricating set onto the guide rail from below.
- D Press the syringe until some oil comes out of the hollow screw.
- E Position the guide carriage beneath the lubrication connection.
- F Using the syringe, press approx. 1 ml of special guide rail oil into the guide carriage.
- G Move the guide carriage forwards and backwards ten times over the length of the guide carriage above the lubrication connection.
- H Perform steps D - G for each guide carriage.
- I Clean the area using a lint-free cloth.
- J Dismantle the lubricating set.

6.14 Clean the chipping protection, brushes

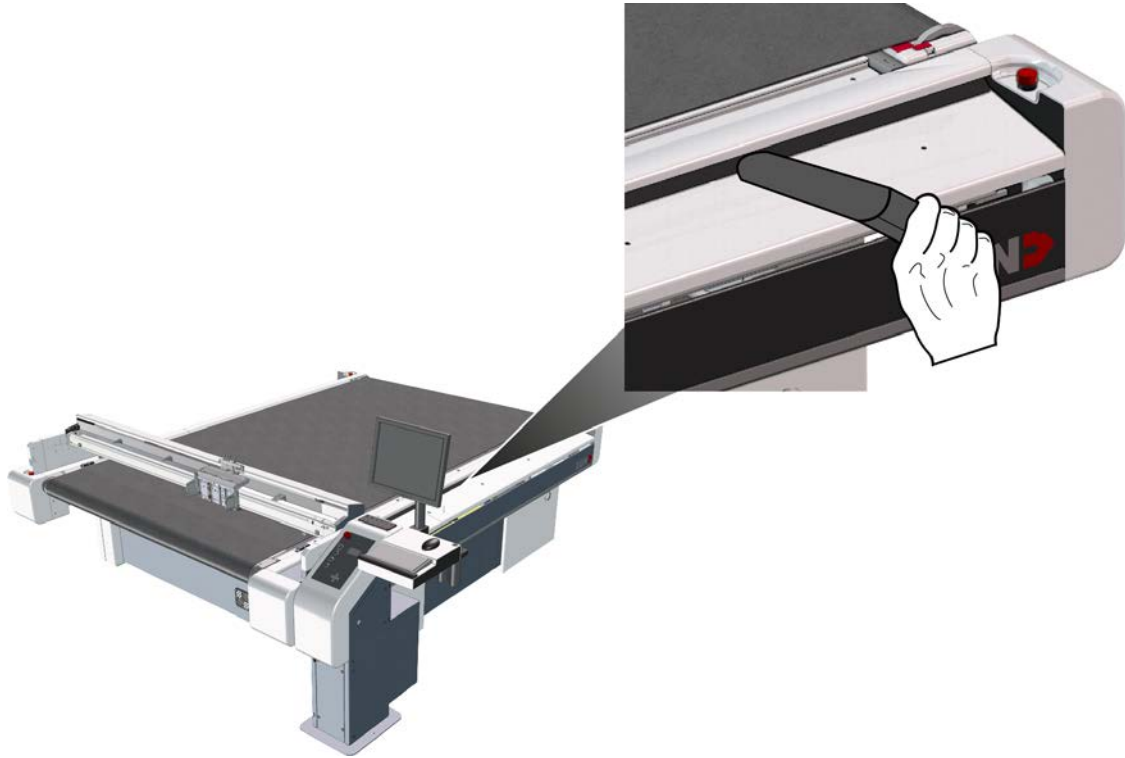

- A** Use a vacuum cleaner to extract chips and dust from the brushes
- B** Move the beam and also clean this area.

6.15 Cleaning transport elements/transport bar

- The machine is in the maintenance position.
- The following tools and materials are ready:
 - Lint-free cloth
 - Alcohol



Warning:

Risk of fire and explosion and risk of chemical burns through the use of alcohol!

Alcohol is highly inflammable and poses a risk to health.

- Keep away from sources of ignition.
- Do NOT inhale the fumes.
- Make sure there is a sufficient supply of fresh air.
- Avoid contact with the skin.
- Wear your personal protective equipment.
- Observe the manufacturer's safety regulations.



Note:

Disposal

Dispose of chemicals and items contaminated with chemicals in accordance with local regulations.

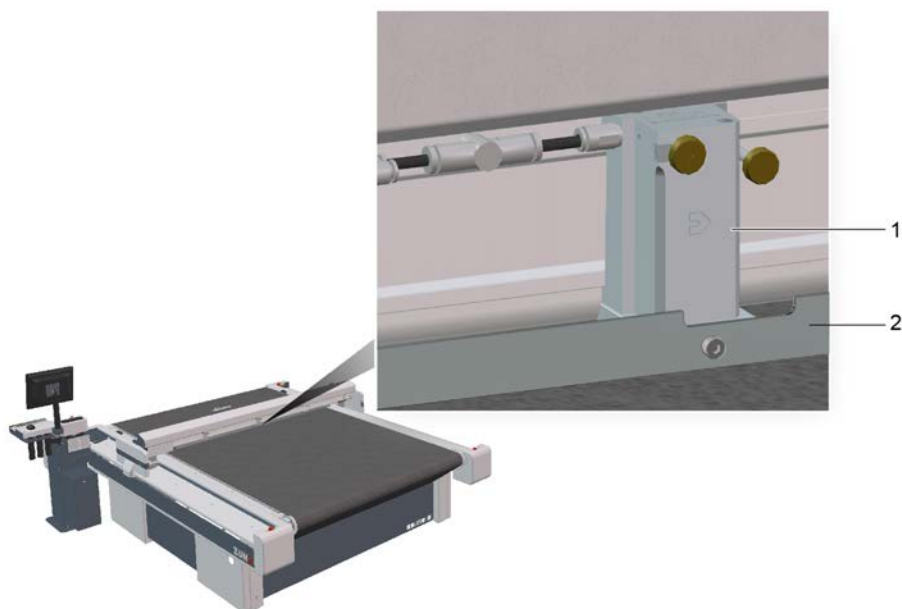

1 Transport element

2 Transport bar

Clean the transport elements/transport bar with a lint-free cloth and alcohol.

6.16 Cleaning the inside of the beam



Note:

Chips can cause damage to the Y drive

- When vacuuming, be careful not to push any chips into the recesses of the guide rollers or holes.

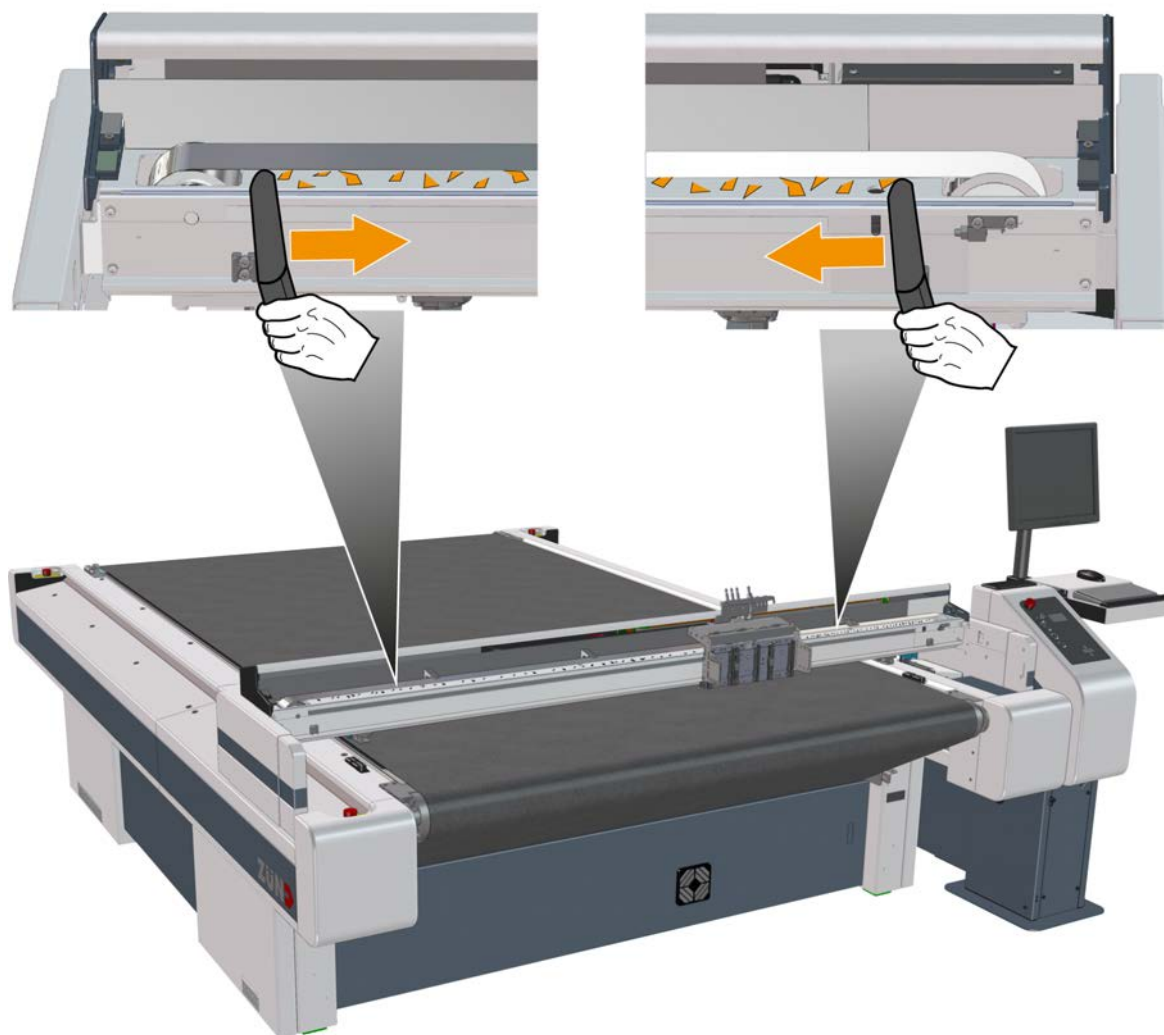

- A Push the bar forwards.
- B Remove the beam covers (see [Remove the beam covers \(A1, A3\)](#) on page 185).
- C Vacuum up the chips from the ends of the beams to the middle.
- D Vacuum the chips out of the hollow spaces.
- E Replace the beam covers.

6.17 ITI, clean light barrier

The machine is in the maintenance position.

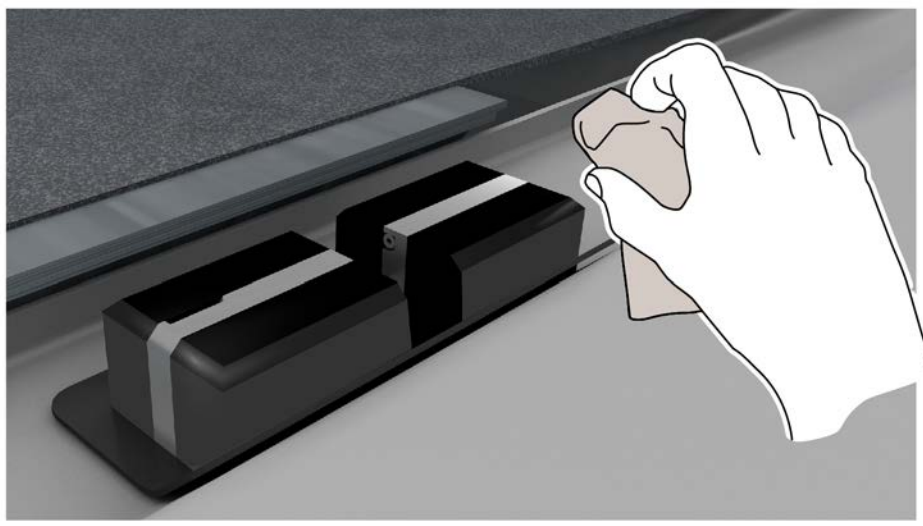

Thoroughly clean the ITI with a lint-free cloth and remove dust and processing residue.

6.18 Draining the maintenance unit condensate water

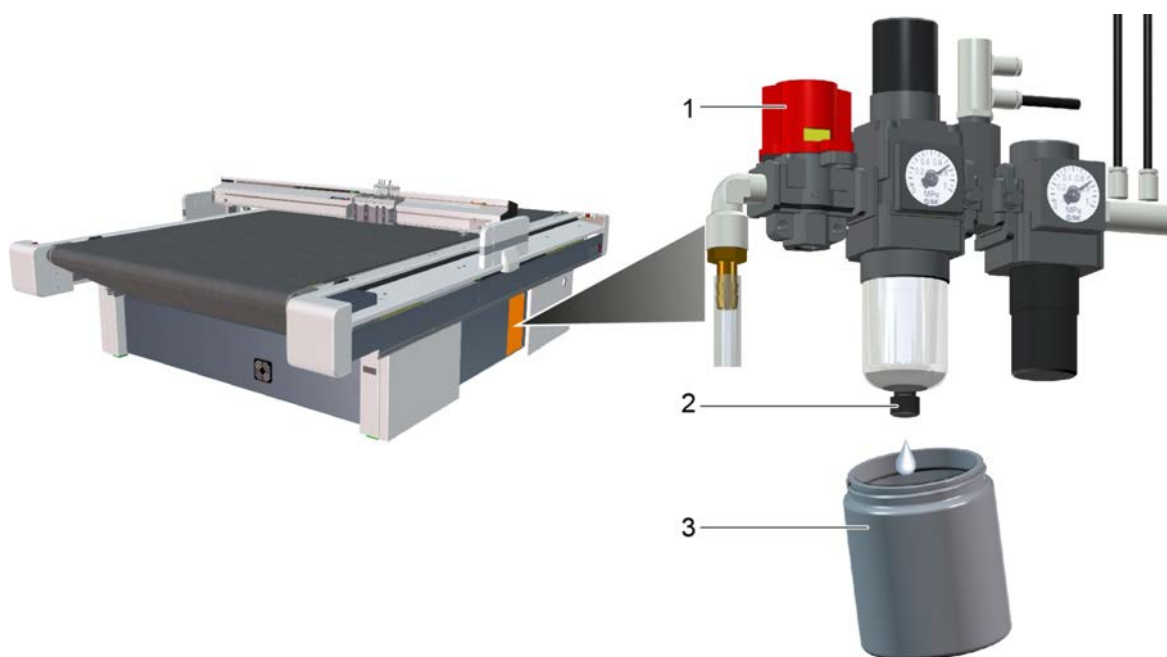

- 1 Stopcock
- 2 Drain screw

- 3 Container



Disposal

The condensate water can become contaminated by oil. Therefore, the condensate water must be disposed of properly according to the specific national regulations.

- A** Open the access point to the maintenance unit (see [Service flaps and covers](#) on page 182).
- B** Set the stopcock on the maintenance unit to "Off".
- C** Hold a container under the drain.
- D** Open the drain screw.
- E** Allow the liquid to drip into the container.
- F** Close the drain screw.
- G** Close the access point to the maintenance unit.
- H** Dispose of the container in an environmentally friendly manner.

6.19 Replacing the vacuum turbine cooling air filter under the cutter

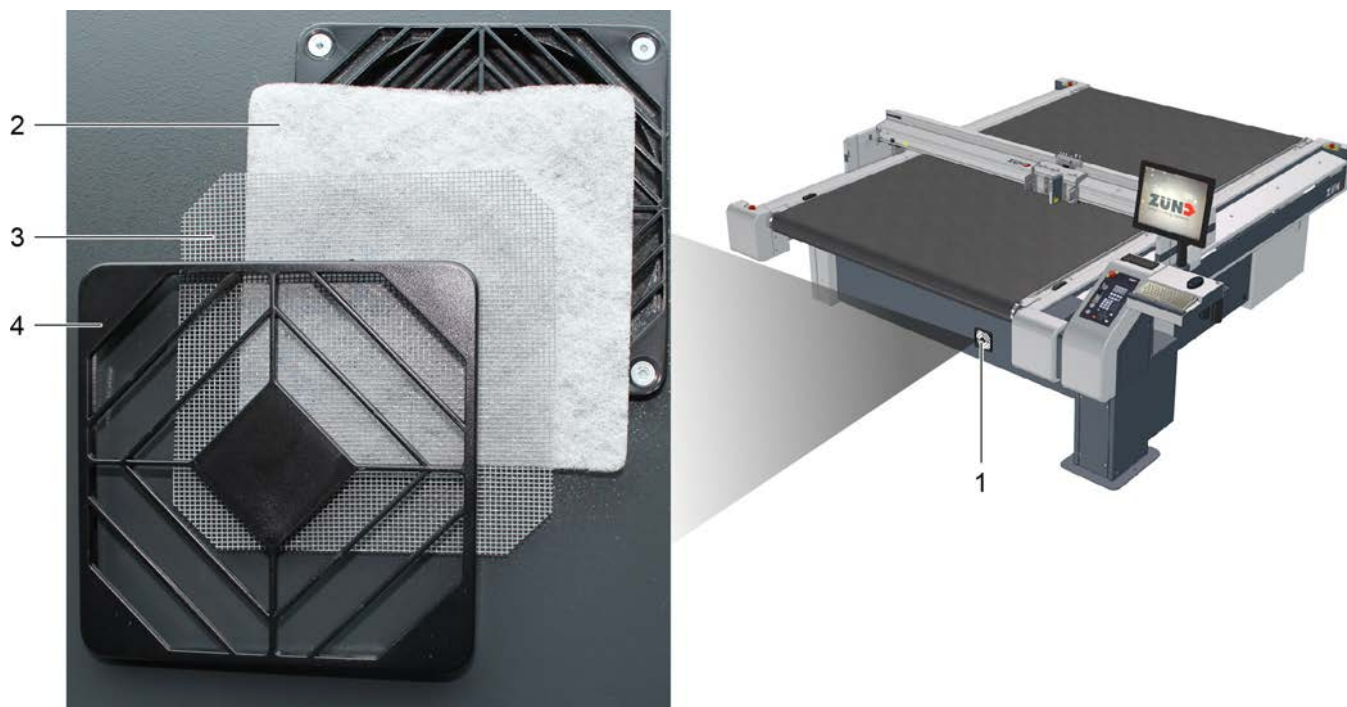

- 1 Position filter
- 2 Filter pad (120 x 120 mm)
- 3 Grid
- 4 Cover

A Remove the cover.

B Insert the new filter pad and grid according to illustration.

C Attach the cover.

6.20 Replacing the vacuum turbine cooling air filter next to the cutter

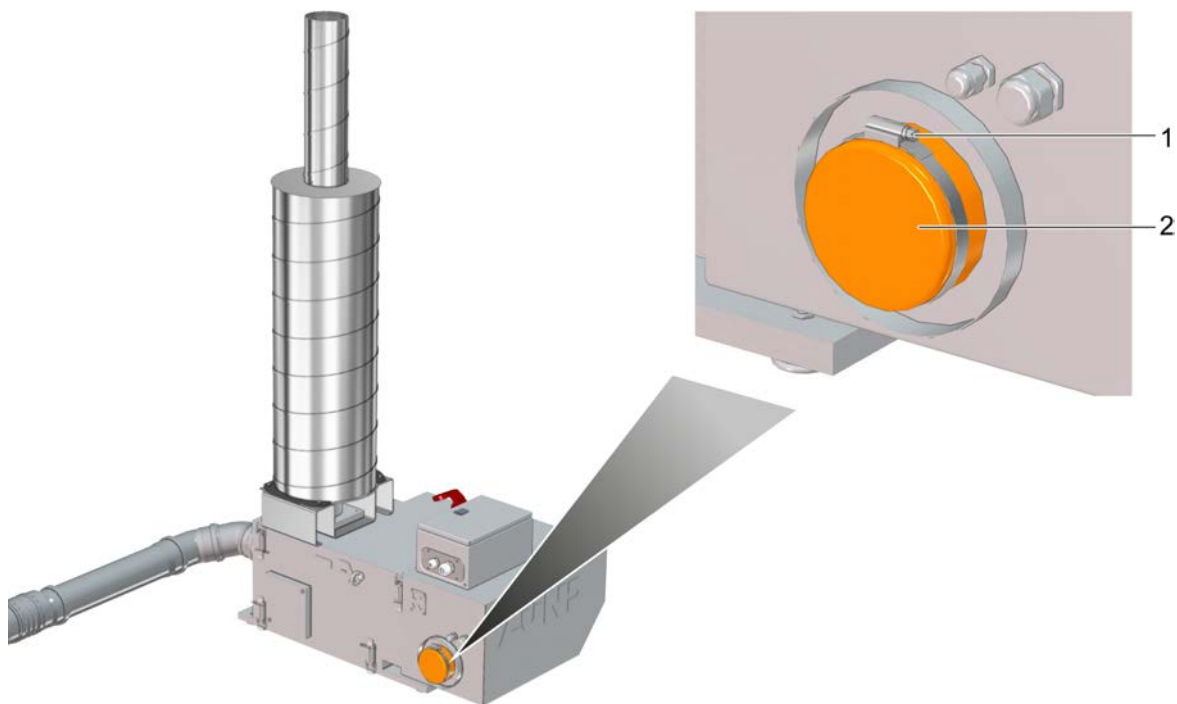

- 1 Hose clip
- 2 Filter pad (185 mm diameter)

- A** Open the hose clip.
- B** Remove and dispose of the filter pad.
- C** Position the new filter pad with the fleece inwards.
- D** Fix the filter pad with the hose clip.

6.21 Resetting 12.5/14.0 kW vacuum pump motor protection relay

The motor protection relay cuts the 12.5/14.0 kW power supply to the vacuum pump under the following circumstances:

- Overload
- Short-circuit
- Phase failure
- Current asymmetry
- Overheating



Note:

Repeatedly triggering the motor protection relay may damage the vacuum pump!
Contact customer service.

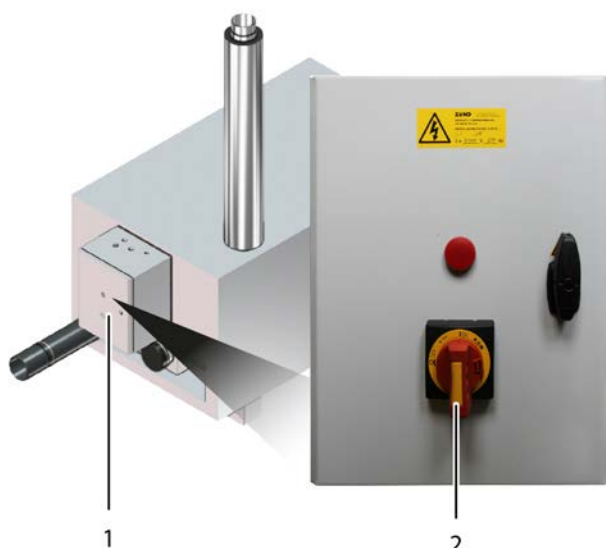

- 1 Switch box
2 Main switch

- A** Check visible connectors of cables from vacuum box switch box for damage. (The vacuum pump has its own power connection.)
- B** If the vacuum pump is overheated, let it cool down first.
- C** At the vacuum pump control box, set the main switch to OFF and then to ON. (See Vacuum Pump Operating Manual, section "Additional Descriptions")
- D** Check the function of the vacuum pump: switch on the vacuum on the cutter (Shift + )

6.22 Reset 2.2/2.55 kW, 4.0/4.6 kW, 5.5/6.3 kW vacuum pump, motor protection relay

The motor protection relay cuts the 2.2/2.55 kW, 4.0/4.6 kW, 5.5/6.3 kW power supply to the vacuum pump under the following circumstances:

- Overload
- Short-circuit
- Phase failure
- Current asymmetry
- Overheating



Note:

Repeatedly triggering the motor protection relay may damage the vacuum pump!
Contact customer service.



- 1 Switch box
- 2 Reset switch

- A** Check visible connectors of cables from vacuum box switch box for damage. (The vacuum pump has its own power connection.)
- B** If the vacuum pump is overheated, let it cool down first.
- C** Press the reset button on the vacuum pump control box (see Vacuum Pump Operating Manual, section "Additional Descriptions").
- D** Check the function of the vacuum pump: switch on the vacuum on the cutter (Shift + .

6.23 ICC camera, cleaning the lens (optional)



Warning:

Risk of fire & explosion and risk of chemical burns through the use of isopropanol

Isopropanol is highly inflammable and poses a risk to health.

- Keep away from sources of ignition.
- Do NOT inhale the fumes.
- Make sure there is a sufficient supply of fresh air.
- Avoid contact with the skin.
- Wear your personal protective equipment.
- Observe the manufacturer's safety regulations.



Note:

Disposal

Dispose of chemicals and items contaminated with chemicals in accordance with local regulations.

A Removing dust and particles

- a) Blow clean using a puffer.
- b) Use an antistatic brush to clean dust that is hard to remove. Do not touch the tip of the brush with the fingers, otherwise the antistatic brush will lose its effect.

B Remove fingerprints or grease.

- a) Blow clean using a puffer.
- b) Wipe clean using a micro-fibre cloth.
- c) For tough grease spots, use a drop of isopropanol on the micro-fibre cloth.

6.24 Starting up after periods of standstill



Note:

Before extended periods of downtime or when starting up your cutter after periods at a standstill, contact the Zünd Customer Service department or your service partner.

Generally, the machine can be started up immediately, even after prolonged periods of standstill. However, some options require running-in routines, which must be heeded in order to ensure continued maintenance-free operation.

6.24.1 Running-in routine 1-9 kW/1-15 kW/1-15 kW plus vacuum turbine

The running-in routine must be carried out after periods of standstill > 6 days.

A Activate all vacuum zones.

B Select **1-8-1-10 Running-in routine** in the menu.

Results

The running-in routine for the vacuum generator starts (duration approx. 8 min). The remaining time will be displayed on the operating unit.

6.25 Instructions for disposal

**Note:**

Contact Zünd customer services or your service partner before you dispose of your cutter.

**Tip:**

Zünd cutters do not contain hazardous substances such as heavy metals, asbestos, batteries, toners, ceramics, radioactive substances or similar. Our cutters are modern industrial devices which correspond to current standards and guidelines for the disposal of old appliances.

- Plastic components > 20 grams are labeled and can therefore be disposed of correctly.
- Steel and plate parts have been varnished with environmentally-friendly varnish or have been powder-coated. Aluminium components have been anodised. They can be disposed of as waste metal.
- PCBs have been soldered with lead-free solder and can be disposed of as electric waste.

You must also observe the following:

- Country-specific legislation and regulations on waste disposal.
- No special measures are generally required when decommissioning the cutter system because no poisonous substances are used.
- Assign a disposal company to remove and recycle the machine correctly.

7 Tools

8 Modules

9 Options

10 Material handling

11 Additional specifications

